

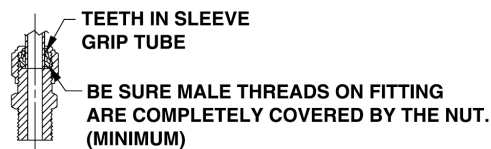

MODEL C GAS HYDRAULIC PUMP

Maximum Capacity: 10,000 PSI
dB(A) at Idle and 700 Bar = 81/96

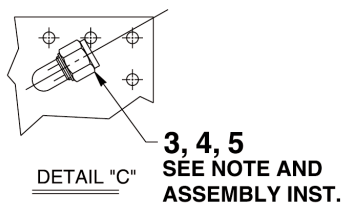
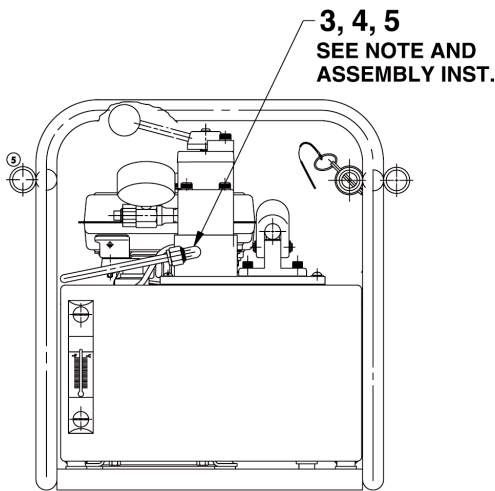
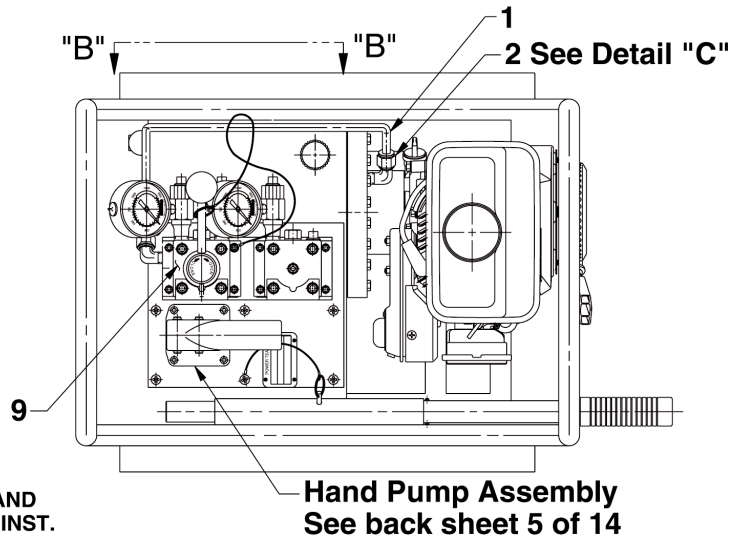
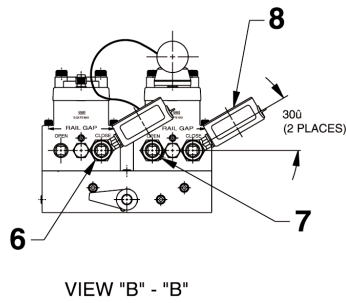

ASSEMBLY INSTRUCTIONS
1. LUBRICATE THE THREADS AND THE
CAMMING AREA OF THE NUT.
NOTE: REMOVE NUT AND FERRULE.
REPLACE WITH STAINLESS STEEL
NUT AND FERRULE.

Note: Graphics changed at last revision(s) made to this form.

Sheet No. 1 of 14

Rev. 9 Date: 09 July 2003

Item No.	Part No.	No. Req'd	Description
1	252150	1	Tube, Oil
2	10665	1	Fitting, Elbow (90 Deg. 1/4 NPTF; See Detail "C")
3	10475	1	Fitting, Elbow (90 Deg. 1/8 NPTF)
4	214270	2	Sleeve, Tube (3/8 Dia.)
5	214269	2	Fitting, Nut Tube (3/8 Tube)
6	9670	3	Fitting, Tee (1/4 x 3/8 x 3/8)
7	10479	1	Fitting, Plug (1/4 NPTF)
8	9040	2	Gauge (10000 P.S.I. 2-1/2" Dia.)
9	421439	1	Valve, Dual (See Sheet 7 of 14)
10	202173CE	2	Decal, Trade Name

PUMP HYDRAULIC SCHEMATIC

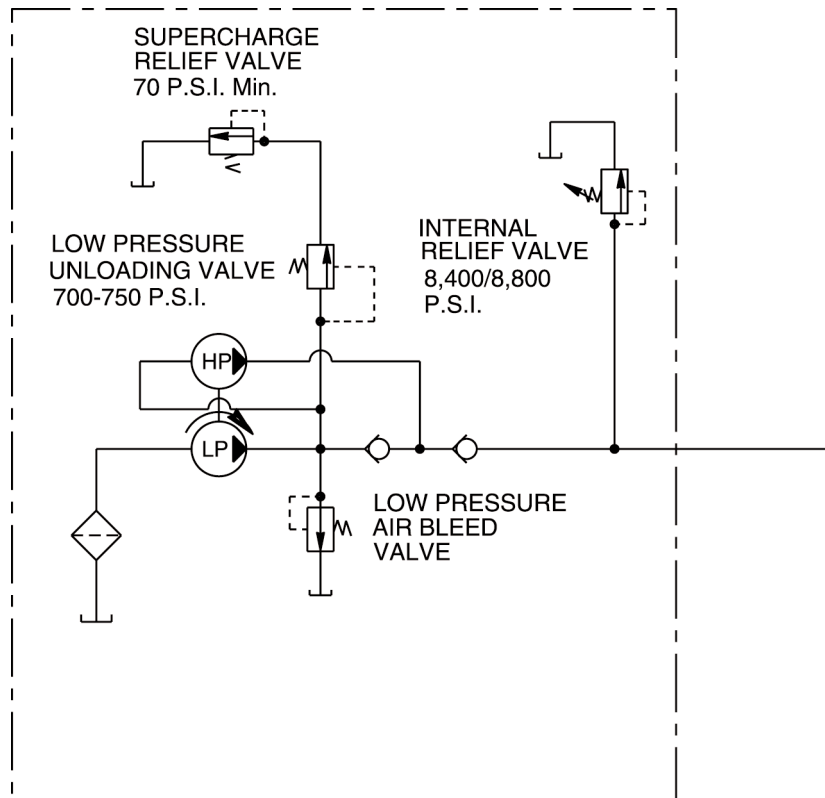

SPECIAL PUMP W/O VALVE

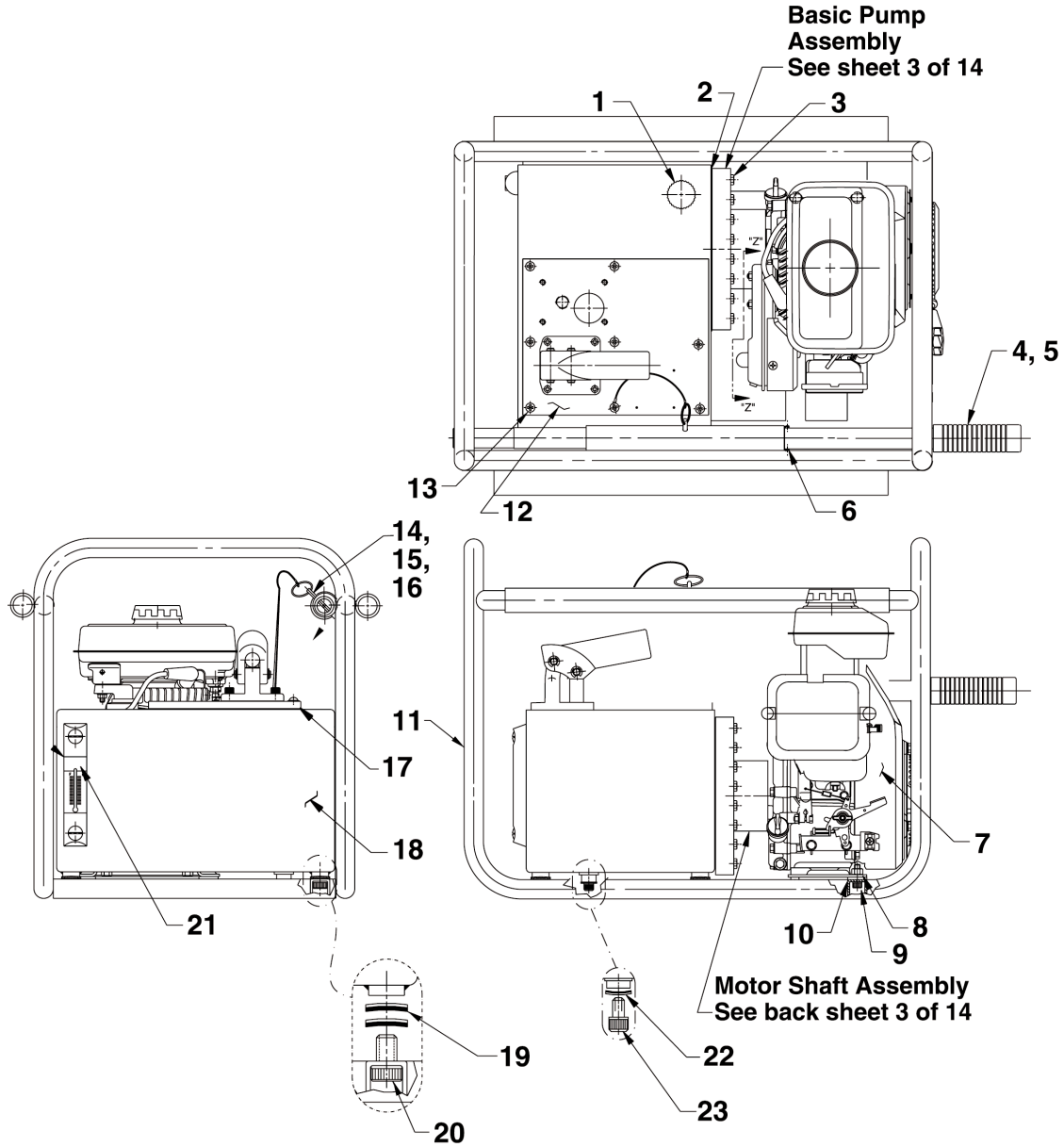

Note: Graphics changed at last revision(s) made to this form.

Parts List and Operating Instructions, Form No. 1000003, Back sheet 2 of 14

Item No.	Part No.	No. Req'd	Description
1	252298	1	Plug, Filler
2	421243	1	Gasket (Note: Apply a bead of silicon gasket sealer on the sealing surfaces at assembly.)
3	10019	28	Cap Screw (1/4-20 UNC X 1-1/4 Lg.; Apply #242 Loctite)
4	351227	1	Handle
5	11390	1	Flex Grip Handle
6	10973	1	Pin (Note: Position pin with equal distance showing on each side of handle.)
7	251506	1	Gas Engine
8	13116	4	Locknut
9	11013	4	Cap Screw (5/16-18 X 1" Lg.)
10	251384	4	Rubber Bushing
11	360195YE3	1	Frame Weldment
12	65152	1	Pump only w/o handle (See back sheet 5 of 14)
13	10177	8	Machine Screw (1/4-20 UNC X 3/4 Lg.)
14	14949	2	Terminal
15	251447	.66 ft.	Aircraft Cable
16	251723	1	Quick Release Pin
17	421260	1	Gasket
18	65151YE3	1	Reservoir
19	252092	8	Rubber Bushing
20	213836	4	Cap Screw (1/2-20 UNF x 3/4 Lg.)
21	350431	1	Fluid/Temperature Gauge
22	19779	1	Seal Washer (Note: Place washer metal side against screw head as shown.)
23	10412	1	Cap Screw (3/8-16 x 1/2 Lg.)
24	19779	1	Seal Washer (Note: Place washer metal side against screw head as shown.)
25	10412	1	Cap Screw (3/8-16 x 1/2 Lg.)

BASIC PUMP ASSEMBLY

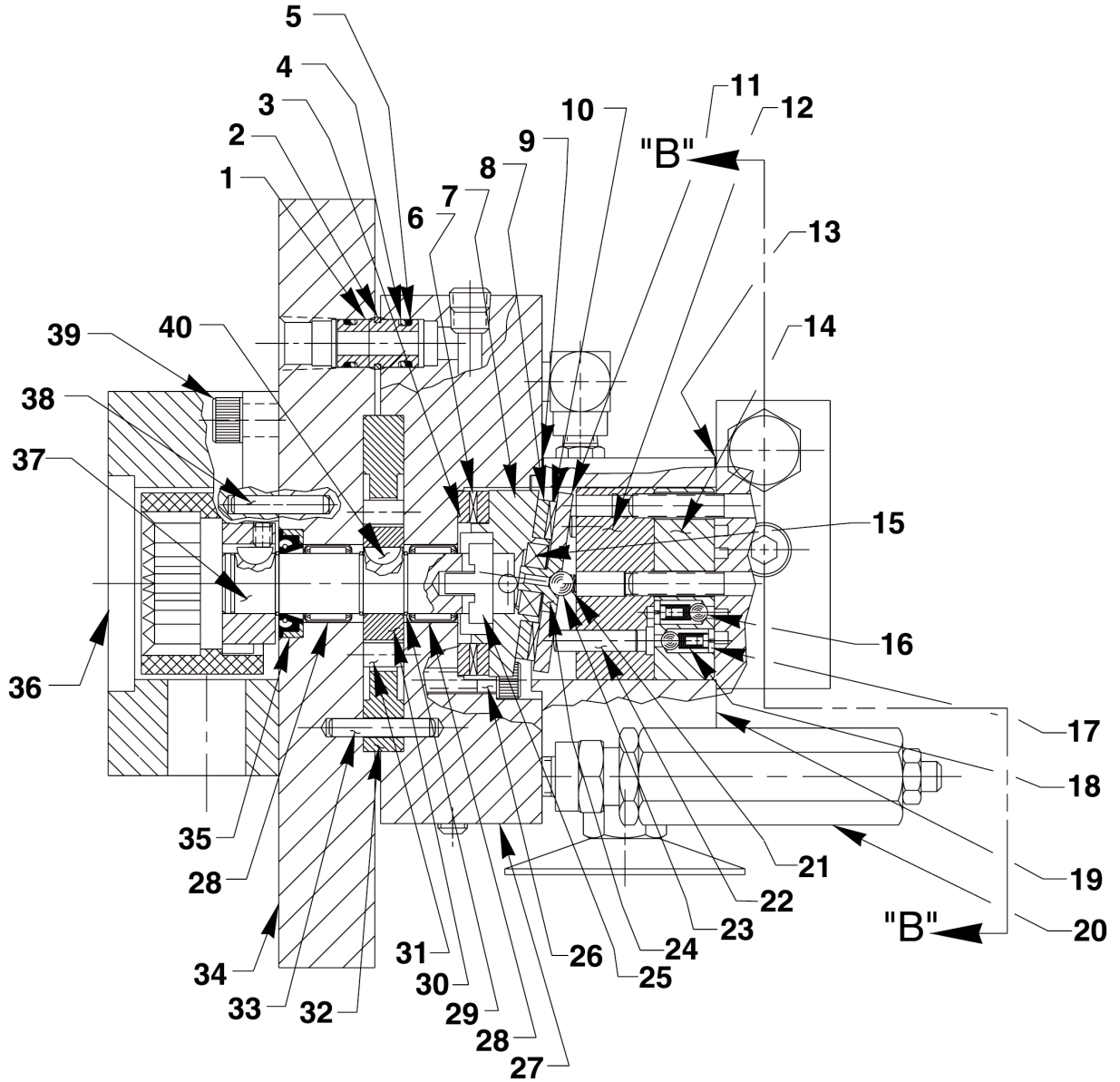

Item No.	Part No.	No. Req'd	Description	Item No.	Part No.	No. Req'd	Description
1	21094	1	Bushing	23	10375	1	Steel Ball (1/4 Dia.)
2	251124	1	Retaining Ring (External)	24	23547	1	Bearing Top Plate
3	11227	2	Bearing Race	25	200397	1	Key
4	*11863	2	Backup Washer (1/2 X 3/8 X 1/16)	26	10854	4	Cap Screw (1/4-20UNC X 1-3/4 Lg.; Torque to 110/120 in. lbs.)
5	*10268	2	O-ring (1/2 X 3/8 X 1/16)	27	58773	1	Pump Body
6	*11228	1	Thrust Bearing	28	12192	2	Needle Bearing
7	350487	1	Angle Plate	29	12178	3	Retaining Ring
8	15432	1	Bearing Race	30	24632	1	Rotor
9	*202691	1	Upper Gasket	31	12193	8	Roller
10	*15431	1	Needle Bearing	32	350500	1	Pump Ring (Adjust for minimum flow.)
11	23548	1	Top Plate	33	211843	1	Dowel Pin
12	41006	1	Barrel	34	65117	1	Cover Plate
13	*202690	1	Lower Gasket	35	*12194	1	Oil Seal
14	41007	1	Valve Head	36	420818-1	1	Engine Mounting Plate (Note: Assemble metal drive gear, outer plastic coupling, and set screw onto pump shaft as specified [see Assembly Instructions] before placing this part. Locate sight hole as shown.)
15	11814	1	Ball Bearing	37	202875	1	Shaft
16	12223	4	Ball (3/16 Dia.)	38	211843	1	Dowel Pin
17	24549	4	Ball Guide	39	10030	4	Cap Screw (5/16-18 UNC X 3/4 Lg.)
18	10445	4	Compression Spring (5/32 O.D. X 3/4 Lg.)	40	12179	1	Woodruff Key
19	350442	1	Spacer				
20	360192-86	1	Relief Valve Assembly (Set at 8,400/8,800 PSI)				
21	10361	1	Compression Spring (1/4 O.D. X 1" Lg.)				
22	20775	2	Piston (7/32 dia.)				

Part numbers marked with an asterisk (*) are contained in Repair Kit No. 301008.

ASSEMBLY INSTRUCTIONS FOR COUPLING 351448

Assemble metal drive gears (with set screws secured with Loctite 222 or equivalent) onto shafts as shown. Place outer plastic coupling as specified.

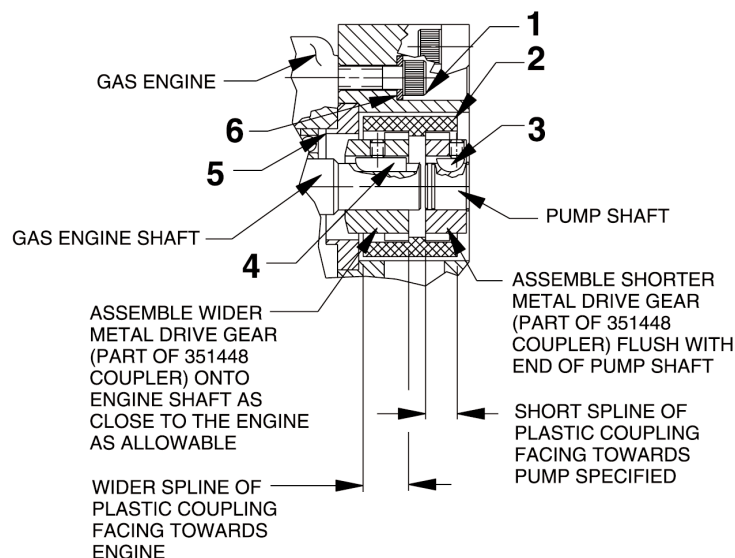

Note: Shaded areas reflect last revision(s) made to this form.

Item No.	Part No.	No. Req'd	Description
1	251502	4	Cap Screw
2	*351448	1	Coupling (Consists of 3 pieces)
3	12179	1	Woodruff Key
4	251235	1	Special Key
5	251473	1	Adapter Pilot
6	10246	4	Lockwasher

* To order the plastic coupling only, order P/N 351448-1.

SECTION B-B

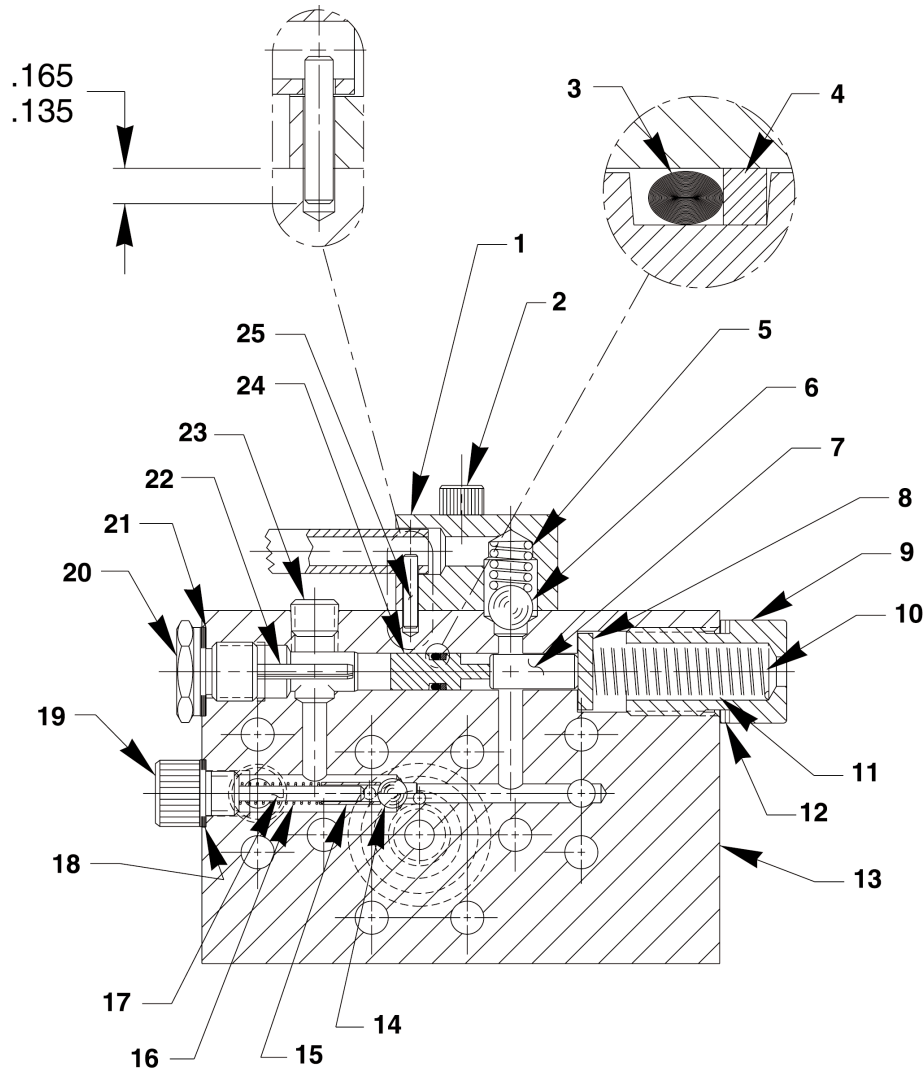

SECTION B-B

Item No.	Part No.	No. Req'd	Description	Item No.	Part No.	No. Req'd	Description
1	350501	1	Valve Body	12	10263	2	Copper Washer
2	10020	1	Cap Screw (1/4-20 UNC X 1-1/4 Lg.)	13	64308	1	End Plate
3	*10265	1	O-ring (5/16 X 3/16 X 1/16)	14	10375	1	Steel Ball (1/4 Dia.)
4	*15174	1	Backup Ring	15	201998	1	Sleeve
5	10362	1	Compression Spring (3/8 O.D. X 3/4 Lg.)	16	14431	1	Compression Spring (3/16 O.D. X 3/4 Lg.)
6	10378	1	Steel Ball (3/8 Dia.)	17	12571	1	Pin
7	250800	1	Dowel Pin (Note: Install with radius end of pin towards piston [Item #23].)	18	*12042	1	Copper Washer (9/16 X 3/8 X 1/32)
8	214692	1	Disk	19	29690	1	Screw (Torque to 175/185 in. lbs.)
9	308430	1	Unloading Valve Fitting	20	250743	1	Ball Stop (Torque to 440/460 in lbs.)
10	16470	1	Compression Spring (19/64 O.D. x 1-3/4 Lg.)	21	*14874	1	Copper Washer (.700 X 1/2 X 1/32)
11	214694	1	Compression Spring (1/2 O.D. X 2-1/8 Lg.)	22	11566	1	Roll Pin
				23	10427	2	Pressure Plug (1/8 NPTF)
				24	250954	1	Piston
				25	11560	1	Pin

Part numbers marked with an asterisk (*) are contained in
Repair Kit No. 301008.

BOTTOM VIEW AND SECTION A-A

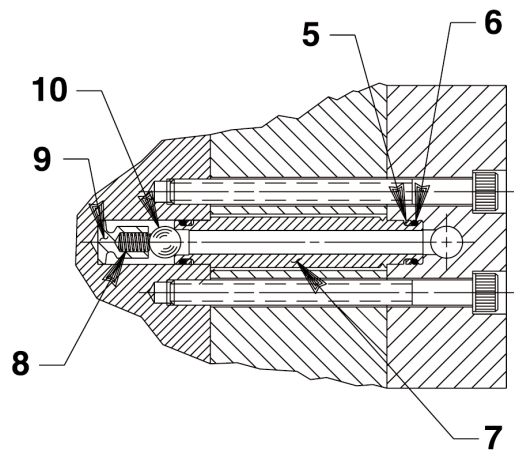
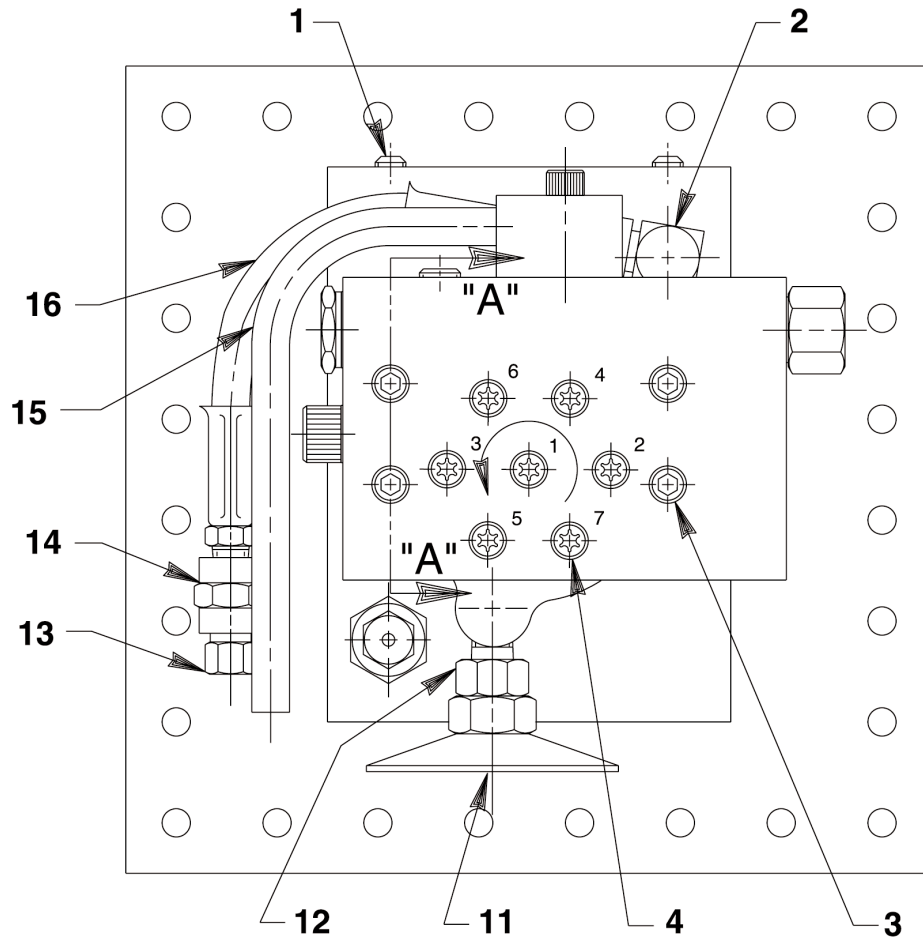

SECTION A-A

Item No.	Part No.	No. Req'd	Description
1	15130	2	Plug (1/16 NPTF)
2	13229	1	Street Elbow
3	11956	4	Cap Screw (1/4-20 UNC X 3" Lg.; Torque to 110/120 in. lbs.)
4	16747	7	Screw (1/4-28 UNF X 1-3/4 Lg.; Lubricate under head and on threads. Torque to 165/175 in. lbs. Torque in sequence shown.)
5	*15085	2	Backup Washer
6	*10267	2	O-ring (7/16 X 5/16 X 1/16)
7	202688	1	Tube
8	15141	1	Spring (3/16 O.D. X 5/8 Lg.)
9	202681	1	Ball Stop
10	10377	1	Steel Ball (5/16 Dia.)
11	29682	1	Strainer
12	250801	1	Intake Tube
13	306957	1	Air Bleed Valve
14	18841	1	Pipe Connector
15	350444	1	Drain Tube
16	350842	1	Hydraulic Hose

Part numbers marked with an asterisk (*) are contained in Repair Kit No. 301008.

HYDRAULIC HAND PUMP W/O HANDLE

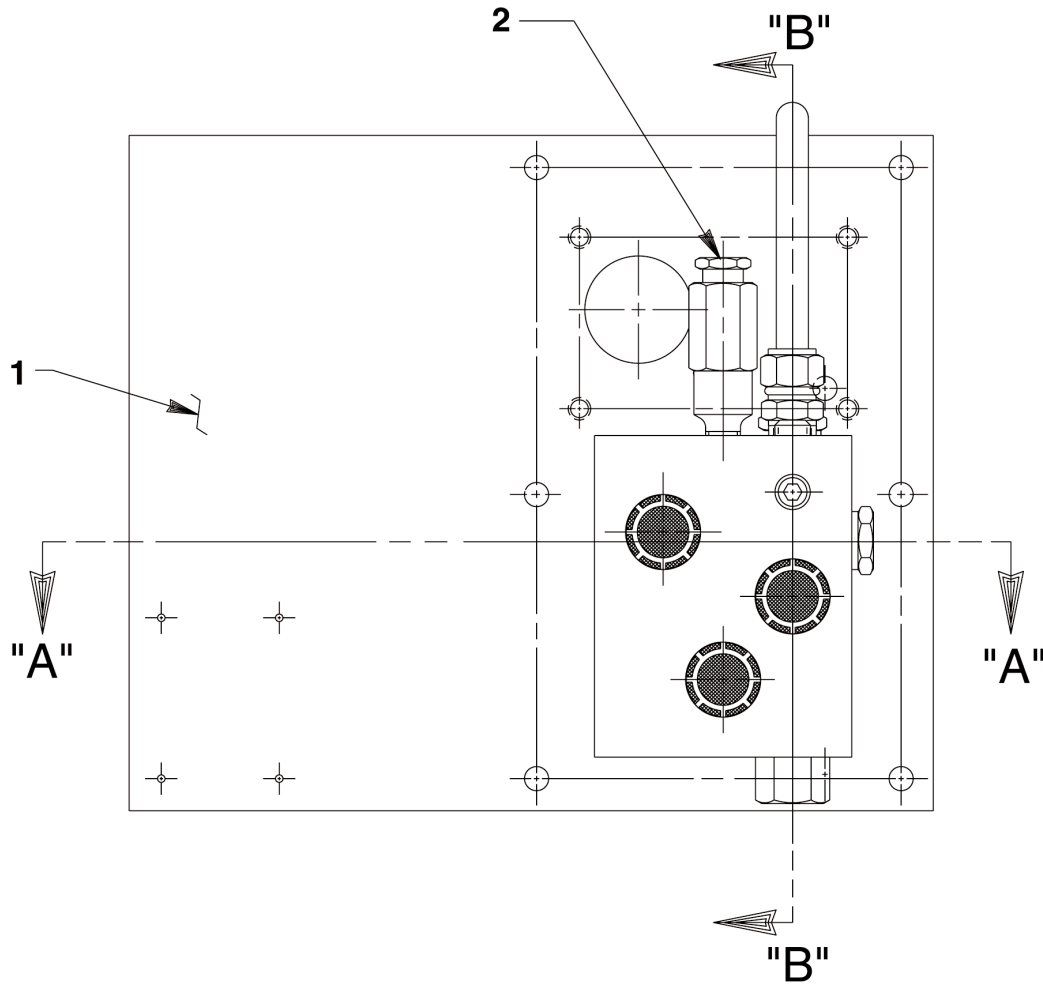

Item No.	Part No.	No. Req'd	Description
1	58790	1	Cover Plate
2	21278-83	1	Relief Valve Assembly (Set at 8,400/9,000 PSI)

HAND PUMP - SECTION A-A

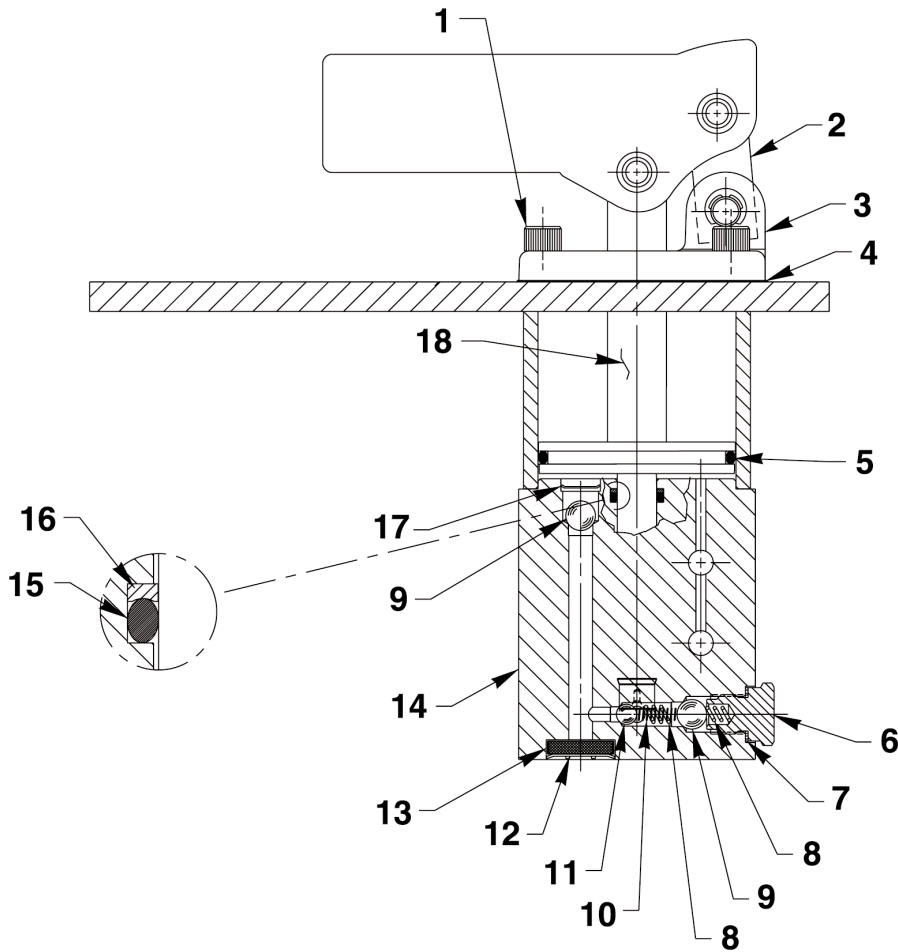

Item No.	Part No.	No. Req'd	Description
1	250671	4	Screw (5/16-24 UNF X 3-1/2 Lg.; Torque to 240/250 in. lbs. Note: Torque in increments of 100 in. lbs.)
2	21603	1	Pivot Block
3	420978BK2	1	End Cap
4	*22143	1	End Cap Gasket
5	*10295	1	O-ring (2-1/2 x 2-1/4 x 1/8)
6	305975	1	Valve Screw (Torque to 350/370 in. lbs.)
7	*14874	1	Soft Copper Washer (.700 X 1/2 X 1/32)
8	*10444	2	Compression Spring (3/16 I.D. X 13/32 Lg.)

Item No.	Part No.	No. Req'd	Description
9	*10378	3	Steel Ball (3/8 Dia.)
10	*211797	1	Spring (5/32 O.D. X 5/8 Lg.)
11	*10375	1	Steel Ball (1/4 Dia.)
12	*214586	3	Retaining Ring (Internal)
13	*214578	3	Filter (Insert screen with cupped side in.)
14	64202	1	Pump Body
15	*10271	1	O-ring (11/16 X 1/2 X 3/32)
16	*213987	1	Backup Washer (11/16 X 1/2 X 3/64)
17	*250670	2	Retaining Ring
18	*253372	1	High Pressure Piston

Part numbers marked with an asterisk (*) are contained in Repair Kit No. 301010.

HAND PUMP - SECTION B-B

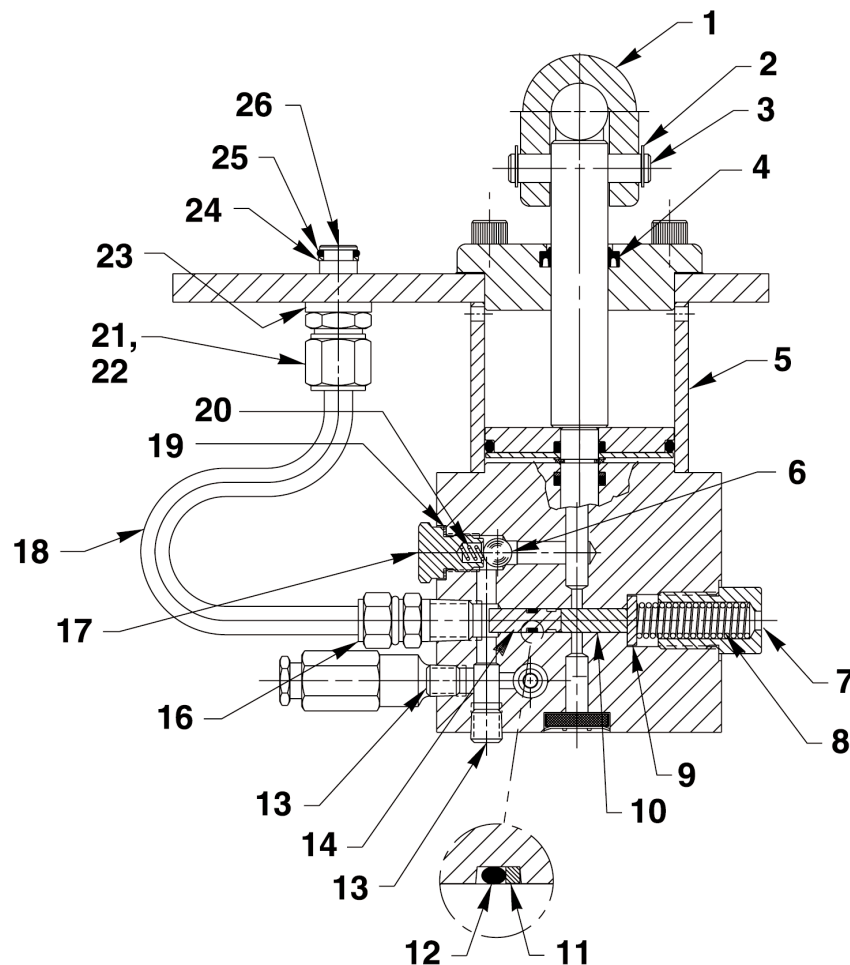

Item No.	Part No.	No. Req'd	Description	Item No.	Part No.	No. Req'd	Description
1	30701	1	Lever	16	10661	1	Straight Fitting
2	11032	6	Retaining Ring	17	305975	1	Valve Screw (Torque to 350/370 in. lbs.)
3	21609	3	Clevis Pin	18	351250	1	Oil Line
4	*251728	1	Rod Wiper	19	*14874	1	Soft Copper Washer (.700 X 1/2 X 1/32)
5	350302	1	Spacer	20	*10444	1	Compression Spring (3/16 I.D. X 13/32 Lg.)
6	*10378	1	Steel Ball (3/8 Dia.)	21	10430	1	Tube Sleeve
7	308430	1	Unloading Valve Fitting	22	10431	1	Tube Nut (Torque to 40/50 ft. lbs.)
8	10367	1	Compression Spring (1/2 O.D. X 2" Lg.)	23	21484	1	Spacer
9	214692	1	Disc	24	*11863	1	Backup Washer (1/2 X 3/8 X 1/16)
10	250672	1	Dowel Pin	25	*10268	1	O-ring (1/2 X 3/8 X 1/16)
11	*15174	1	Backup Ring	26	20787	1	Valve Connector (Torque to 20/30 ft. lbs.)
12	*10265	1	O-ring (5/16 X 3/16 X 1/16)				
13	10427	2	Pressure Plug (1/8 NPTF)				
14	250658	1	Unloading Valve Piston				

Part numbers marked with an asterisk (*) are contained in Repair Kit No. 301010.

DUAL MANUAL VALVE

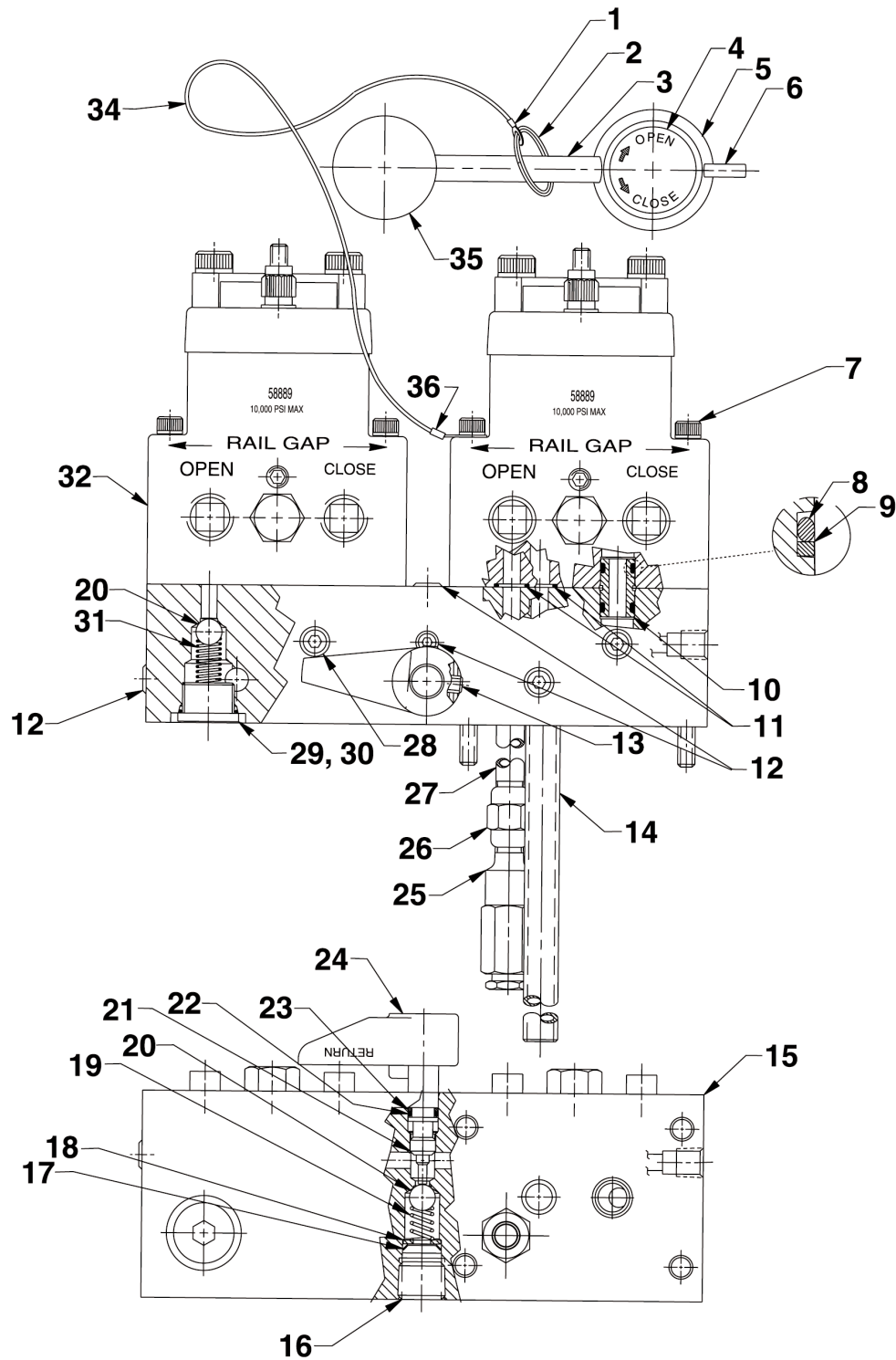

Item No.	Part No.	No. Req'd	Description	Item No.	Part No.	No. Req'd	Description
1	11208	1	Terminal	20	10378	2	Steel Ball (3/8 Dia.)
2	251756	1	Key Ring	21	304849	1	Release Valve Screw
3	21639	1	Stud (Note: Apply Loctite #242 to threads [both ends].)	22	15085	1	Backup Washer
4	*251733	1	Decal	23	10267	1	O-ring (7/16 X 5/16 X 1/16)
5	420996	1	Stem End	24	213109	1	Handle (See assembly instructions below.)
6	10714	1	Pin	25	21278-28	1	Relief Valve Assembly (Set at 2,700/3000 PSI)
7	251077	4	Cap Screw (1/4-20 UNC x 4-3/4 Lg.)	26	18841	1	Straight Fitting
8	*10268	4	O-ring (1/2 X 3/8 X 1/16)	27	14463	1	Pipe Fitting
9	*11863	4	Backup Washer (1/2 X 3/8 X 1/16)	28	14972	4	Pipe Plug (1/4 NPTF)
10	21094	2	Bushing	29	214014	1	Drive Plug (3/4-16 UNF)
11	*10301	4	O-ring (5/8 X 1/2 X 1/16)	30	215193	1	O-ring (13/16 X 5/8 X 3/32)
12	15130	3	Plug (1/16 NPTF)	31	10428	1	Compression Spring (1/2 O.D. X 3/4 Lg.)
13	10556	2	Set Screw (1/4-20 UNC X 1/4 Lg.; Torque to 30/50 in. lbs.)	32	58889	2	Manual Valve Assembly (See sheet 8 of 9)
14	200609	1	Drain Tube	34	251447	1 ft.	Aircraft Cable
15	65165	1	Manifold Block	35	211911	1	Plastic Knob
16	16232	1	Pipe Plug (3/8 NPTF)	36	14949	1	Terminal
17	11088	1	Retaining Ring				
18	206857	1	Special Washer (.53 x .21)				
19	11024	1	Compression Spring (1/4 O.D. X 5/8 Lg.)				

Part numbers marked with an asterisk (*) are contained in Repair Kit No. 301007.

INSTRUCTIONS FOR HANDLE ASSEMBLY

1. Turn the stem [Item #21] into the manifold body [Item #15] until the stem and ball [Item #20] just meet. (The ball must be against the seat.)
2. Back out the stem 15° / 20°.
3. Leave enough gap (approximately 9/16") between the handle and manifold body so there is still clearance when the handle is rotated in any position.
4. Torque set screws to 30/50 in. lbs.

VALVE HYDRAULIC SCHEMATIC

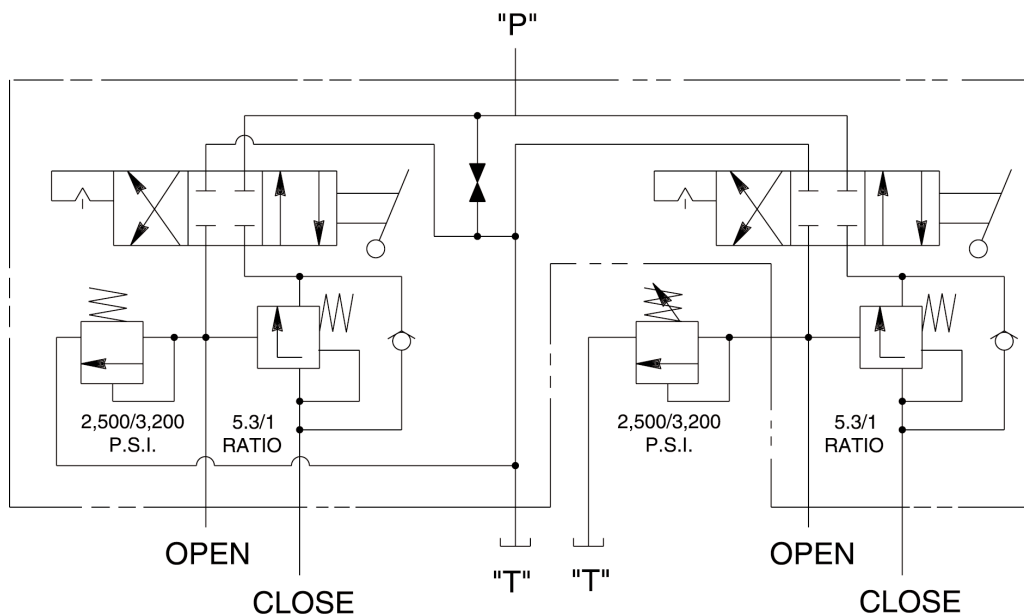

MANUAL VALVE

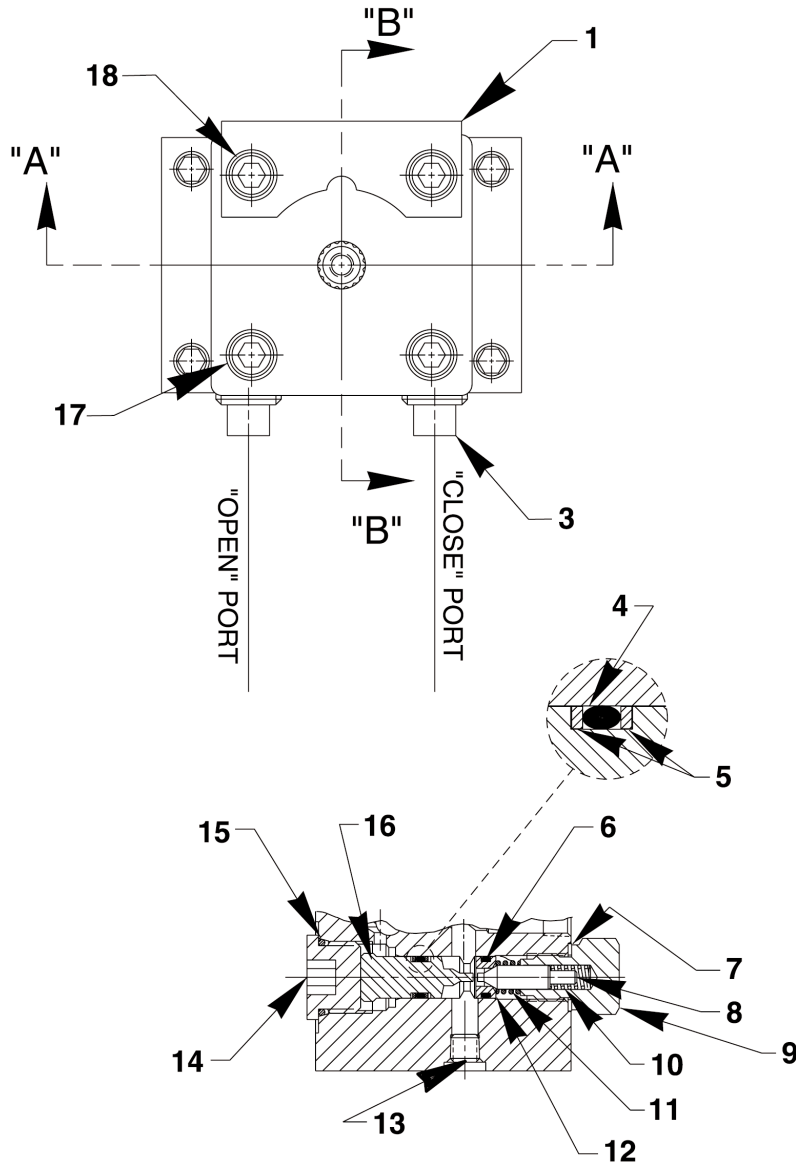

Item No.	Part No.	No. Req'd	Description
1	350982	1	Bracket
3	11127	2	Pressure Plug (3/8 NPTF)
4	*10267	1	O-ring (7/16 X 5/16 X 1/16)
5	*15085	2	Backup Ring
6	*14763	1	O-ring (7/16 X 5/16 X 1/16)
7	*14874	1	Soft Copper Washer (.700 X 1/2 X 1/32)
8	250020	1	Poppet
9	307136	1	Valve Screw (Torque to 250/280 in. lbs.)
10	11024	1	Compression Spring (1/4 O.D. X 5/8 Lg.)

Item No.	Part No.	No. Req'd	Description
11	250022	1	Compression Spring (7/16 O.D. X 13/32 Lg.)
12	250021	1	Seat
13	15130	4	Plug (1/16 NPTF)
14	214014	1	O-ring Plug (Note: Discard rubber o-ring.)
15	*215193	1	O-ring (13/16 X 5/8 X 3/32)
16	251592	1	Piston
17	11013	2	Cap Screw (Torque to 300/320 in. lbs.)
18	10948	2	Cap Screw (Torque to 300/320 in. lbs.)

Part numbers marked with an asterisk (*) are contained in Repair Kit No. 301007.

MANUAL VALVE - SECTION A-A

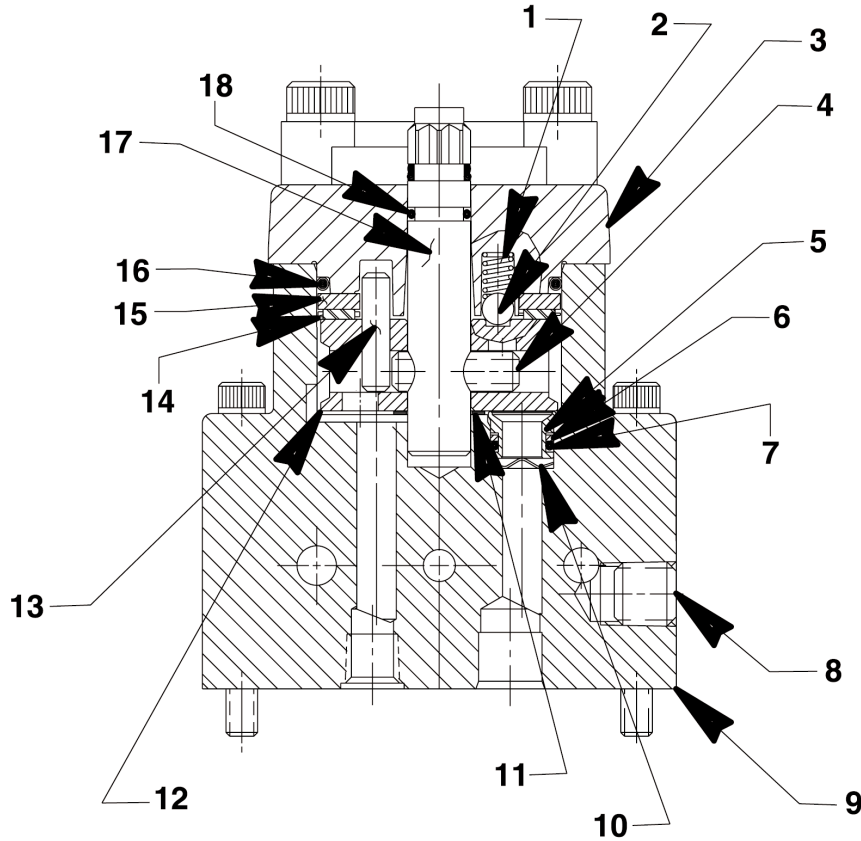

Item No.	Part No.	No. Req'd	Description
1	15691	1	Compression Spring (1/4 O.D. X 5/8 Lg.)
2	10375	1	Steel Ball (1/4 Dia.)
3	61343	1	Valve Cap
4	10496	1	Pin
5	202480	3	Seal
6	*11863	3	Backup Washer (1/2 X 3/8 X 1/16)
7	*10268	3	O-ring (1/2 X 3/8 X 1/16)
8	14972	1	Pipe Plug (1/4 NPTF)
9	64651	1	Valve Body
10	21975	3	Spring Washer

Item No.	Part No.	No. Req'd	Description
11	214801	1	Spacer Washer
12	306032	1	Rotor
13	250056	1	Pin
14	11228	1	Thrust Bearing
15	11227-1	1	Bearing Race
16	*15892	1	O-ring (1.956 X 1.720 X .118)
17	46048	1	Stem
18	*13943	1	O-ring (1/2 X 3/8 X 1/16)
19	10139	1	Set Screw (1/4-20 x 3/4 Lg.; Torque to 50/60 in. lbs. and Loctite 242 or equivalent.

Part numbers marked with an asterisk (*) are contained in Repair Kit No. 301007.

SAFETY DEFINITIONS

Safety symbols are used to identify any action or lack of action that can cause personal injury. Your reading and understanding of these safety symbols is very important.



DANGER - Danger is used only when your action or lack of action will cause serious human injury or death.



WARNING - Warning is used to describe any action or lack of action where a serious injury can occur.



DANGEROUS VOLTAGE - Dangerous voltage is used to describe any action or lack of action that could cause serious personal injury or death from high voltage electricity.

IMPORTANT - Important is used when action or lack of action can cause equipment failure, either immediate or over a long period of time.

SAFETY PRECAUTIONS

These instructions are intended for end-user application needs. Many problems with new equipment are caused by improper operation or installation. To locate a Power Team Authorized Hydraulic Service Center contact your nearest Power Team facility. A list of all Power Team facilities is located at the end of this document.





WARNING It is the operator's responsibility to read and understand the following safety statements,

- Only qualified operators should install, operate, adjust, maintain, clean, repair, or transport this machinery.
- These components are designed for general use in normal environments. These components are not specifically designed for lifting and moving people, agri-food machinery, certain types of mobile machinery or special work environments such as: explosive, flammable or corrosive. Only the user can decide the suitability of this machinery in these conditions or extreme environments. Power Team will supply information necessary to help make these decisions.



WARNING To help prevent personal injury,

GENERAL

-  Always wear eye protection whenever operating hydraulic equipment.
-  Always wear hearing protection as required.
- Operation, repair, or maintenance of hydraulic equipment should be performed by a qualified person who understands the proper function of hydraulic equipment per local directives and standards.
- Hydraulic equipment must be assembled correctly and then checked for proper function before use. Use hydraulic components of the same hydraulic pressure ratings. An appropriate hydraulic pressure gauge is recommended to monitor pressure.
-  Never place your hands or other body parts near a hydraulic fluid leak. Never use your hands or other body parts to check for a possible leak. High pressure fluid can be injected under your skin causing serious injury and/or infection.

SAFETY PRECAUTIONS (GENERAL) CONTINUED -

- High pressure fluid is present throughout a hydraulic system. Always use caution when operating, repairing, or maintaining this equipment. Before beginning any work on any hydraulic system component, stop the equipment, disconnect from its power source, and relieve all pressure in all parts of the system. Do not tamper with the internal hydraulic relief valve settings.
- Avoid exposing hydraulic equipment (especially hoses) to extreme high or low temperatures. Damage to equipment or failure may result and cause loss of control or injury to the operator.
-  Exercise caution to avoid the risk of fire.
- Do not drop any hydraulic system components. Damage to the equipment and/or injury may result.
- Avoid slipping or falling by cleaning up any oil spills.
- Avoid back injury by always lifting equipment carefully.
- It is strongly recommended to view the Power Team Hydraulic Safety video tape before using hydraulic equipment.

Gasoline Engine



No Smoking



No Open Flame



Flammable

- Read the instruction manual for the gasoline engine before using for correct operating procedure.
- Turn off the engine and relieve pressure when not in use or when working on any part of the system.
- Proper ventilation is critical during refueling.
- Do not allow fuel to splash on the engine when refueling.
- Do not add fuel when the engine is running or hot.

HYDRAULIC HOSES AND FLUID TRANSMISSION LINES

- Avoid straight line tubing connections in short runs. Straight line runs do not provide for expansion and contraction due to pressure and/or temperature changes. See diagrams in “Set-up Instructions” section of this form.
- Eliminate stress in the tube lines. Long tubing runs should be supported by brackets or clips. Tubes through bulkheads must have bulkhead fittings. This makes easy removal possible and helps support the tubing.
- Before operating the pump, all hose connections must be tightened with the proper tools. Do not overtighten. Connections should only be tightened securely and leak-free. Overtightening can cause premature thread failure or high pressure fittings to split at pressures lower than their rated capacities.
- Should a hydraulic hose ever rupture, burst, or need to be disconnected, immediately shut off the pump and release all pressure. Never attempt to grasp a leaking pressurized hose with your hands. The force of escaping hydraulic fluid could cause serious injury.
- Do not subject the hose to potential hazard such as fire, sharp surfaces, extreme heat or cold, or heavy impact. Do not allow the hose to kink, twist, curl, crush, cut, or bend so tightly that the fluid flow within the hose is blocked or reduced. Periodically inspect the hose for wear, because any of these conditions can damage the hose and possibly result in personal injury. Never repair with tape.
- Do not use the hose to move attached equipment. Stress can damage the hose and possibly cause personal injury.
- Hose material and coupler seals must be compatible with the hydraulic fluid used. Hoses also must not come in contact with corrosive materials such as creosote-impregnated objects and some paints. Hose deterioration due to corrosive materials can result in personal injury. Consult the manufacturer before painting a hose. Never paint a coupler.

SAFETY PRECAUTIONS (GENERAL) CONTINUED -**PUMP**

- Do not exceed the hydraulic pressure rating noted on the pump nameplate or tamper with the internal high pressure relief valve. Creating pressure beyond rated capacities can result in personal injury.
- Before replenishing the fluid level, retract the system to prevent overfilling the pump reservoir. An overfill can cause personal injury due to excess reservoir pressure created when the cylinders are retracted.
- Always shut off the engine and relieve pressure before breaking any connections in the system.
- The engine is the major part of the weight of the pump. Always take this into consideration when lifting or moving the pump.

CYLINDER

- Do not exceed the rated capacities of the cylinders. Excess pressure can result in personal injury.
- Do not set poorly balanced or off-center loads on a cylinder. The load can tip and cause personal injury.
- Read and understand the cylinder operating instructions and warning decals before using the cylinder.



DANGER A double-acting cylinder or ram must have both hoses and all couplers securely connected to both ports. If one of the two ports is restricted or becomes disconnected, pressure will build and the cylinder, hose or coupler can burst, possibly causing serious injury or death.

HYDRAULIC FLUIDS

- Properly dispose of all fluids, components, and assemblies at the end of their useful life.
- Hydraulic fluid should be compatible with all hydraulic components.

SET-UP INSTRUCTIONS

Filling The Pump Reservoir

NOTE: Most pumps are shipped without hydraulic fluid in the reservoir. Hydraulic fluid may have been shipped with the pump in a separate container. If hydraulic fluid is needed, use 215 SSU @ 100° F (47 cSt @ 38° C) hydraulic fluid.

1. Clean the area around the filler cap to remove all dust and grit. Any dirt or dust in the hydraulic fluid can damage the polished surfaces and precision-fit components of this pump.
2. Retract all cylinder(s) to their return position.
3. Remove the filler cap and insert a clean funnel with a filter. Fill the reservoir with hydraulic fluid.

Hydraulic Connections

Remove the thread protectors or dust covers from the hydraulic ports if applicable. Clean the areas around the fluid ports of the pump and cylinder. Inspect all threads and fittings for signs of wear or damage, and replace as needed. Clean all hose ends, couplers and union ends. Connect all hose assemblies to the pump and cylinder. Use an approved, high-grade pipe thread sealant to seal all hydraulic connections. Tighten securely and leak-free but do not overtighten.

Hydraulic lines and fittings can act as restrictors as the cylinder or ram retracts. The restricting or slowing of the fluid flow causes back pressure that slows the cylinder's or ram's return. Return speed also varies because of the application, condition of the cylinder or ram, inside diameter of hose or fitting, length of the hose, and the temperature and viscosity of the hydraulic fluid.

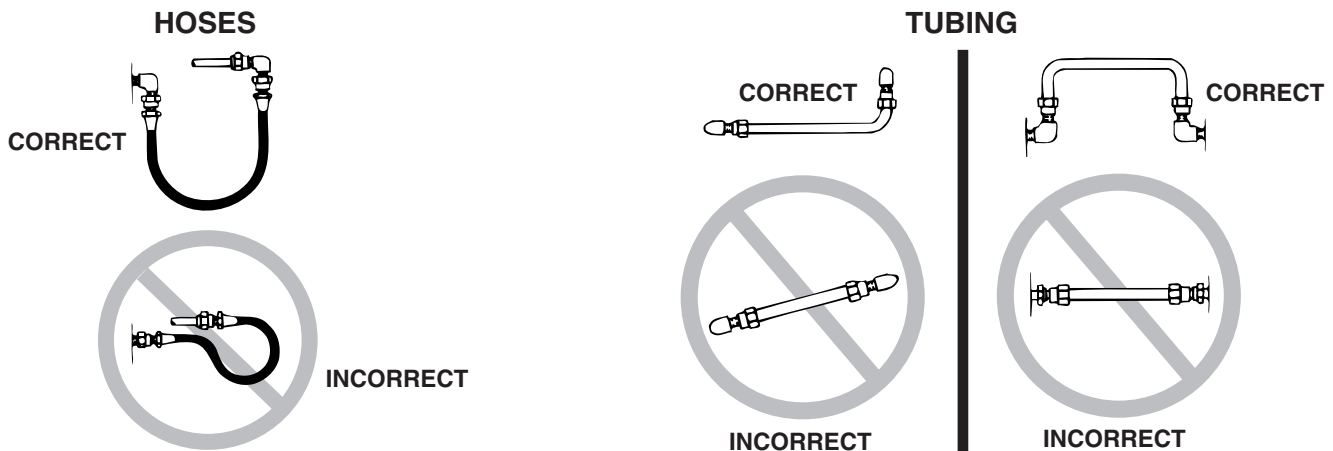

Bleeding The System

After all connections are made, the hydraulic system must be bled of any trapped air. Refer to the diagrams below.

With no load on the system and the pump vented and positioned higher than the cylinder or ram, cycle the system several times. Check the reservoir for possible low fluid level and fill to proper level with approved, compatible hydraulic fluid as necessary (see "Filling The Pump Reservoir" section under Set-up Instructions).

IMPORTANT: Some spring return cylinders or rams have a cavity in the rod which forms an air pocket. This type of cylinder or ram should be bled when positioned upside down or lying on its side with the port facing upward.

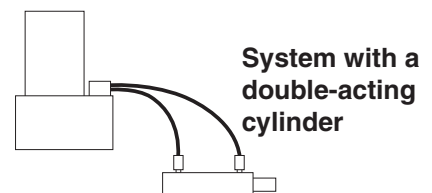
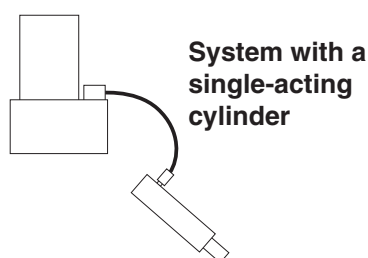

PUMP OPERATION

When operating the pump for the first time:

1. Valve and hose connections must be tight, and the reservoir must be filled to the proper fluid level. Start the motor.
2. Jog the pump several times to build pressure.
3. Run cylinder out to its full travel several times to eliminate air from the system. For more complete instructions, refer to the section titled "Bleeding The System" under Set-up Instructions.
4. With the cylinder(s) retracted completely, check the fluid level in the reservoir and add fluid if necessary. Refer to "Filling The Pump Reservoir" under Set-up Instructions.
5. The pump is now ready to be put into regular operation.



DANGER

When lifting or lowering a load, the load must be under operator control at all times and others must be clear of the load. Use blocking and cribbing to guard against a falling load.

Do not drop the load. The use of a load lowering or metering valve is recommended in addition to the pump directional control valve.

GAS PUMP

Gasoline-Powered: Consult the instruction manual for the gasoline engine to determine its specifications.

1. Place the valve in the neutral or hold position.
2. Start the gas engine according to the operating instruction manual provided.
3. When the engine is running properly, shift the valve as necessary.
4. Turn the pump off when not in use.

HAND PUMP OPERATION

IMPORTANT: Figure 1 illustrates the *normal* drop of handle effort experienced when all two-stage pumps shift from low pressure stage to high pressure stage.

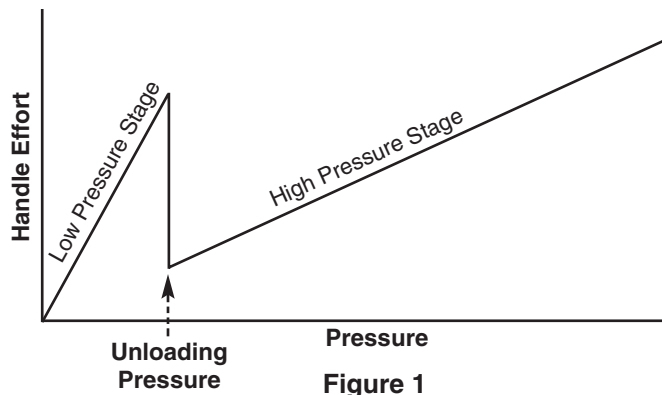

Two-way Valve

Pumps with a two-way valve are for use with single-acting cylinders.

1. To extend the cylinder, turn the valve knob counterclockwise to a closed (seated) position. **Note: Hand tight only!** Work the pump handle up and down to build pressure.
2. To release pressure, open the valve slowly by turning the knob clockwise to control the load.



WARNING The operator should always release the pressure slowly.

3 POSITION, 4-WAY MANUAL VALVE OPERATION

NOTE: • Some valves return fluid to the reservoir when the pump stops or when the valve is shifted.



DANGER

When lifting or lowering a load, the load must be under operator control at all times and others must be clear of the load. Use blocking and cribbing to guard against a falling load. Do not drop the load. The use of a load lowering or metering valve is recommended in addition to the pump directional control valve.

Valve, Manual mounted, manual detented, 3-position, 4-way, closed center with "OPEN" port release system. (5.3 to 1 ratio)

Rated Pressure: 10,000 PSI

Case Pressure: 500 PSI

Rated Flow: 5 GPM

FUNCTION:

Center Position: All parts blocked.

"CLOSE" Position: Pressure to "CLOSE" port; "OPEN" port to tank.

"OPEN" Position: Pressure to "OPEN" port.

"CLOSE" port to hold until pressure ratio is obtained and then releases to tank.

"CLOSE" port will remain open as long as "OPEN" port maintains pressure ratio.

NOTE: "CLOSE" port is blocked with "OPEN" and pressure ports open to tank during transition between valve positions. Pressure ratio is the pressure differential in the "CLOSE" and "OPEN" ports.

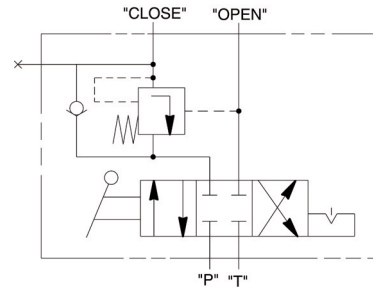

HYDRAULIC SCHEMATIC

INTERNAL ASSEMBLY ORIENTATION OF PARTS

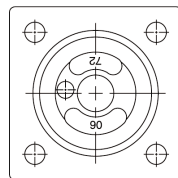

END CAP
BOTTOM VIEW

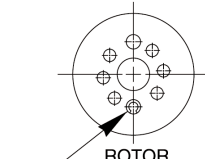

ROTOR
TOP VIEW

ROLL PIN LOCATION
(POSITION OPENING AS SHOWN)

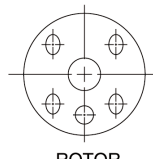

ROTOR
BOTTOM VIEW

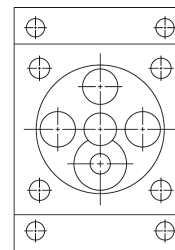

VALVE BODY
TOP VIEW

PREVENTIVE MAINTENANCE



WARNING

To help prevent personal injury,

- Disconnect the pump from the power supply before performing maintenance or repair procedures.
- Repairs and maintenance are to be performed in a dust-free area by a qualified technician.

Checking The Hydraulic Fluid And Filling The Reservoir

The hydraulic fluid level should be checked after initial set-up and after each ten hours of use.

1. Thoroughly clean the area around the filler cap with a clean cloth to prevent contamination of the hydraulic fluid.
2. Cylinder(s) must be fully retracted and the power supply disconnected.
3. Remove the filler cap and insert a clean funnel with filter. Fill to proper level as instructed in "Filling The Pump Reservoir" under Set-up Instructions.
4. Replace filler cap.
5. The frequency of fluid changes will depend upon the general working conditions, severity of use, and overall cleanliness and care given the pump. Three hundred hours of use under general shop conditions is considered a standard change interval. Drain, clean, and refill the reservoir with a high grade hydraulic fluid.

Maintenance Cleaning

IMPORTANT: Never use a high pressure washer to clean hydraulic components!

1. Keep the pump's outer surface as free from dirt as possible.
2. Seal all unused couplers with thread protectors.
3. Keep all hose connections free of dirt and grime.
4. The breather-hole in the filler cap must be clean and unobstructed at all times.
5. Equipment connected to the pump must be kept clean.
6. Use a high grade hydraulic fluid in this pump. Change as recommended (every 300 hours). Some conditions may require the use of different viscosity hydraulic fluids.

Engine Oil

Change engine oil as recommended for four stroke engines.

Draining And Cleaning The Reservoir

IMPORTANT: Clean the pump exterior before the pump interior is removed from the reservoir.

1. Remove the screws fastening the motor and pump assembly to the reservoir. **IMPORTANT: Do not damage the gasket or pump filter when lifting the pump and motor off the reservoir.**
2. Clean the inside of the reservoir and clean the filter.
3. Place the pump and motor assembly back onto the reservoir, and secure with machine screws.
4. Fill the reservoir with a clean, high grade hydraulic fluid (refer to "Filling The Pump Reservoir" under Set-up Instructions for proper fluid level for your pump).

Lubrication

Apply lubricant regularly to all pivot and rubbing points. Use a good grade of No. 10 motor oil or grease. Do not use dry lubricants.

TROUBLE-SHOOTING GUIDE

WARNING

- To help prevent personal injury, any repair work or trouble-shooting must be done by qualified personnel familiar with this equipment.
- Use the proper gauges and equipment when trouble-shooting.

NOTE:

- To locate a Power Team Authorized Hydraulic Service Center contact your nearest Power Team facility.
- It is best to check for system leaks by using a hand pump and applying pressure to the suspect area. Watch for leaking fluid and follow it back to its source. *Never* use your hand or other body parts to check for a possible leak.

PROBLEM	CAUSE	SOLUTION
Pump is not delivering fluid or delivers only enough fluid to advance cylinder(s) partially or erratically.	1. Fluid level too low.	1. Fill reservoir or bladder according to directions "Filling The Pump Reservoir Or Bladder" under "Set-up Instructions" section
	2. Quick disconnect couplings are not completely coupled.	2. Check quick-disconnect couplings to cylinders to ensure that they are completely coupled. Occasionally couplers have to be replaced because the ball check does not stay open due to wear.
	3. Air in system.	3. Refer to the section titled "Bleeding the System" under "Set-up Instructions" section.
	4. Cold fluid or fluid too viscous.	4. Hydraulic fluid is of a higher viscosity than necessary. Change to a lighter fluid.
	5. Reservoir capacity is too small for the size of cylinder(s) used.	5. Use smaller cylinder(s) or larger reservoir.
	6. Vacuum in reservoir.	6. Check for plugged vent in filler plug.
Pump builds pressure but cannot maintain pressure.	1. External leaks.	1. Seal leaking pipe fittings with pipe sealant. Replace leaking pipes or hoses.
	2. Internal or external leakage on hydraulic cylinder.	2. Remove the cylinder from pump. If the pump builds and maintains full pressure, the cylinder is defective. Contact a Power Team Authorized Hydraulic Service Center.
	3. Leaking control valve	3. Contact a Power Team Authorized Hyd. Service Center.

TROUBLE-SHOOTING GUIDE CONTINUED -

PROBLEM	CAUSE	SOLUTION
Pump will not build full pressure.	<ol style="list-style-type: none"> Faulty pressure gauge. Check for external leakage. Internal or external leakage on hydraulic cylinder. Leaking control valve or defective pump. 	<ol style="list-style-type: none"> Calibrate gauge. Seal faulty fittings with sealant. Replace leaking pipes or hoses. Remove the cylinder from the pump. If the pump builds full pressure, the cylinder is defective. Contact a Power Team Authorized Hyd. Service Center. Contact a Power Team Authorized Hydraulic Service Center.
Cylinder(s) will not retract or extend.	<ol style="list-style-type: none"> Quick disconnect couplings are not completely coupled.  WARNING A double-acting cylinder or ram must have <i>both</i> hoses and all couplers securely connected to both ports. If one of the two ports is restricted or becomes disconnected, pressure will build and the cylinder, hose or coupler can burst, possibly causing serious injury or death. Broken return spring in spring return cylinder or seals blown in double-acting cylinder. 	<ol style="list-style-type: none"> Check quick disconnect coupling to cylinders to ensure that they are completely coupled. Occasionally couplers have to be replaced because the ball check does not stay open due to wear. Contact a Power Team Authorized Hydraulic Service Center.
Pump delivers excess oil pressure.	<ol style="list-style-type: none"> Faulty pressure gauge. Relief valve not properly set. 	<ol style="list-style-type: none"> Calibrate gauge. Contact a Power Team Authorized Hydraulic Service Center.

TROUBLE-SHOOTING GUIDE (FOR HAND PUMP) CONTINUED -

PROBLEM	CAUSE	SOLUTION
Pump losing pressure	<ol style="list-style-type: none"> 1. System components leaking 2. Directional control valve leaks or not adjusted properly 3. Fluid leaking past outlet check seat(s) 	<ol style="list-style-type: none"> 1. Repair or replace as necessary 2.* Reseat, repair, or replace directional control assembly and correctly adjust 3.* Check for dirt. Reseat pump body and/or replace poppet(s) or ball(s)
Handle rises after each stroke	<ol style="list-style-type: none"> 1. Fluid leaking past outlet check seat(s) 	<ol style="list-style-type: none"> 1.* Check for dirt. Reseat pump body and/or replace poppet(s) or ball(s)
Pump not delivering fluid	<ol style="list-style-type: none"> 1. Low fluid level in reservoir 2. Intake filter is dirty 3. Seats worn and not seating properly 	<ol style="list-style-type: none"> 1. Check fluid level per instructions 2. Remove reservoir and clean 3.* Repair seats or replace pump body
Pump does not reach full pressure	<ol style="list-style-type: none"> 1. Low fluid level in reservoir 2. System components leaking 3. Directional control valve leaks or not adjusted properly 4. Improperly adjusted relief valve 5. Fluid leaking past inlet or outlet checks or high pressure piston seal damaged 	<ol style="list-style-type: none"> 1. Check fluid level per instructions 2. Repair or replace as necessary 3.* Reseat, repair, or replace directional control assembly and correctly adjust 4.* Readjust 5.* Reseat or repair inlet or outlet checks or replace high pressure piston seal
Pump handle can be pushed down (slowly) without raising the load	<ol style="list-style-type: none"> 1. Inlet checks are not seating 2. Damaged piston assembly or piston seals leaking 	<ol style="list-style-type: none"> 1.* Check for dirt and/or reseat valve seats 2.* Replace piston assembly and/or piston seals
Pump handle operates with a spongy action	<ol style="list-style-type: none"> 1. Air trapped in system 2. Too much fluid in reservoir 	<ol style="list-style-type: none"> 1. Position cylinder lower than pump. Extend and return cylinder several times. Follow bleeding instructions. 2. Check fluid level per instructions
Pump handle effort drops significantly after some pressure has been obtained	<ol style="list-style-type: none"> 1. This is normal operation on most two-stage hand pumps 	

*Power Team recommends these hand pump repairs be performed by an Authorized Hydraulic Service Center.

POWER TEAM FACILITIES



**UNITED
STATES**

SPX Corporation-Fluid Power
5885 11th Street
Rockford, IL 61109-3699
USA
Telephone: 1-815-874-5556
FAX: 1-815-874-7853

Cust. Service/Order Entry

Tel: 1-800-541-1418
FAX: 1-800-288-7031

E-mail:

info@fluidpower.spx.com

Technical Services

Tel: 1-800-477-8326
FAX: 1-800-765-8326



CHINA

212 Jiang Ning Road
CATIC Tower 23C
Shanghai 200041, China
Tel: 86 (21) 5289 5858
FAX: 86 (21) 5289 5866

E-mail:

info.asia@fluidpower.spx.com



EUROPE

Albert Thijsstraat 12
6471 WX Eygelshoven
Netherlands

Tel: 31 (45) 5678877
FAX: 31 (45) 5678878

E-mail

info.europe@fluidpower.spx.com



**FAR
EAST**

7 Gul Circle
Singapore 629563
Singapore
Tel: (65) 6265-3343
FAX: (65) 6265-6646

E-mail:

info.asia@fluidpower.spx.com

For more information, Internet address: <http://www.powerteam.com> (or) <http://www.hytec.com>