

PHP8 & PHP30 Series Hydraulic Pushers

Note:

These instructions must be read and carefully followed.

Carefully inspect the pusher upon arrival. The carrier, not the manufacturer, is responsible for any damage resulting from shipment.

SAFETY PRECAUTIONS



WARNING To help prevent personal injury,

- These pushers should be used only by trained personnel familiar with them.
- Safety glasses must be worn at all times by the operator and anyone within sight of the pusher.
- Select the proper size and capacity of pusher for the job.
- Align the pusher on the same centerline as the part being removed. Failure to align parts correctly can result in a dangerous operating situation because of the high hydraulic pressures used.
- Wrap the work in a Power Team protective blanket before applying pressure to provide protection from injury caused by flying parts should a part ever break.
- Always apply force gradually.



	REACH (MM)	SPREAD (MM)	BORE (MM)
PHP8	55-385	58-270	85-150
PHP30	N/A	N/A	N/A

Specification Chart

IMPORTANT

DO NOT USE HEAT, HAMMERS, OR IMPACT TOOLS ON THESE PUSHERS. THIS WILL CAUSE DAMAGE THAT VOIDS THE PUSHERS WARRANTY.

PUSHER SET-UP AND OPERATION (INSTALLING PART TO SHAFT)

1. Select the proper size and capacity of pusher needed for the job. This is determined by measuring "reach" and "spread" of the part to be pushed.
2. Fasten pusher adapter to center of shaft.
3. Starting with shortest set of legs, insert pusher into adapter.
4. Begin to align legs with inside diameter of part, and center pusher with shaft, by turning hydraulic cylinder clockwise to remove slack. Make final pusher positioning adjustments. Allow minimal amount of clearance for outside diameter of shaft to slide between pusher legs. **NOTE: Insufficient clearance may cause damage to outside diameter of shaft.**

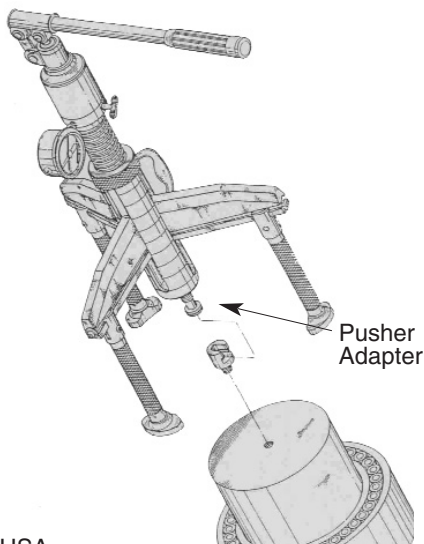

PUSHER SET-UP AND OPERATION (cont.)

(INSTALLING PART TO SHAFT)

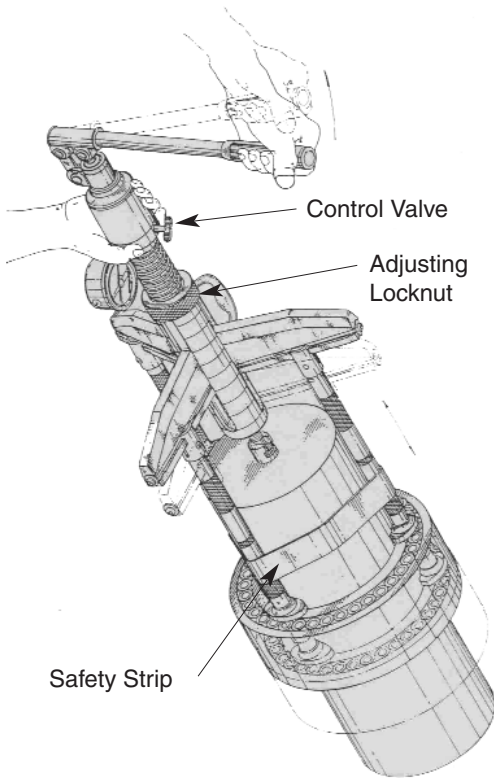

PUSHER SET-UP AND OPERATION (cont.) **(INSTALLING PART TO SHAFT)**

5. Turn adjusting locknut clockwise to lock hydraulic cylinder in place.
6. Fasten safety strip and protective blanket around legs.
7. **PHP8H Series:** Close control valve by turning knob counter-clockwise. To install part to shaft, apply pressure to hydraulic cylinder by pumping handle
PHP8R Series: Remove dust covers from couplers. Push male and female halves together at each connection and spin the threaded sleeve of the female half securely onto the threaded portion of the male half.
NOTE: With connections properly made, ball check valves in both halves of coupler are open to permit free flow of oil in either direction.
Apply pressure to hydraulic cylinder with an external hydraulic power source with a relief valve set @ 10,000 psi.
8. During part installation, longer or additional pusher legs may be added to correctly position part on shaft.
NOTE: Pressure must be relieved in cylinder before performing this operation.
9. After installation, relieve pressure in cylinder and remove pusher and pusher adapter from shaft.

INTERNAL PULLER SET-UP AND OPERATION **(REMOVING PART FROM BORE)**

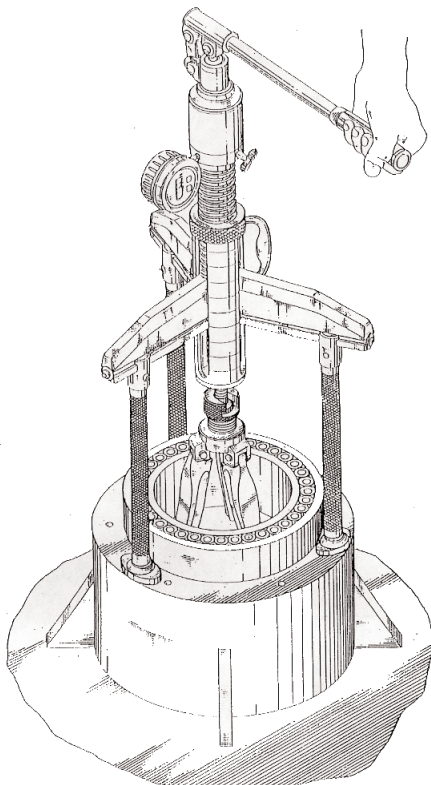

1. Adjust legs of internal puller to fit snug in inner diameter of part.
2. Select the proper size and capacity of pusher needed for the job. This is determined by measuring "reach" and "spread" of the part to be pushed.
3. Starting with longest set of legs required to remove part, insert pusher into internal puller adapter.
4. Begin to align legs around outside diameter of bore, and center pusher with bore, by turning hydraulic cylinder clockwise to remove slack. Make final pusher positioning adjustments. Allow minimal amount of clearance for outside diameter of part to slide between pusher legs.
NOTE: Insufficient clearance may cause damage to outside diameter of part.
5. Turn adjusting locknut clockwise to lock hydraulic cylinder in place.
6. Wrap pusher with safety blanket.
7. **PHP8H Series:** Close control valve by turning knob clockwise. To install part to shaft, apply pressure to hydraulic cylinder by pumping handle.
PHP8R Series: Remove dust covers from couplers. Push male and female halves together at each connection and spin the threaded sleeve of the female half securely onto the threaded portion of the male half.

INTERNAL PULLER SET-UP AND OPERATION (cont.)

(REMOVING PART FROM BORE)

7. (cont.) **NOTE: With connections properly made, ball check valves in both halves of coupler are open to permit free flow of oil in either direction.** Apply pressure to hydraulic cylinder with an external hydraulic power source with a relief valve set @ 10,000 psi. **NOTE: Puller must be supported by lifting device when removing part.**
8. During part removal, shorter or additional pusher legs may be removed to fully extract part from bore. **NOTE: Pressure must be relieved in cylinder before performing this operation.** After part removal, relieve pressure in cylinder and remove pusher from internal puller. Remove puller from center of part.

EXTERNAL PULLER SET-UP AND OPERATION

(REMOVING PART FROM SHAFT)

NOTE: Some kits include a 2-3 jaw puller head. The 3 jaw combination is strongly recommended whenever the job space allows for it. Three jaws give a more secure grip and more even pulling force. When using the trisection press plate the 3 jaw combination must ALWAYS be used.

1. Position trisection press plate on opposite side of part to be removed. Adjust to allow a minimal amount of clearance for outside diameter of shaft to slide between plates.
NOTE: Insufficient clearance may cause damage to outside diameter of shaft.
2. Fully engage jaws of puller head around trisection press plate, and center puller with shaft, by turning hydraulic cylinder clockwise to remove slack. Make final puller positioning adjustments and tighten adjusting locknut against bottom side of puller frame.
NOTE: The adjusting locknut must be fully engaged with the threads of the cylinder body.
3. Fasten safety blanket around puller legs.
4. PHP8H Series: Close control valve by turning knob clockwise. To remove part from shaft, apply pressure to hydraulic cylinder by pumping handle.
PHP8R Series: Remove dust covers from couplers. Push male and female halves together at each connection and spin the threaded sleeve of the female half securely onto the threaded portion of the male half.
NOTE: With connections properly made, ball check valves in both halves of coupler are open to permit free flow of oil in either direction.
Apply pressure to hydraulic cylinder with an external hydraulic power source with a relief valve set @ 10,000 psi.
NOTE: Puller must be supported by lifting device when removing part.
5. After part removal, relieve pressure in cylinder and remove puller from trisection press plate.

8 Ton (360206) & 30 Ton (360216) Pusher Parts List

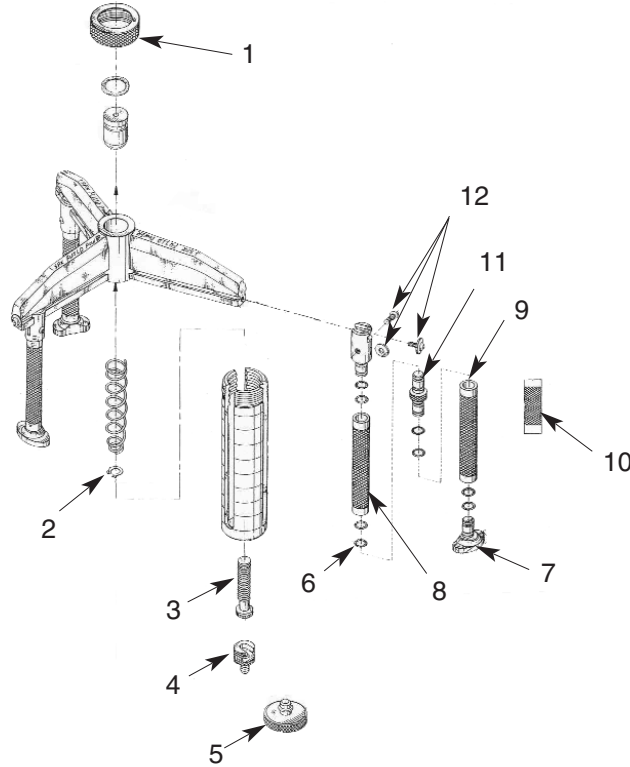

Item No.	Part No.	No. Req'd	Description
1	260397	1	Locknut, Adjusting (8 Ton)
	260371	1	Locknut, Adjusting (30 Ton)
2	260221	1	Retaining Ring, Pusher (8 Ton)
	260363	1	Retaining Ring, Pusher (30 Ton)
3	260217	1	Bolt, Pusher (8 Ton)
	260359	1	Bolt, Pusher (30 Ton)
4	260218	1	Adapter, Pusher (8 Ton)
	260360	1	Adapter, Pusher (30 Ton)
5	260219	1	Pad w O-ring, Pusher (8 Ton)
	260361	1	Pad w O-ring, Pusher (30 Ton)
6	*260213	1	O-ring, Pusher (8 Ton)
	*260355	1	O-ring, Pusher (30 Ton)
7	† 260209	1	Foot, Pusher (8 Ton)
	† 260351	1	Foot, Pusher (30 Ton)
8	† 260214	1	Leg, Pusher (230mm) (8 Ton)
	† 260356	1	Leg, Pusher (600mm) (30 Ton)
9	† 260207	1	Leg, Pusher (160 mm) (8 Ton)
	† 260349	1	Leg, Pusher (200mm) (30 Ton)
10	† 260208	1	Leg, Pusher (90 mm) (8 Ton)
	† 260350	1	Leg, Pusher (100mm) (30 Ton)
11	† 260210	1	Adapter, Pusher Leg (8 Ton)

Item No.	Part No.	No. Req'd	Description
	† 260352	1	Adapter, Pusher Leg (30 Ton)
12	† 260216	1	Roller & Hardware, Pusher (8 Ton)
	† 260353	1	Roller & Hardware, Pusher (30 Ton)

Additional Items (not shown)

260302	1	Carrying Case for PHP8, PHP8H, PHP8R
260222	1	Carrying Case for PHP30
260303	1	Carrying Case for PHP8-1 PHP8R-1
260346	1	Decal, PHP30H Case
260305	1	Decal, PHP8 Case
260341	1	Decal, PHP30R Case
260212	1	Decal, PHP8H Case
260215	1	Decal, PHP8R Case
260308	1	Decal, PHP8H-1 Case
260306	1	Decal, PHP8R-1 Case

Part numbers marked with an asterisk (*) are contained in a Kit with quantities of 25.
 Part numbers marked with a (†) are contained in a Kit with quantities of 3.

8 Ton (360207) & 30 Ton (360211) Self-contained Hydraulic Cylinder Parts List

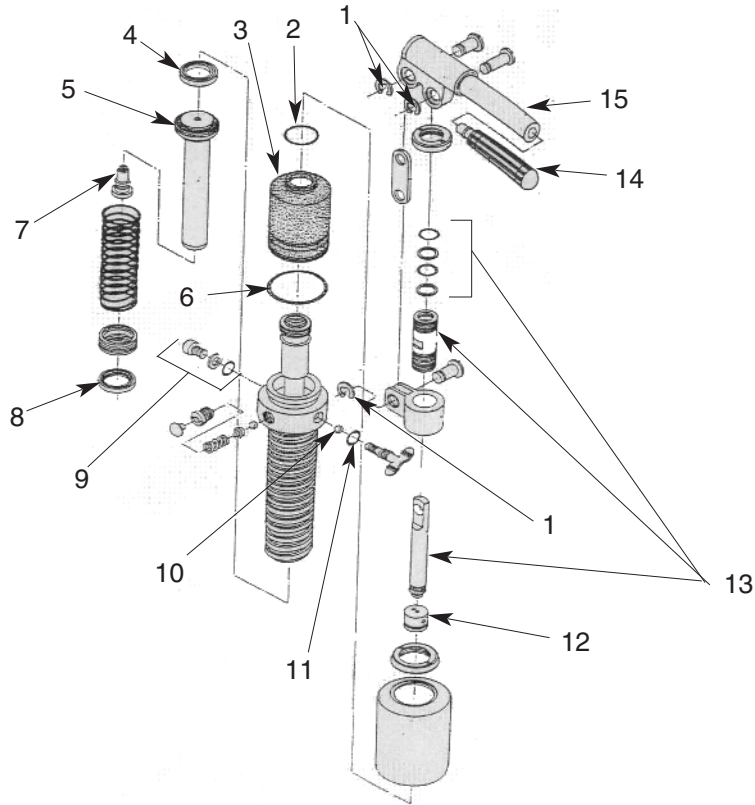

Item No.	Part No.	No. Req'd	Description
1	252932	3	Retaining Ring (8 Ton)
	260331	3	Retaining Ring (30 Ton)
2	*252887	1	Compression Ring (Small) (8 Ton)
	†260332	1	Compression Ring (Small) (30 Ton)
3	*252906	1	Reservoir Bladder (8 Ton)
	†260333	1	Reservoir Bladder (30 Ton)
4	*252938	1	U-Cup (8 Ton)
	†260338	1	U-Cup (30 Ton)
5	252892	1	Puller Piston Rod (8 Ton)
	260340	1	Puller Piston Rod (30 Ton)
6	*252889	1	Compression Ring (Large) (8 Ton)
	†260334	1	Compression Ring (Large) (30 Ton)
7	252930	1	Removable Cone Ass'y (8 Ton)
	260318	1	Removable Cone Ass'y (30 Ton)
8	*252934	1	Rod Wiper (8 Ton)
	†260342	1	Rod Wiper (30 Ton)
9	*252900	1	Oil Fill Screw Ass'y (8 Ton)
	†260335	1	Oil Fill Screw Ass'y(30 Ton)
10	252916	1	Steel Ball (8 Ton)
	260337	1	Steel Ball(30 Ton)

Item No.	Part No.	No. Req'd	Description
11	*252902	1	O-ring (8 Ton)
	†260329	1	O-ring (30 Ton)
12	*252913	1	Inlet/Outlet Valve Ass'y (8 Ton)
	†260325	1	Inlet/Outlet Valve Ass'y (30 Ton)
13	*252914	1	Pump Housing/Piston Rod (8 Ton)
	†260323	1	Pump Housing/Piston Rod (30 Ton)
14	252957	1	Handle Grip Ass'y (8 Ton)
	260345	1	Handle Grip Ass'y (30 Ton)
15	252936	1	Handle Lever (8 Ton)
	260321	1	Handle Lever (30 Ton)

Additional Items (not shown)

260307	1	Decal, 360207
260234	1	Seal Kit, 360207
260347	1	Decal, 360211
260238	1	Seal Kit, 360211

Part numbers marked with an asterisk (*) are contained in Seal Kit No. 260234.

Part numbers marked with a (†) are contained in Seal Kit No. 260238

8 Ton (360210) & 30 Ton (360212) Remote Hydraulic Cylinder Parts List

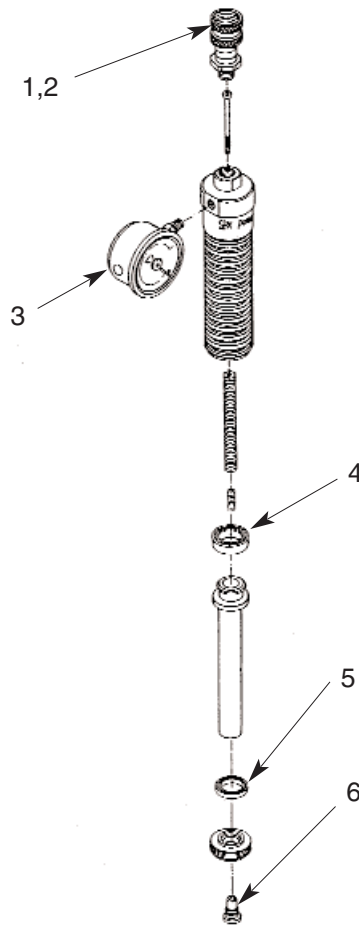

Item No.	Part No.	No. Req'd	Description	Item No.	Part No.	No. Req'd	Description
1	9797	1	Plug, Dust (8 Ton, 30 Ton)	Additional Items (not shown)			
2	25600	1	Coupler, Cylinder Half (8 Ton, 30 Ton)				
3	260284	1	Gauge, 15,000 psi (8 Ton, 30 Ton)	260310	1	Decal, 360210 (8 Ton)	
4	*260252	1	U-Cup, Piston Rod (8 Ton)	260235	1	Seal Kit, 360210 (8 Ton)	
	†260315	1	U-Cup, Piston Rod (30 Ton)	260311	1	Decal, 360212 (30 Ton)	
5	260253	1	U-Cup, Gland Nut (8 Ton)	260239	1	Seal Kit, 360212 (30 Ton)	
	†260316	1	U-Cup, Gland Nut (30 Ton)				
6	*260256	1	Cone Ass'y, Removable (8 Ton)				
	†260317	1	Cone Ass'y, Removable (30 Ton)				

Part numbers marked with an asterisk (*) are contained in Seal Kit No. 260235.
 Part numbers marked with a (†) are contained in Seal Kit No. 260239.

**Internal Puller Parts List
(360209)
PHP8 Series Pusher Only**

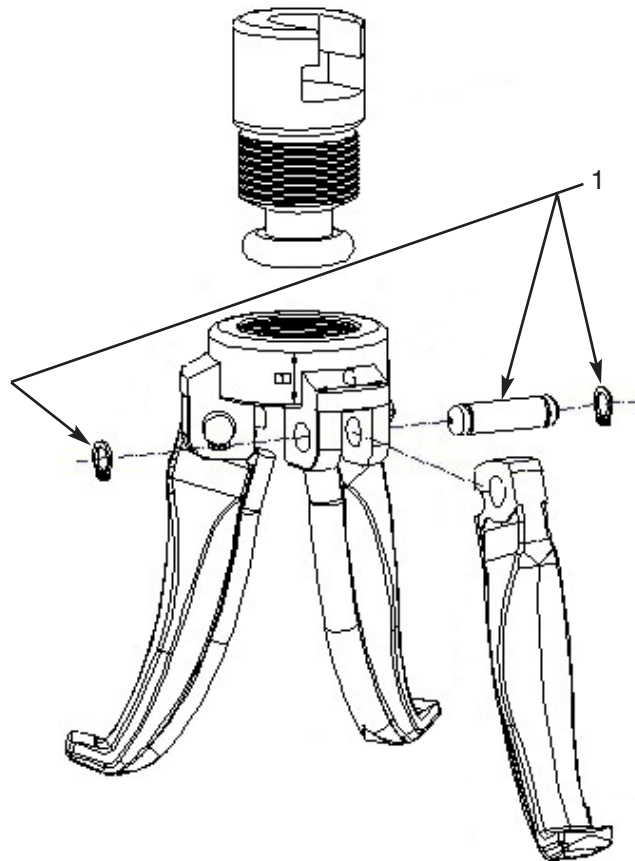

Item No.	Part No.	No. Req'd	Description
1	260270	1	Pin and Ring, Retaining

Part number is contained in a Kit with quantities of 3.

**Tri-section Press Plate
(360208)
PHP8 Series Pusher Only**

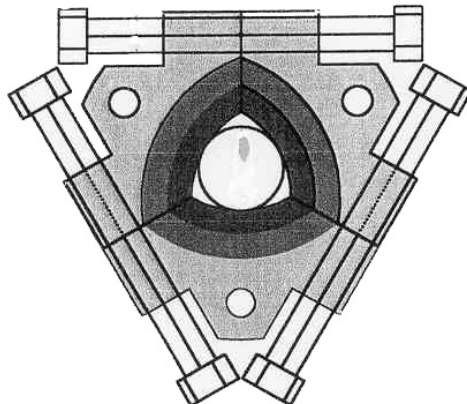

**External Puller Parts List
(260206)
PHP8 Series Pusher Only**

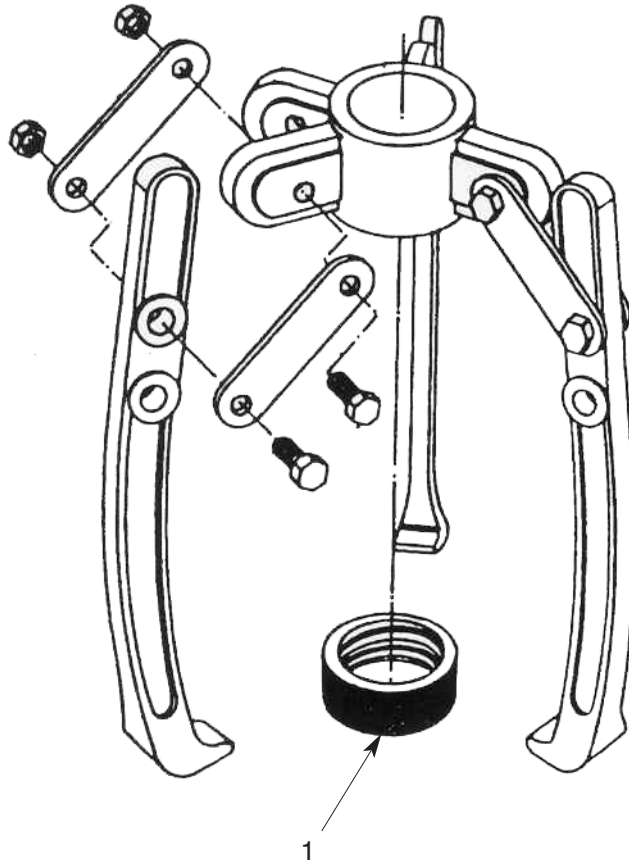

Item No.	Part No.	No. Req'd	Description
1	252898	1	Locknut, Adjusting