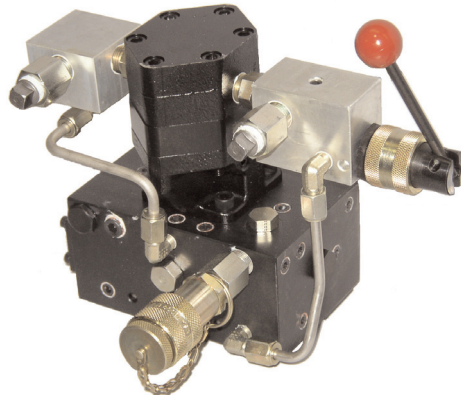

**Operating Instructions and  
Parts List for:****25-OM-10-C  
25-OA-10-C****MODEL 25-OM-10-C & 25-OA-10-C  
HYDRAULIC BOOSTER****INTRODUCTION**

The Hydraulic Boosters are lightweight, high pressure hydraulic boosters of extremely durable construction. It features a built-in pressure operated valve which automatically allows the return of oil from the line when the motor control valve lever is in the "off" position. This unit is designed to operate equipment with single acting spring return cylinders which will withstand pressures to 10,000 PSI. The unit is shipped with the high pressure valve set for 10,000 PSI operation.

The two-speed pump unit consists of a low pressure stage and a high pressure stage. Truck oil which is connected to the in port on the pump, supplies oil for a fast approach. The truck oil also feeds the two high pressure pumps for oil delivery at high pressure.

**IMPORTANT**

The booster is "pressure coded" by means of factory installed quick couplers at tool outlet port. Be sure that any equipment connected to the booster has the adequate **working pressure** rating for the application.

The booster and any connected equipment being driven by this booster is protected by an internal safety relief valve. The care and adjustment of this valve is covered under "Servicing Instructions".

**SPECIFICATIONS**

**HYDRAULIC MOTOR INPUT OIL REQUIREMENTS:**  
2.75 GPM net minimum, 5.50 GPM net maximum flow rate  
1,000 PSI net minimum, 2,000 PSI net maximum pressure

**PUMPING CAPACITY:**  
Low Pressure flow is truck oil bypassed thru pump (approximately)  
High Pressure flow, 50 cu. in. per minute at 10,000 PSI (based on minimum inputs)

**OIL TYPE**  
Mineral based fluids, 180 SSU minimum at 100 degree F, 50 SSU at 210 degrees F minimum for best performance

**WEIGHT:**  
28 lbs. (12.7 kg.) without case, 34 lbs (15.4 kg.) with case

## IMPORTANT SAFETY INFORMATION



This is the safety alert symbol.

It is used to alert you to potential personal injury hazards. Obey all safety messages that follow this symbol to avoid possible injury or death



### DANGER

Denotes an imminently hazardous situation which, if not avoided, will result in death or serious injury.



### WARNING

Denotes a potentially hazardous situation which, if not avoided, could result in death or serious injury.



### CAUTION

Denotes a potentially hazardous situation which, if not avoided, may result in minor or moderate injury.

### CAUTION

Caution used without the safety alert symbol indicates a potentially hazardous situation which, if not avoided, may result in property damage.

### IMPORTANT

Denotes an operating or service procedure or condition considered essential for expedient and efficient operation and service.



### WARNING



It is the operators responsibility to read and understand the following safety statements,

- Only qualified operators should install, operate, adjust, maintain, clean, repair, or transport this machinery.
- Inspect pump before use. Replace any worn or damaged parts. Failure to observe these warning can result in severe injury or death.



### WARNING

• It is important to know maximum pressure ratings of any equipment to which this pump is to be connected, including hoses and fittings. Resetting the relief valve to a pressure higher than these ratings is extremely dangerous and could cause damage or injure personnel.



### WARNING To help prevent personal injury,



- Always wear eye protection whenever operating hydraulic equipment.



- Always wear hearing protection as required.

- Operation, repair, or maintenance of hydraulic equipment should be performed by a qualified person who understands the proper function of hydraulic equipment per local directives and standards.
- Hydraulic equipment must be assembled correctly and then checked for proper function before use. Use hydraulic components of the same hydraulic pressure ratings.



- Never place your hands or other body parts near a hydraulic fluid leak. Never use your hands or other body parts to check for a possible leak.

High pressure fluid can be injected under your skin causing serious injury and/or infection.

- If improperly used, pressurized equipment can be potentially hazardous. Therefore: Hydraulic connections must be securely fastened before building pressure in the system. Release all system pressure before loosening any hydraulic connection in the system.
- Do not exceed the hydraulic pressure rating noted on the booster data plate. Creating pressure beyond the rated pressure can result in personal injury.
- Gauges and accessories may not be included with the booster. However, a hydraulic gauge is strongly recommended whenever the booster is used.

### IMPORTANT

- Properly dispose of all fluids, components, and assemblies at the end of their useful life.
- Hydraulic fluid should be compatible with all hydraulic components.

## OPERATING INSTRUCTIONS

The booster is ready for operation upon leaving the warehouse.

- Locate hole marked "inlet" on front of metal case. Remove metal plug. Connect out-put (pressure) line from supply system.
- Locate hole marked "outlet" on front of metal case. Remove metal plug and connect return (tank) line from supply system.
- Connect the tool line to the proper port equipped with a quick coupler.
- The control lever on the control valve is spring loaded to valve "OFF" position.
- Check tightness of hose connections and be sure quick coupler is completely engaged with coupler on tool line.
- The supply system can now be operated.
- When control lever is pulled back fully to "ON" position, the booster begins to build pressure in the tool line.
- When tool line pressure reaches the relief valve setting, an audible popping will be heard, indicating that no higher pressure can be obtained.
- Move control lever to "OFF" by releasing lever. In "OFF" position, the tool line will automatically exhaust to the supply truck tank.

**The greatest single cause of failure in hydraulic booster is dirt. Extreme caution should be exercised to prevent the introduction of foreign matter into the unit.**

## SERVICING INSTRUCTIONS HIGH PRESSURE VALVE ADJUSTMENT

The high pressure relief valve assembly determines the maximum pressure developed by the booster. The valve is factory set to 10,000 PSI as required.

### IMPORTANT

If by use of a pressure gauge installed in the tool line, it is determined that the pressure setting is incorrect, check tool and all connections for leaks before adjusting valve.

To gain access to the valve, remove pump from the carrying case. Disassemble the valve cover assembly (Key No. 38 & 58) by removing the two flat head screws and cover plate. Insert a #10-32 screw into threaded hole in center of sealing disc and pull disc out of hole in pump block. End of relief valve assembly can now be seen. Remove valve using Power Team Valve removal tool (Part No. 3-4172) available from factory or Power Team distributors. To adjust valve, use a short 5/64 hex socket key to loosen set screw shown on side of valve assembly. To increase pressure, use a screwdriver to turn slotted adjusting screw clockwise deeper into valve body or counter-clockwise out of body to decrease pressure. Pressure will change at a rate of approximately 1,000 PSI per 1/8 turn of adjusting screw. After making adjustment, re-tighten locking set screw securely, re-assemble disc and cover using care not to cut o-ring on disc and re-check pressure as before.

### Compatible Hydraulic Fluids:

The use of Amoco Rykon MV oil is recommended. Compatible fluids include:

Mobil DTE 13  
Mobil ATF 220  
Shell Tellus 32  
Arco Dexron III  
Citgo AW32  
Citgo Dexron III

Other fluids also may be used if they meet or exceed the following specifications:

Viscosity: 180 SSU at 100 degree F.  
Flash Point: 350 degree F  
Pour Point: -50 degree F

---

Sheet No. 2 of 5

---

Rev Date: 09 Feb 2004

---

## PREVENTIVE MAINTENANCE



**WARNING** To help prevent personal injury,

- Disconnect the booster from the supply system before performing maintenance or repair procedures.
- Repairs and maintenance are to be performed in a dust-free area by a qualified technician.

### Maintenance Cleaning

**IMPORTANT**

**Never use a high pressure washer to clean hydraulic components!**

1. Keep the boosters outer surface as free from dirt as possible.
2. Seal all unused couplers with thread protectors.
3. Keep all hose connections free of dirt and grime.
4. Equipment connected to the booster must be kept clean.
5. Use a high grade hydraulic fluid in this booster. Change as recommended (every 300 hours). Some conditions may require the use of different viscosity hydraulic fluids.
6. Check truck reservoir occasionally for possible accumulation of sediment.

## TROUBLE-SHOOTING GUIDE



**WARNING** • To help prevent personal injury, any repair work or trouble-shooting must be done by qualified personnel familiar with this equipment.

- Use the proper gauges and equipment when trouble-shooting.

PROBLEM	SOLUTION
Pump (Oil Motor) does not function	Supply hoses reversed; switch hoses. Couplers not tight, tighten connections
Improper advance of tool piston	<ol style="list-style-type: none"> <li>1. If air in circuit; run pump to work out air.</li> <li>2. Low truck reservoir oil supply; add oil per truck service instructions.</li> <li>3. Truck does not have minimum output. (See Specifications)</li> </ol>
Noise in hydraulic systems	Check and follow 1,2, and 3 above
Tool piston does not retract	Loose quick coupler; tighten all couplers.
Frequent additions of oil required	Check tool and pump for broken lines, loose fittings and connections. Check for Leaks around packing and seals.
Tool piston, slow retraction	Tool retraction mechanism faulty, repair.
Unable to reach pressure	<ol style="list-style-type: none"> <li>1. Same as above.</li> <li>2. Dirt causing valve to stick open; flush out entire system per truck reservoir instructions.</li> <li>3. Pressure operated release valve out of adjustment, re-adjust per "Pressure Operated Valve Adjustment".</li> </ol>
Pressure reached before work is completed	Loss of pressure setting in high pressure relief valve; adjust per "High Pressure Valve Adjustment".

PARTS LIST

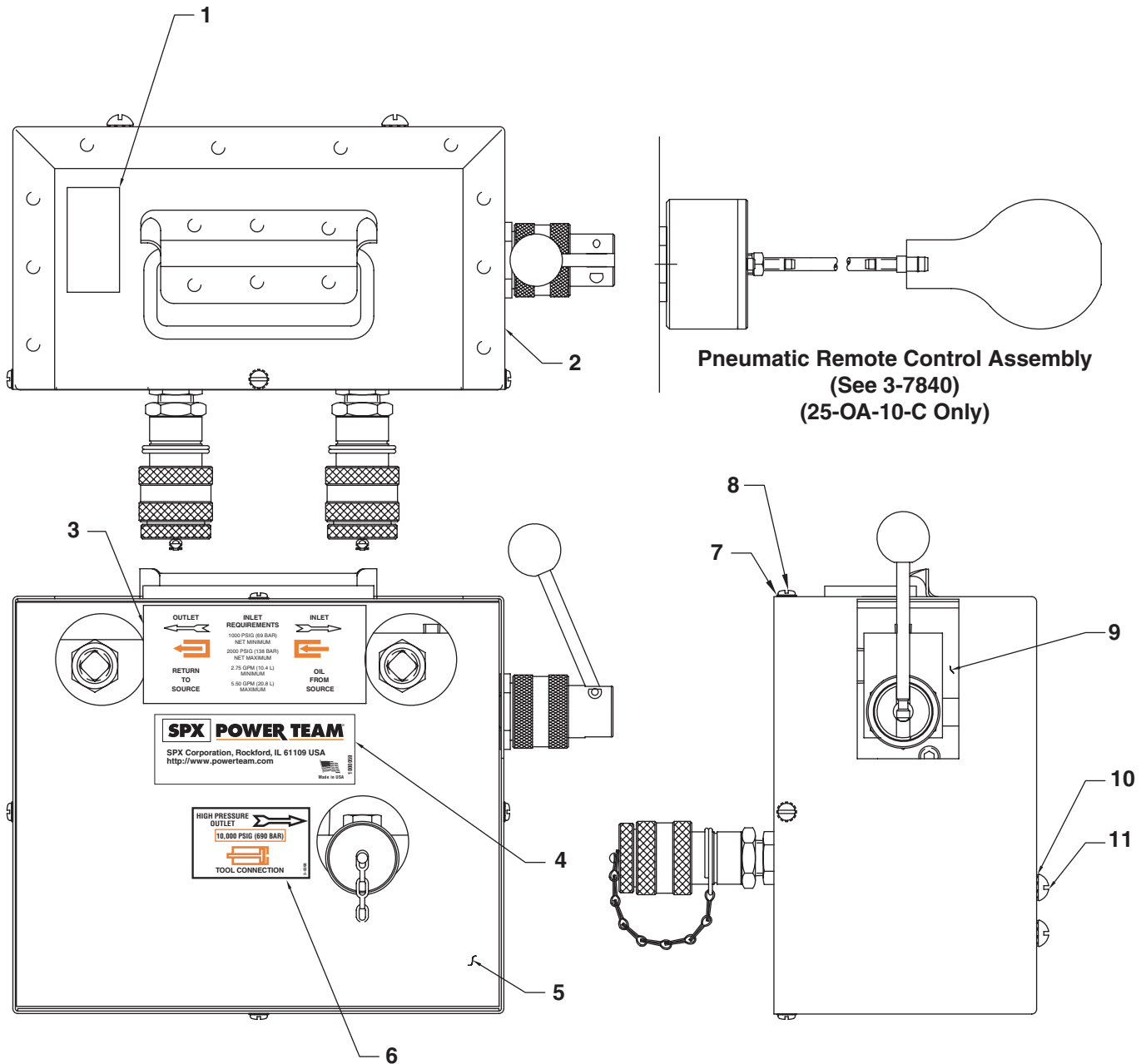

HYDRAULIC POWER PUMP 25-OM-10-C & 25-OA-10-C

Item No.	Part No.	No. Req'd	Description	Item No.	Part No.	No. Req'd	Description
1	420691	1	Decal, Product Blank	7	11388	4	Washer, (Tooth Ext .37 x .17)
2	501071-OR9	1	Case, (25 OM/OA Carrying Orange)	8	5-1400	4	Screw, Pan Head Mach.
3	3-5099	1	Decal, (Truck Oil)	9	501058	1	Booster Assembly (25-OM-10 Only)
4	1000056	1	Decal, (Tradename Power Team)		501063	1	Booster Assembly (25-OA-10 Only)
5	422070-OR9	1	Cover, (25 OM/OA ORANGE)	10	11351	4	Washer, (Tooth Ext .50 x .26)
6	3-5098	1	Decal, (Tool Outlet)	11	10450	4	Screw, Mach. Round Slot Head

**PARTS LIST**

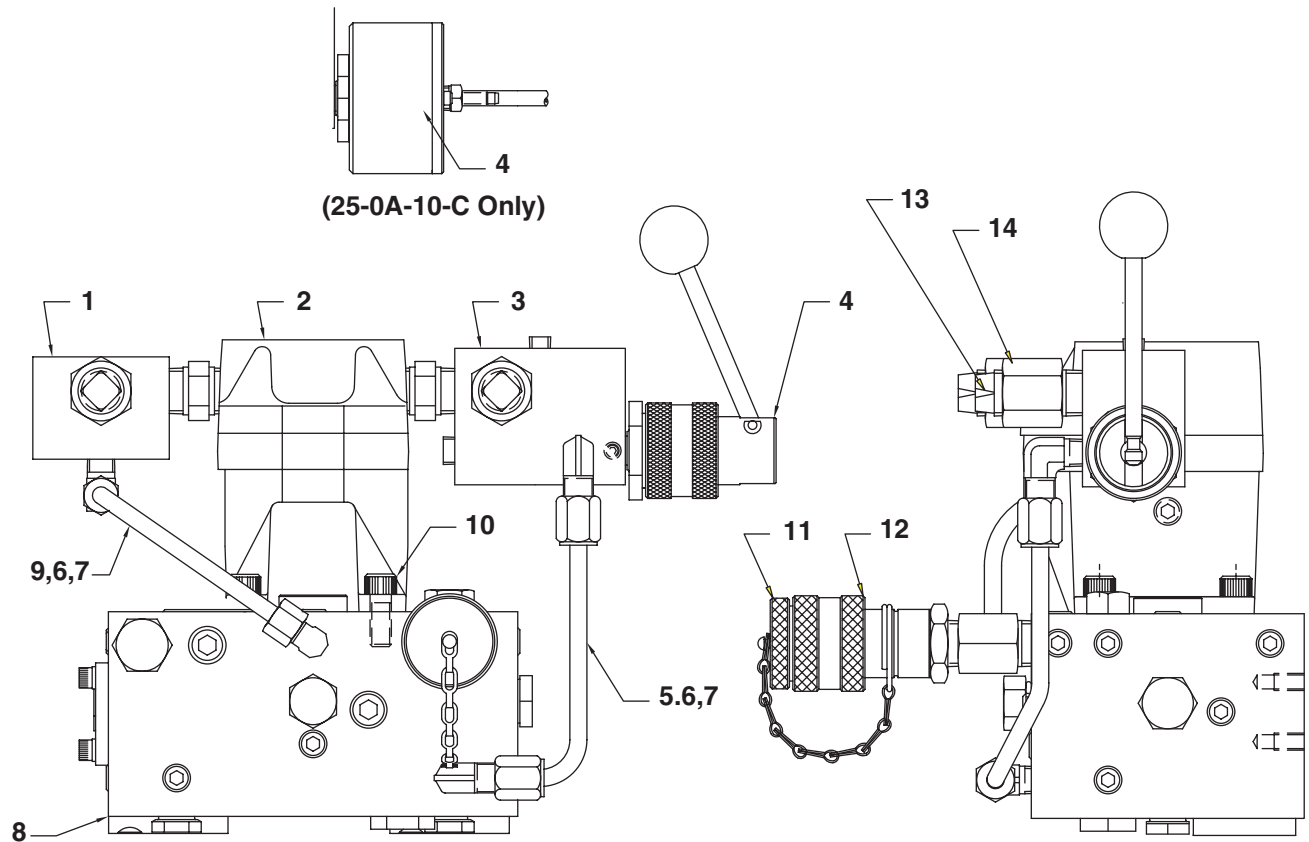

**HYDRAULIC POWER PUMP 25-OM-10-C & 25-OA-10-C**

Item No.	Part No.	No. Req'd	Description	Item No.	Part No.	No. Req'd	Description
1	3-4986	1	Block Assembly, Motor Out	8	3-4983	1	Block Assembly
2	FM-1002	1	Fluid Motor 5.0 cc	9	260087	1	Tube
3	3-7740	1	Valve Assembly, Control	10	10030	1	Screw, Soc.Hd. (5/16-18 x 3/4)
4	3-7750	1	Control Assembly, Manual	11	9797	1	Dust Plug
	3-7840	1	Control Assembly, Remote	12	25600-1	1	Coupler
5	260086	1	Tube	13	11127	2	Plug, Shipping
6	5-0529	4	Nut	14	5-0545	1	Fitting, Aero-Quip No. 2040-6x6
7	5-0530	4	Ferrule				

PARTS LIST

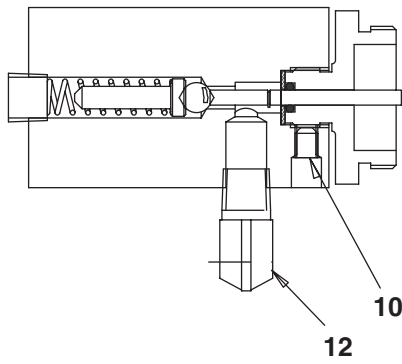
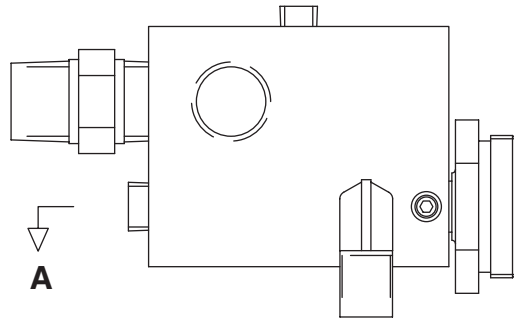

SECTION A-A

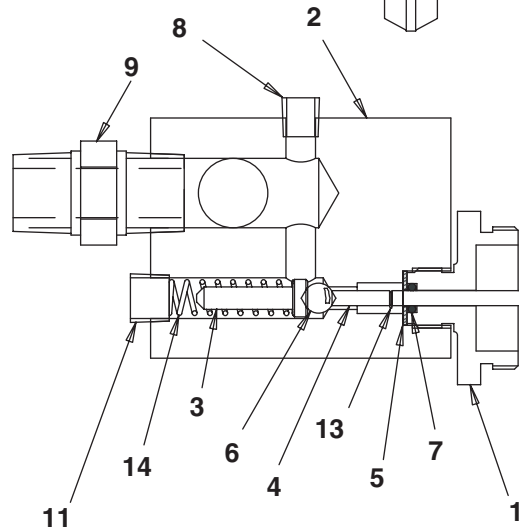
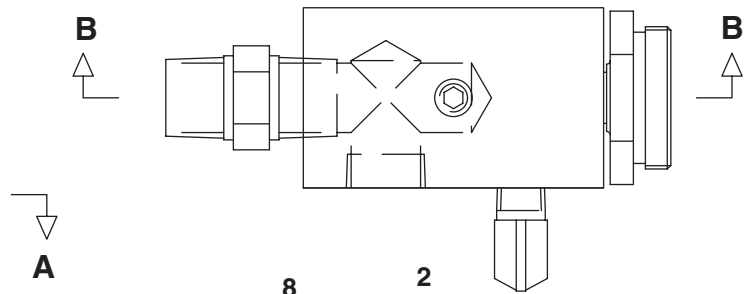

SECTION B-B

VALVE BLOCK ASSEMBLY 3-7740

Item No.	Part No.	No. Req'd	Description
1	3-5593	1	Adapter, Valve Operator
2	3-7741	1	Block, Valve
3	3-7742	1	Plunger, Valve
4	3-7743	1	Rod, Push
5	3-7805	1	Washer, Back-up
6	10375	1	Ball
7	10264	1	O-Ring

Item No.	Part No.	No. Req'd	Description
8	251222	1	Plug, Pipe
9	10673	1	Nipple
10	5-0425	1	Screw
11	5-0829	1	Plug, Pipe
12	5-1873	1	Body, Elbow
13	5-3310	1	Ring, Retaining
14	5-3336	1	Spring, Compression

**Parts List**

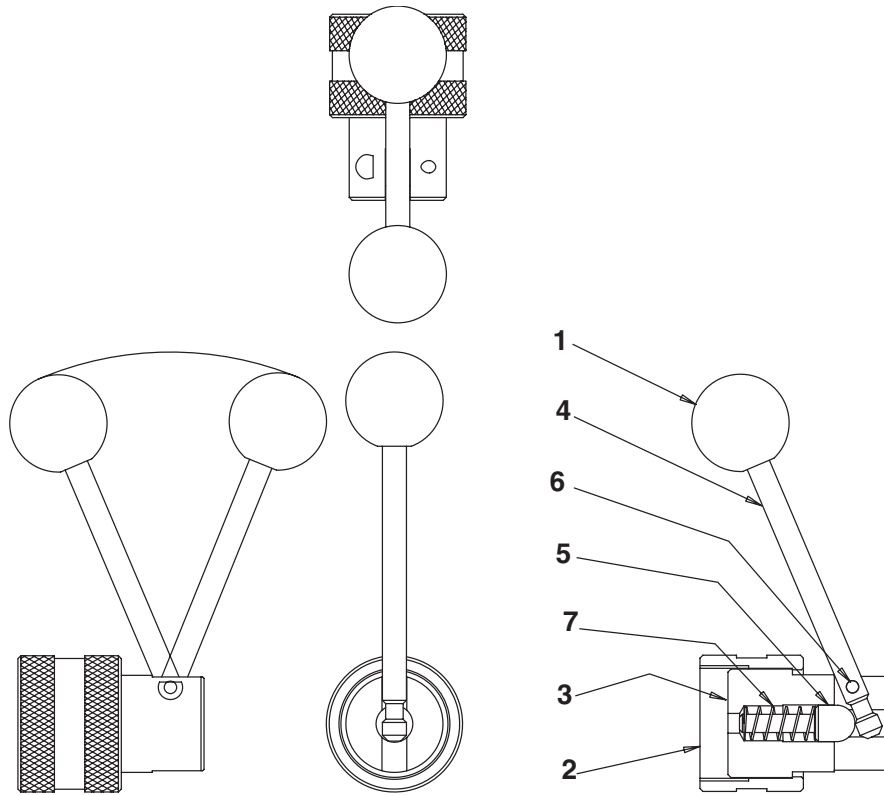

**MANUAL CONTROL ASSEMBLY 3-7750**

Item No.	Part No.	No. Req'd	Description	Item No.	Part No.	No. Req'd	Description
1	3-0016	1	Knob	5	3-7753	1	Plunger
2	3-3983	1	Sleeve	6	5-1268	1	Pin
3	3-7751	1	Housing	7	5-2878	1	Spring
4	3-7752	1	Rod				

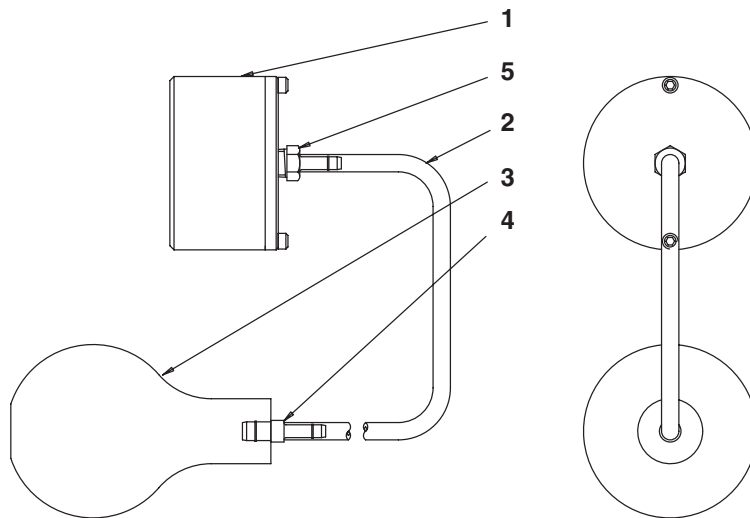

**REMOTE CONTROL ASSEMBLY 3-7840**

Item No.	Part No.	No. Req'd	Description	Item No.	Part No.	No. Req'd	Description
1	3-7746	1	Control Sub Assembly, Air	4	5-0967	1	Connector, Barb
2	5-0016	6 Ft.	Tubing, Nylon	5	5-3369	1	Connector, Threaded
3	5-0965	1	Bulb, Squeeze				



PARTS LIST

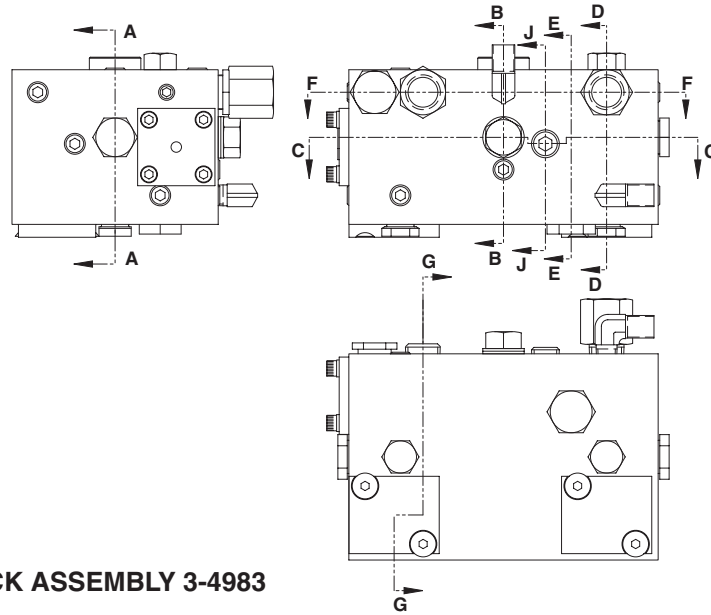

BLOCK ASSEMBLY 3-4983

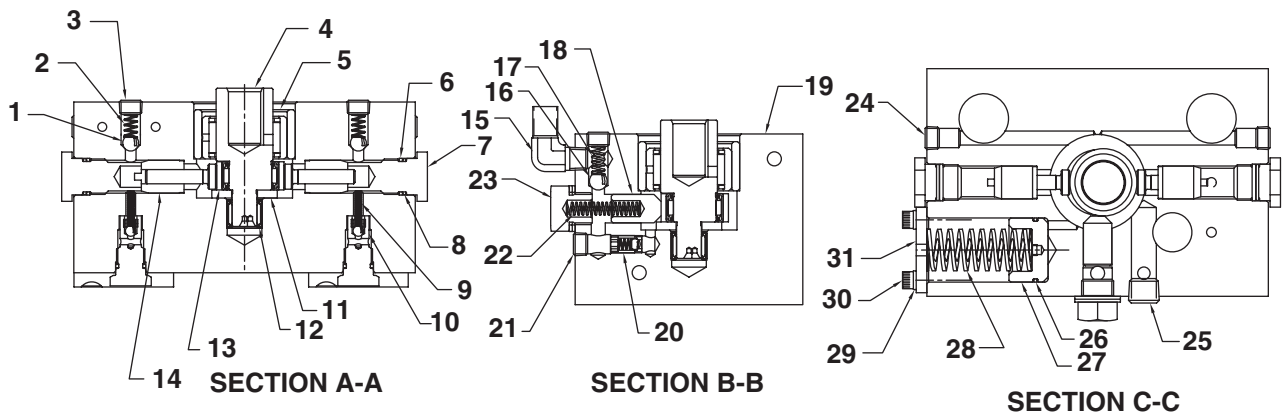

Item No.	Part No.	No. Req'd	Description
1	10423	2	Ball, 9/32" Dia. Steel
2	5-2384	2	Spring, Compression
3	5-0829	2	Plug, Pipe
4	3-3381	1	Shaft, Eccentric
5	3-3400	1	Ring Assembly, Bearing
6	16164	2	O-Ring
7	3-3385	2	Plug, Plunger
8	12390	2	Washer, Back-up
9	5-2064	2	Spring, Compression
10	3-3399	2	Intake Check Assembly
11	3-3383	1	Washer, Thrust
12	5-0141	1	Bearing, Needle
13	3-2445	1	Ring Assembly, Bearing
14	3-2814	2	Plunger Bushing Set
15	5-1873	1	Body, Elbow
16	10377	1	Ball, 5/16" Dia. Steel

Item No.	Part No.	No. Req'd	Description
17	5-1101	1	Spring, Compression
18	3-4990	1	Plunger, Sump Pump
19	3-7939	1	Pump Block
20	3-5308	1	Intake Check Assembly
21	5-0829	1	Plug, Pipe
22	5-1992	1	Spring, Compression
23	11953	1	Plug, Hex
24	5-0829	2	Plug, Pipe
25	10479	1	Fitting, Plug 1/4 NPTF
26	19543	1	O-Ring
27	3-4991	1	Plunger, Accumulator
28	5-2042	1	Spring, Compression
29	10241	4	Lock Washer
30	15122	4	Screw
31	3-4992	1	Cover, Accumulator

Parts List

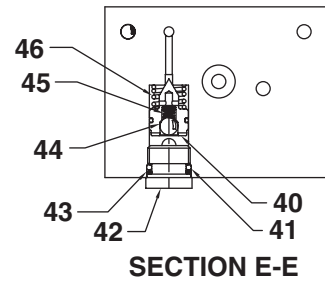
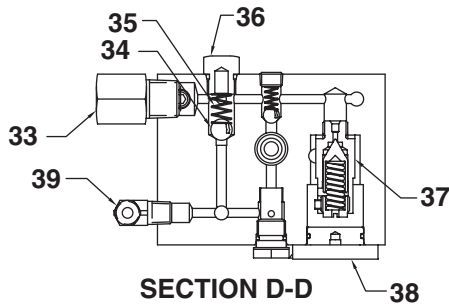

BLOCK ASSEMBLY 3-4983

Item No.	Part No.	No. Req'd	Description
33	5-0545	1	Fitting, Adapter
34	10378	1	Ball
35	5-2905	1	Spring, Compression
36	5-1906	1	Plug, Hex
37	3-2716	1	Valve Assembly 10,000 psi
38	3-3388	1	Cover Assembly, Valve
39	5-1873	1	Body, Elbow

Item No.	Part No.	No. Req'd	Description
40	3-3387	1	Plunger Assembly
41	253035	1	O-Ring
42	3-3386	1	Screw, P.O.
43	5-2155	1	Ring, Back-Up
44	10377	1	Ball
45	5-3041	1	Spring
46	5-3055	1	Spring, Compression

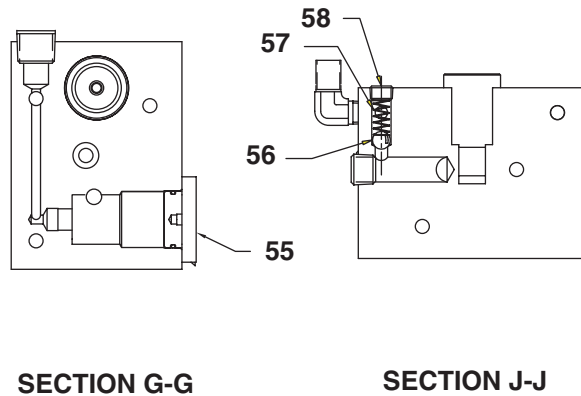
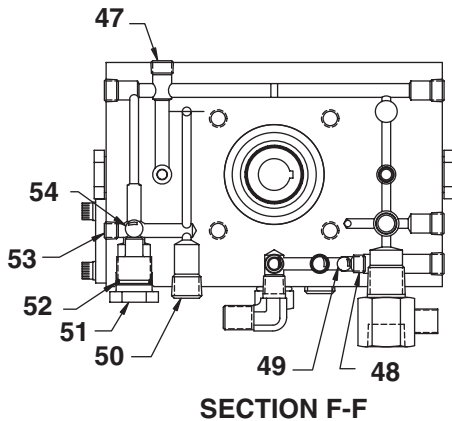

BLOCK ASSEMBLY 3-4983

Item No.	Part No.	No. Req'd	Description
47	5-0829	5	Plug, Pipe
48	5-2901	1	Screw, Set
49	10375	1	Ball
50	10479	1	Fitting, Plug 1/4 NPTF
51	3-3911	1	Plug
52	10301	1	O-Ring

Item No.	Part No.	No. Req'd	Description
53	251222	1	Plug, Pipe
54	10377	1	Ball, 5/16" Dia. Steel
55	3-3388	1	Cover Assembly, Valve
56	10377	1	Ball
57	5-3582	1	Spring, Compression
58	5-0829	1	Plug, Pipe