

## Operating Instructions and Parts List for:

### 100-Ton-S/D-C & 100-Ton-S/D-H-C Hydraulic Compression Tool

## 100-TON-S/D-C & 100-TON-S/D-H-C HYDRAULIC COMPRESSION TOOL



### INTRODUCTION

This portable compressor is designed for the installation of electrical compression fittings either in the shop or in the field. The compressor develops 100 tons of force at 10,200 psi (70.2MPa) operating pressure. The compressor is available with either 100-A or H2H die holders and can be converted from one to the other through use of special kits (See "Parts List"). All procedures described in this manual apply to compressors equipped with either die holder.

### PUMP REQUIREMENTS

Any pump with a fluid reservoir capacity greater than 75 cubic inches and a relief valve setting between 10,000 and 10,400 psi may be used with this compressor.

### HYDRAULIC LINES

Hydraulic lines rated for a minimum of 10,000 psi working pressure must be used regardless of mode of operation (Single or Double Acting)

### COMPRESSOR SPECIFICATIONS

Rated Force ..... 100 Tons (98.2 actual)  
Stroke (with dies) ..... 1.29 inches  
Operating Pressure ..... 10,000 psi  
Type ..... Single/Double Acting

#### Dimensions (with integral ground stand)

Length ..... 12.75 inches  
Width ..... 15.25 inches  
Height ..... 19.75 inches  
Weight ..... 192 lbs. (87.1 kg.) 100-Ton-S/D-H-C  
212 lbs. (96.2 kg.) 100-Ton-S/D-C  
Oil ..... Petroleum based fluid, 180 SSU minimum  
at 100 Degree F. 50 SSU at 210 Degrees F minimum  
for best performance.

## IMPORTANT SAFETY INFORMATION



This is the safety alert symbol.

It is used to alert you to potential personal injury hazards. Obey all safety messages that follow this symbol to avoid possible injury or death



### DANGER

Denotes an imminently hazardous situation which, if not avoided, will result in death or serious injury.



### WARNING

Denotes a potentially hazardous situation which, if not avoided, could result in death or serious injury.



### CAUTION

Denotes a potentially hazardous situation which, if not avoided, may result in minor or moderate injury.

### CAUTION

Caution used without the safety alert symbol indicates a potentially hazardous situation which, if not avoided, may result in property damage.

### IMPORTANT

Denotes an operating or service procedure or condition considered essential for expedient and efficient operation and service.



### WARNING To help prevent personal injury,



- Always wear eye protection whenever operating hydraulic equipment.



- Always wear hearing protection as required.

- Operation, repair, or maintenance of hydraulic equipment should be performed by a qualified person who understands the proper function of hydraulic equipment per local directives and standards.
- Hydraulic equipment must be assembled correctly and then checked for proper function before use. Use hydraulic components of the same hydraulic pressure ratings. An appropriate hydraulic pressure gauge is recommended to monitor pressure.
- Before operating compressor, make sure pull pin assembly is fully engaged and die haves are properly installed.



- Never place your hands or other body parts near a hydraulic fluid leak. Never use your hands or other body parts to check for a possible leak.

High pressure fluid can be injected under your skin causing serious injury and/or infection.



- Exercise caution to avoid the risk of fire. An incomplete crimp can cause a fire. Use proper die, connector and cable. Improper combinations can result in an incomplete crimp.



- This tool is not insulated. When using this unit near energized electrical lines, use proper personal protective equipment.



### CAUTION

- This tool is designed to operate at 10,200 psi. Lower operating pressure will fail to develop the full tonnage required. Higher iterating pressure could cause structural failure and injury to users.
- Do not operate without dies.

### IMPORTANT

- Properly dispose of all fluids, components, and assemblies at the end of their useful life.
- Hydraulic fluid should be compatible with all hydraulic components.



### WARNING



It is the operators responsibility to read and understand the following safety statements,

- Only qualified operators should install, operate, adjust, maintain, clean, repair, or transport this machinery.
- Inspect tool before use. Replace any worn or damaged parts. Failure to observe these warnings can result in severe injury or death.



### WARNING



Keep hands away from connector to be crimped.

## OPERATING INSTRUCTIONS

**! WARNING DO NOT OPERATE THE COMPRESSOR WITHOUT DIES.**

### OPERATING MODES

Through a special piston design, the compressor can be operated in either **single acting** (spring return) or **double action** (hydraulic return) mode. Conversion from single acting to double acting can be accomplished by simply removing the vent plug from the upper (return port, substituting a quick coupler and utilizing a 4-way control valve at the pump.

### SINGLE ACTING

In the single acting mode, the compressor is equipped with one quick coupler installed in the lower (advance) port and a vent plug in the upper (return) port.

One high pressure hydraulic line connects the compressor to the pump and serves as both inlet and return. The pump used with a single acting compressor must be equipped with a two (2) or three (3) way control valve.

### SINGLE ACTING ADVANCE

High pressure hydraulic fluid from the pump enters the compressor through the lower (advance) port and forces the piston up, crimping the compression fitting. Air trapped above the piston is exhausted through the vent.

### SINGLE ACTING RETURN

Hydraulic pressure from the pump is released and the piston is returned to its at-rest position by a return spring built into the compressor. Hydraulic fluid is returned to the pump reservoir through the same line used to advance the compressor

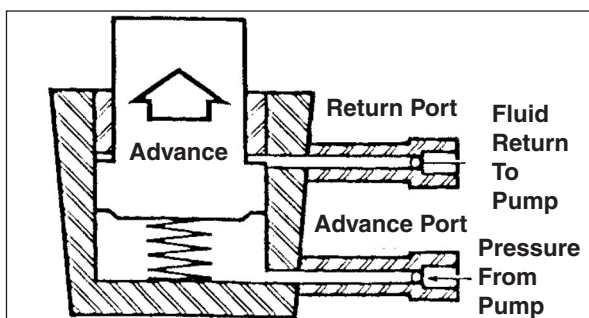
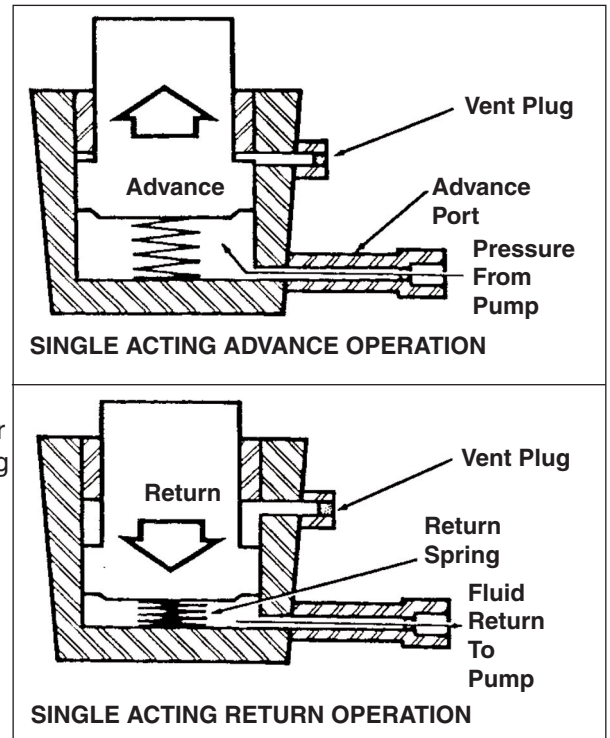

**DOUBLE ACTING ADVANCE OPERATION**

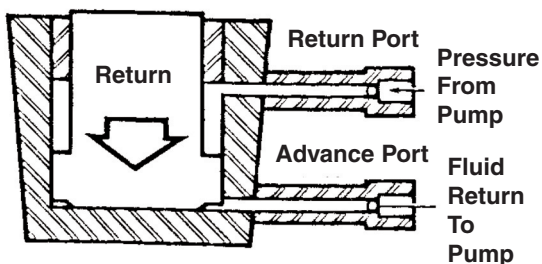

**DOUBLE ACTING RETURN OPERATION**

### DOUBLE ACTING

In double acting operation pressurized hydraulic fluid is used to advance and return the piston resulting in faster cycle times than in single acting operation.

In the double acting mode, the compressor is equipped with quick couplers installed in both the lower (advance) port and the upper (return) port. The high pressure hydraulic lines connect the compressor to the pump.

The pump used with a double acting compressor must be equipped with a 4-way control valve.

### DOUBLE ACTING ADVANCE

As in the single acting mode, high pressure hydraulic fluid from the pump enters the compressor through the lower (advance) port and forces the piston up, crimping the compression fitting. Hydraulic fluid above the piston is returned to the pump reservoir through the upper (return) port.

### DOUBLE ACTING RETURN

High pressure hydraulic fluid from the pump enters the compressor through the upper (return) port and forces the piston down to its at-rest position. Hydraulic fluid below the piston is returned to the pump reservoir through the lower (advance) port of the compressor.

## OPERATING INSTRUCTIONS

### Single Acting Set-Up

Connect one hydraulic line from the lower (advance) port of the compressor to a hydraulic pump equipped with a 2 or 3-way valve. Install vent plug in the upper (return) port

### Double Acting Set-Up

Connect two hydraulic lines from the compressor to hydraulic pump equipped with a 4-way valve. The advance line is connected to the lower (advance) port of the compressor and the return line is connected to the upper (return) port of the compressor.

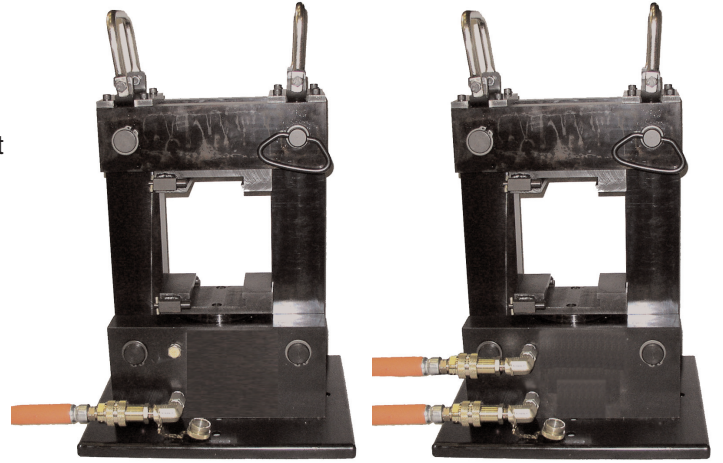

Single Acting Set-Up

Double Acting Set-Up

### Quick Coupler Connection

1. Remove dust covers from couplers.
2. Push male and female halves together at each connection and spin the threaded sleeve of the female half securely onto the threaded portion of the male half. The mating half of quick-coupler supplied with compressor is Power Team Part No. 25599.

**Note:** With connections properly made, ball check valves in both halves of coupler are open to permit free flow of oil in either direction.

### Installing Die Set

1. Select proper die set
2. Push die stop button and slide die half in place
3. Release die stop button and check that die half is securely locked in place.
4. Install remaining die half in same manner.

### Making Compression

1. Withdraw pull pin until pin locks in open position and open compressor
2. Place accessory to be compressed on lower die half
3. Close top of compressor and push pin all the way in until detent is felt
4. Activate pump to close dies. When dies meet compression is complete
5. Shift pump valve to retract lower die. In single acting operation the piston is retracted by the return spring built into the compressor. In double acting operation, the piston is retracted by hydraulic pressure from the pump

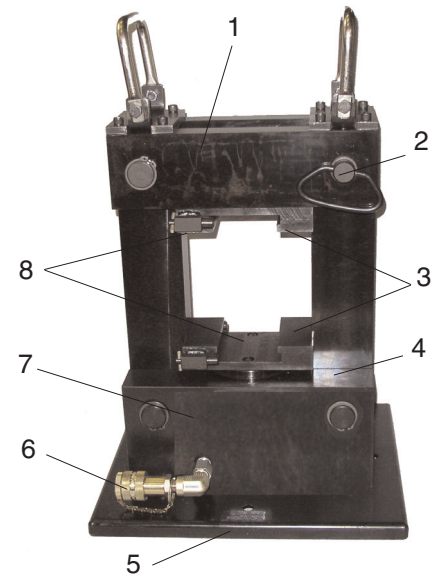

Illustration

- |                             |                     |
|-----------------------------|---------------------|
| 1. Top Die Support Assembly | (Advance Port)      |
| 2. Pull Pin Assembly        | 7. Vent             |
| 3. Die Holders              | (Retract Port)      |
| 4. Side Bar                 | 8. Die Stop Buttons |
| 5. Ground Stand             |                     |
| 6. Coupler, Female          |                     |



**WARNING** Operate compressor only with top support closed and pull pin securely in place

### Die Holder Conversion

Kit No. 3-7211 (100-A Die Holder) or Kit No. 3-6971 (H2H Dies Holder) are available from the factory or authorized service centers.

To replace die holders, withdraw pull pin until it locks in open position. Open compression tool. Remove four capscrews holding die holders in place. Remove old die holders and insert new die holders. Insert new capscrews (provided with kit) and torque to 25-30 ft. lbs. Close compression tool and push pull pin until detent is felt. Compression tool is now ready for die installation.

### Compatible Hydraulic Fluids:

The use of Amoco Rykon MV oil is recommended. Compatible fluids include: Mobil DTE 13 Mobil ATF 220 Shell Tellus 32 Arco Dexron III Citgo AW32 Citgo Dexron III  
Other fluids also may be used if they meet or exceed the following specifications:  
Viscosity: 180 SSU at 100 degree F. Flash Point: 350 degree F Pour Point: -50 degree F

## MAINTENANCE

**Note:** Establish a regular maintenance program to prevent service problems.

1. Clean and inspect compressor after every use.
2. Lubricate moving parts monthly or after every 25 hours of use.
3. Check that pump relief valve pressure is set between 10,000 and 10,400 psi.
4. Check oil level in pump reservoir. Add oil as needed.

**NOTE:** A slight weeping of oil from the ram and pump seals is normal and required to keep moving parts lubricated. Excessive leakage indicates a need for seal replacement.

### Side Bar, Piston Relief and Seal Replacements

Maintenance and repairs of this type should be performed by properly trained personnel in repair shops under clean conditions. In addition to all parts shown on the keyed parts lists, 3-7146 (side bar kit), 3-7133 (piston relief kit) and 3-6702 (seal kit) are available from the factory or an authorized service center.

### Bleeding Compression Tool

Install dies in compression tool. Attach hose(s) from pump to compression tool. Lay compression tool on its side with quick-coupler(s) facing straight up. Position pump above the compression tool. Advance and retract the piston three times. By bleeding the compression tool with this method, air trapped in the compression tool will be transferred to the pump reservoir.

## TROUBLESHOOTING

### Dies Will Not Close

1. Test compressor with substitute pump to determine if problem is in pump or compressor.
2. Check die number to make certain proper size die is being used for accessory being compressed.
3. Check that pump relief valve pressure is set between 10,000 and 10,400 psi.
4. Check for insufficient oil level in pump reservoir

### Lower Die Will Not Retract or Retracts Erratically (Single Acting Operation)

1. Check that quick couplers are securely tightened. If male and female halves are not securely tightened, the ball check valves in the couplers are not forced completely open. In single acting operation the advance pressure from the pump can force oil past these partially open valves, but the force of the piston return springs is not sufficient to force oil back past them to the pump. If this is the case it may be necessary to use pliers or a wrench to close the couplers.
2. Weak or broken return spring.
3. Air in system.
4. Check for excessive oil level in pump reservoir.

### Lower Die Will Not Retract (Double Acting Operation)

1. In double acting operation check that the pump control valve is operating properly; delivering full pressure to the return port of the compressor (1,800 to 2,500 psi)

### Die Will Not Lock Into Position

1. Disassemble, clean and lubricate die retaining unit

### Oil Leaking From Vent Plug (Single Acting Operation)

1. Replace seals. See Parts List

### Oil Leaking From Piston Seal

1. Replace seals. See Parts List

---

Sheet No. 3 of 6

---

Rev Date: 09 Feb 2004

---

**PARTS LIST**

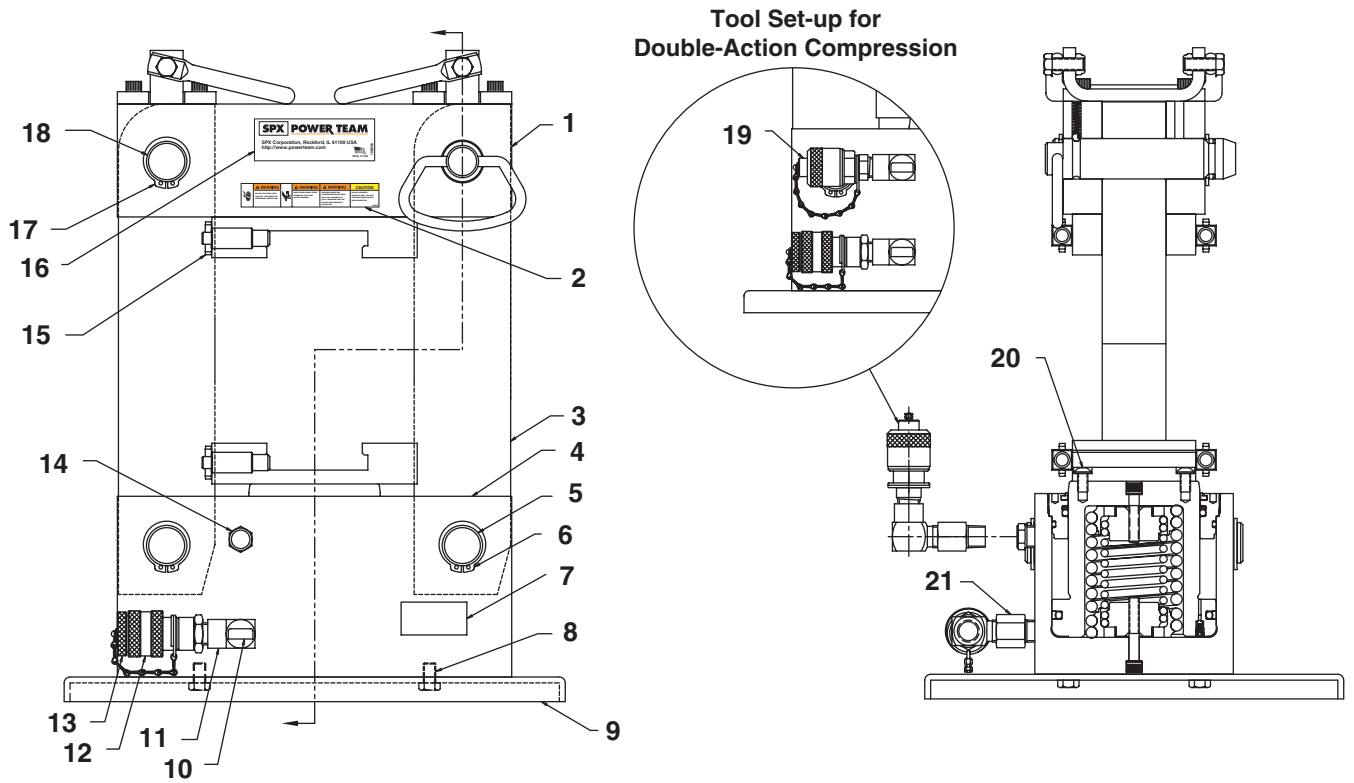

100 Ton Press Assembly - 100 - TON-S/D-C

Item No.	Part No.	No. Req'd	Description	Item No.	Part No.	No. Req'd	Description
1	3-6773	1	Top Support Assembly	15	3-7025	2	Die Holder Assembly (for 100-Ton-S/D-H-C)
2	1000060	1	Decal, Warning		3-6774	1	Die Holder Assembly (for 100-Ton-S/D-H-C)
3	3-6791	2	Bar, Side	16	1000059	1	Decal, Tradename Power Team
4	3-6776	1	Base Assembly	17	5-3083	2	Ring, Retaining
5	3-6789	2	Pin, Bottom Retained	18	3-6790	1	Pin, Top Retained
6	5-3083	4	Ring, Retaining	19	3-9964	1	Coupler Assembly, Male
7	420691	1	Decal, Product Blank	20	5-3136	2	Screw
8	5-0250	4	Screw	21	5-0545	1	Fitting
9	3-0638-BK	2	Base, Black Ground Stand				Item Not Shown
10	3-7342	1	Decal, Advance, Mat. 3-6248				
11	10621	1	Fitting, Elbow 90 Degree 3/8 NPTF				
12	9796	1	Coupler, Female (3/8" NPTF)				
13	9797	1	Plug, Dust				
14	5-3119	1	Breather Vent		3-2842-OR9	1	Case, Carrying

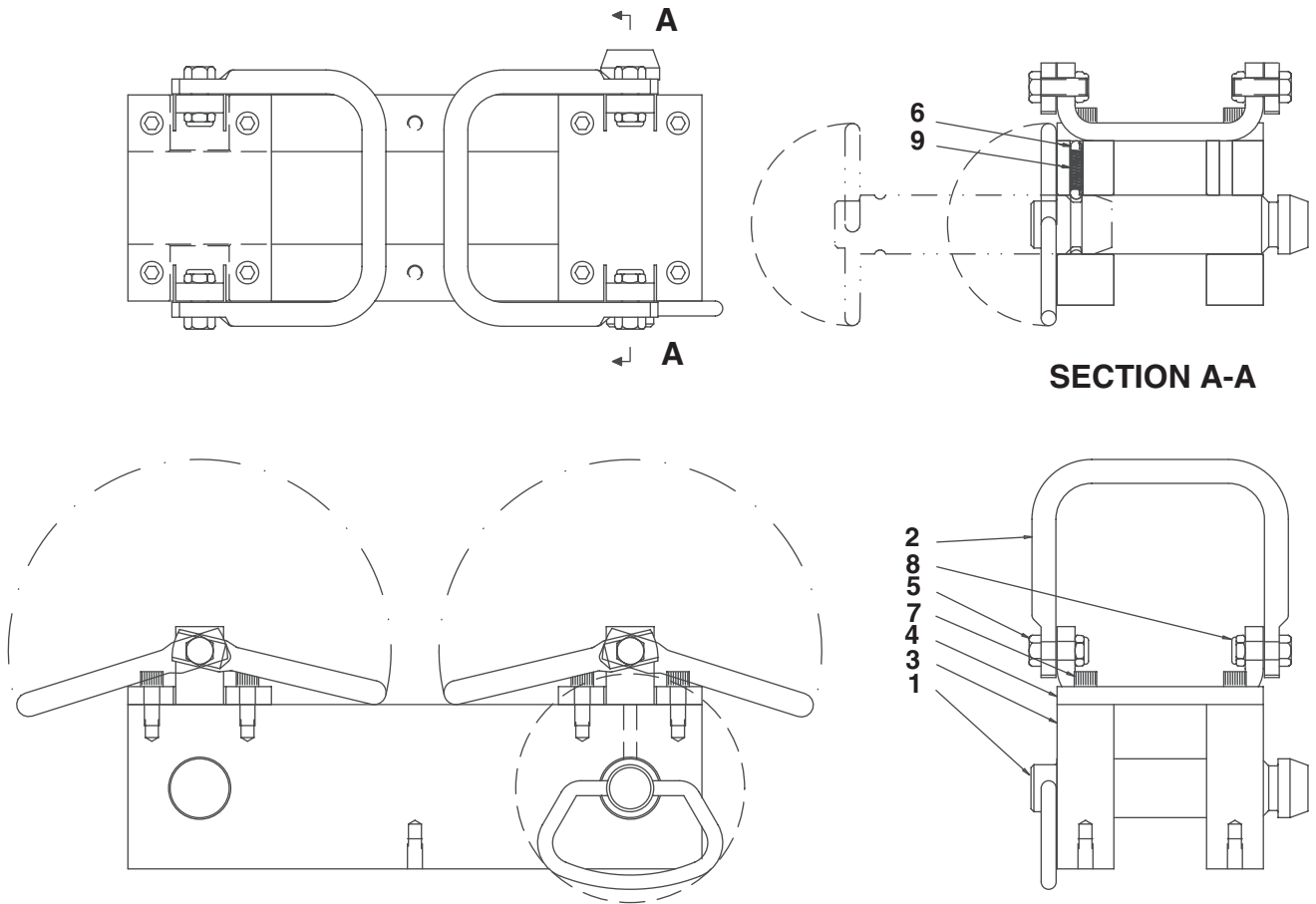

Top Support Assembly - #3-6773

Item No.	Part No.	No. Req'd	Description	Item No.	Part No.	No. Req'd	Description
1	3-6775	1	Pull Pin Assembly	6	10375	2	Ball, (1/4 inch dia. steel)
2	3-6792	2	Handle, Top	7	5-0226	8	Screw, (5/16-24 x 3/4 S.H.C.)
3	3-6794	2	Bar, Top Support	8	5-2755	4	Nut, (3/8-16 Locking)
4	3-6795	2	Plate, Top Support	9	5-3077	1	Spring, Compression
5	16932	4	Screw, (3/8-16 x 1 H.H.C.)				

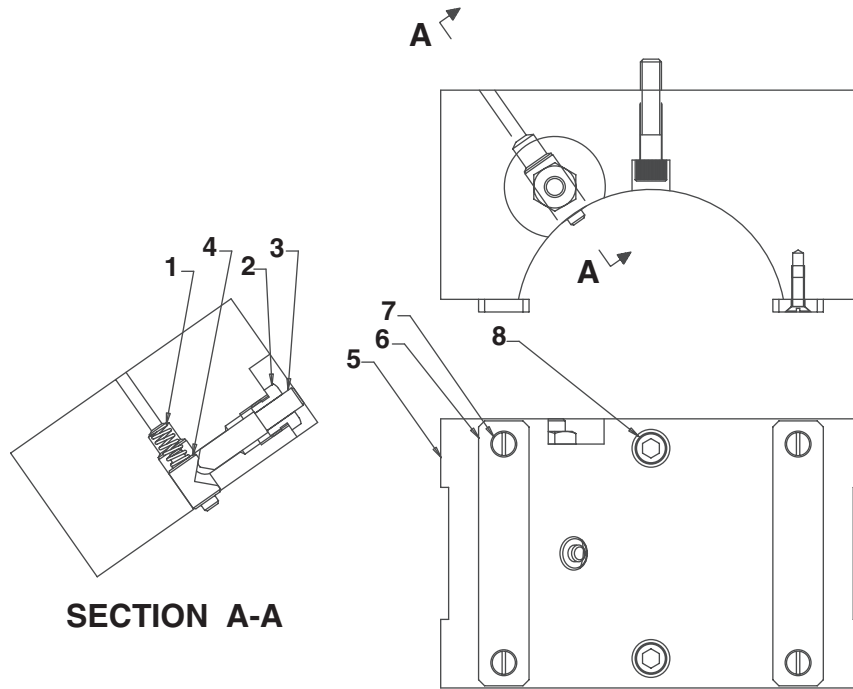

Die Holder Assembly - 3-6774 (For 100-Ton-S/D-C)

Item No.	Part No.	No. Req'd	Description	Item No.	Part No.	No. Req'd	Description
1	3-3710	1	Spring, Compression	5	3-6779	1	Die Holder
2	3-3711	1	Screw, Stop	6	3-6785	2	Retainer, Die
3	3-3712	1	Rod, Push	7	5-0094	4	Screw, (10-32 x 1/2 Ft. Hd.)
4	3-3713	1	Plunger, Die Stop	8	5-0229	2	Screw, (5/16-24 x 2 S.H.)

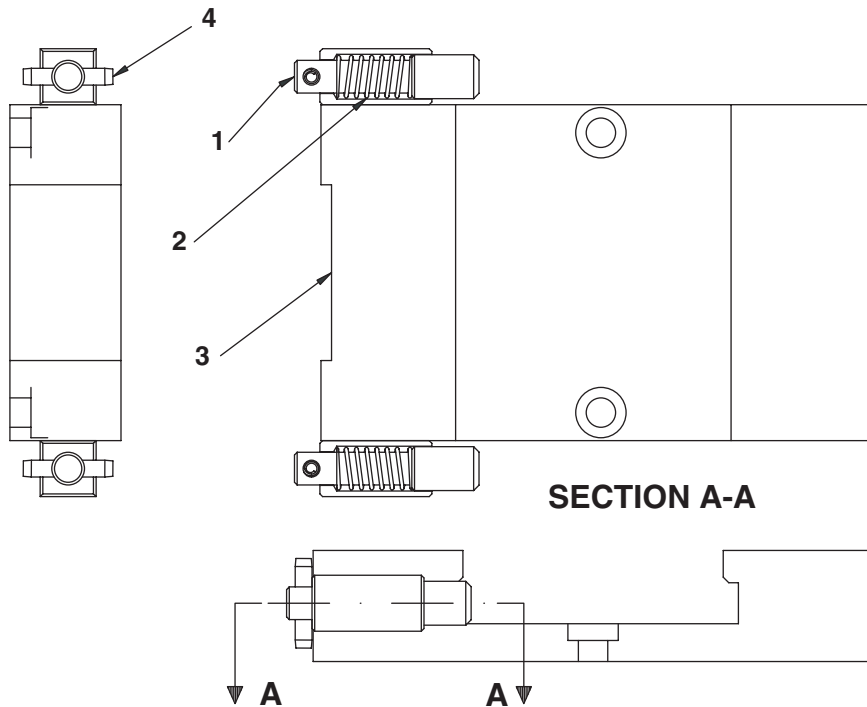

Die Holder Assembly - #3-7025 (For 100-Ton-S/D-H-C)

Item No.	Part No.	No. Req'd	Description	Item No.	Part No.	No. Req'd	Description
1	3-1912	2	Pin, Die Stop	3	3-6970	1	Adapter, Die
2	3-1913	2	Spring, Compression	4	5-0811	2	Pin, (3/16 x 1 Spiral)



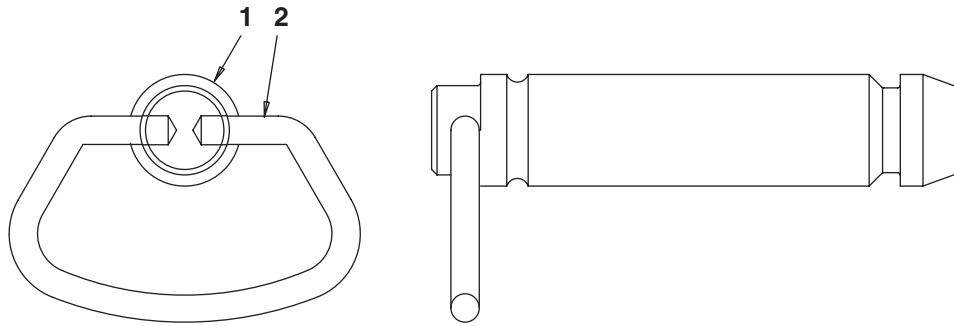

Pull Pin Assembly - #3-6775

Item No.	Part No.	No. Req'd	Description
1	3-6780	1	Pin, Pull

Item No.	Part No.	No. Req'd	Description
2	3-6831	1	Handle

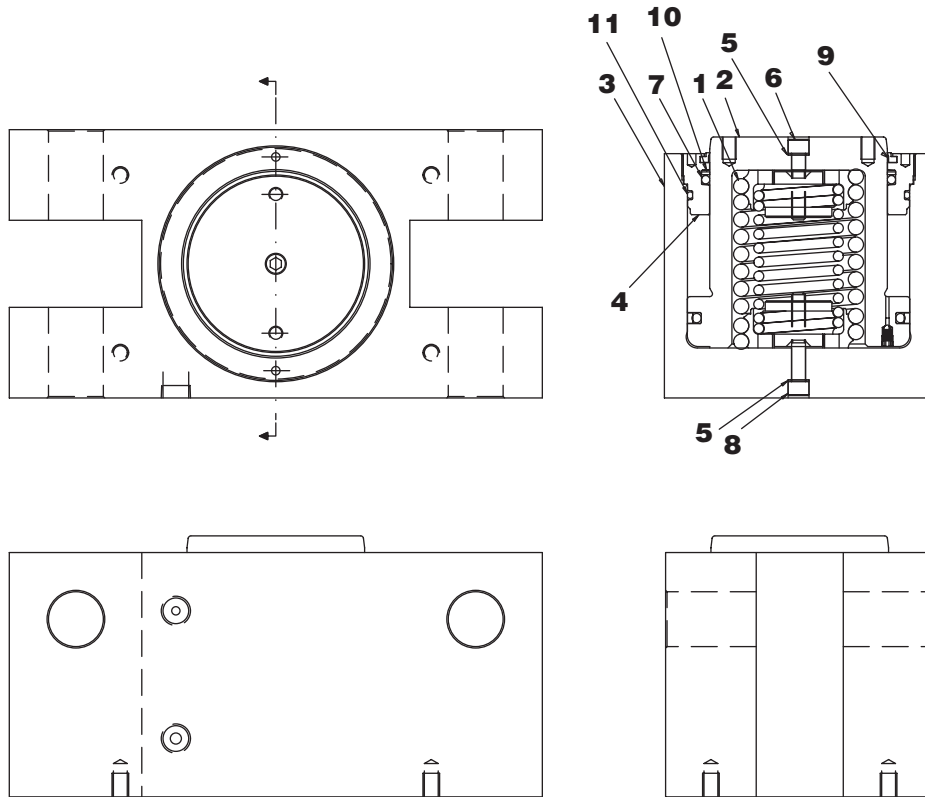

Base Assembly - #3-6776

Item No.	Part No.	No. Req'd	Description
1	3-6777	1	Return Spring Assembly
2	3-6778	1	Piston Assembly
3	3-6786	1	Base
4	3-6787	1	Gland
5	3-6796	2	Washer, Copper
6	5-0229	1	Screw, (5/16-24 x 1-1/2 S.H)

Item No.	Part No.	No. Req'd	Description
7	*5-2096	1	O-Ring
8	251566	1	Screw, (5/16-24 x 2 S.H.C)
9	*214497	1	Wiper, Rod
10	*5-3081	1	Ring, Back-Up
11	*5-3147	1	O-Ring

\* - components of 3-6702 Seal Kit

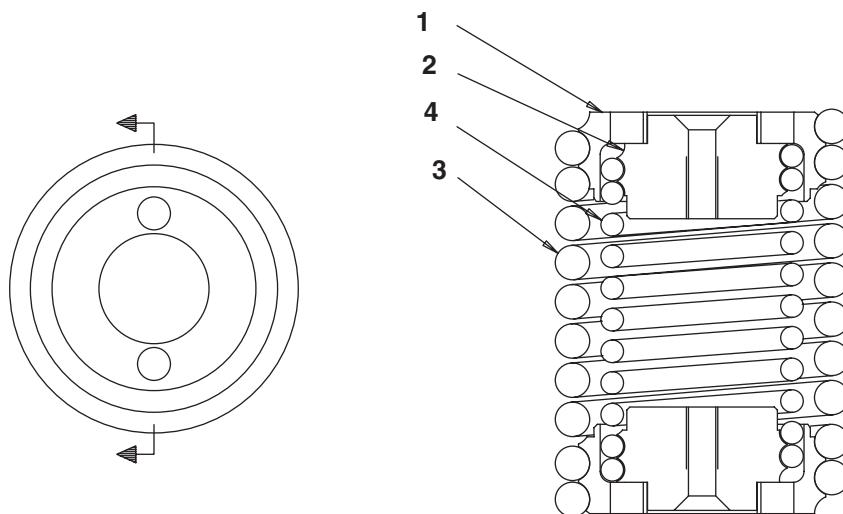

Return Spring Assembly - #3-6777

Item No.	Part No.	No. Req'd	Description
1	3-6781	2	Retainer, Outer
2	3-6782	2	Retainer, Inner

Item No.	Part No.	No. Req'd	Description
3	3-6783	1	Spring, Outer
4	3-6784	1	Spring, Inner

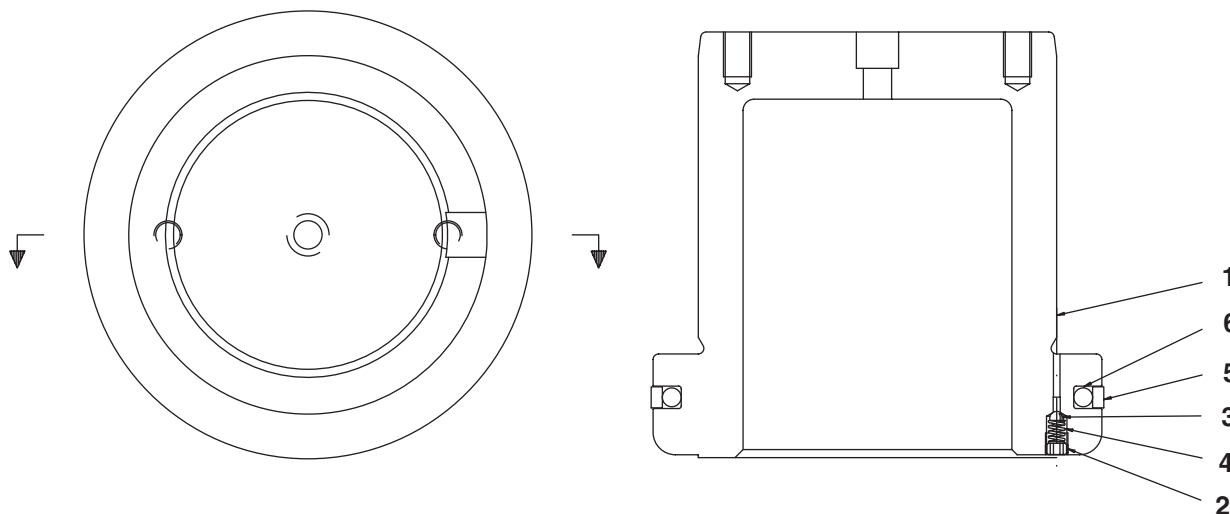

Piston Assembly - #3-6778

Item No.	Part No.	No. Req'd	Description
1	3-6788	1	Piston
2	** 5-2062	1	Screw, (1/4-28 x 1/8 Hol.Set)
3	** 10419	1	Ball, (5/32" Dia. Steel)

Item No.	Part No.	No. Req'd	Description
4	** 5-3041	1	Spring, Compression
5	* 5-3078	1	Seal, Piston
6	* G1-1073-48	1	O-Ring

\* - Components of 3-6702 Seal Kit

\*\* - Components of 3-7133 Piston Relief Kit

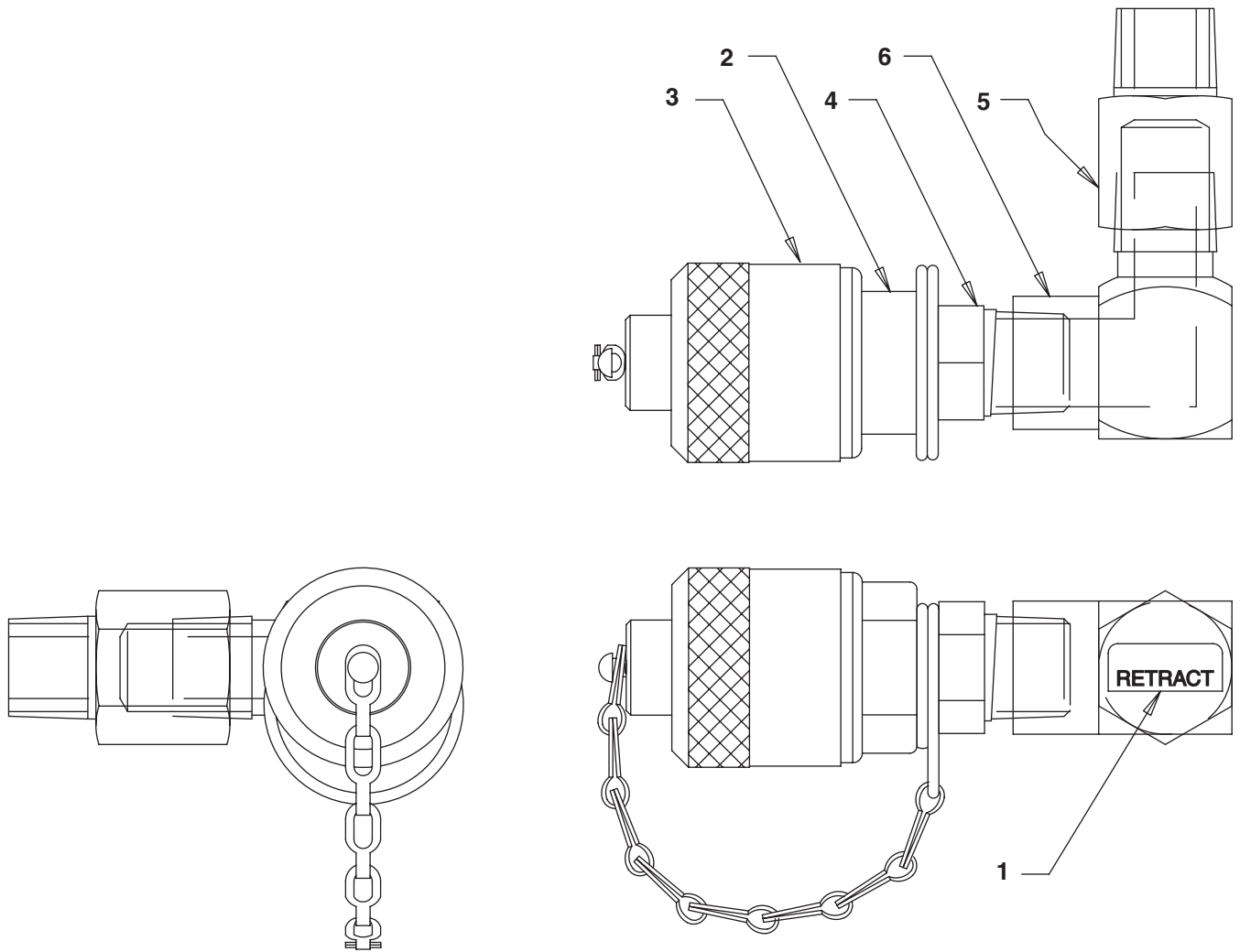

Coupler Assembly - #3-9964

Item No.	Part No.	No. Req'd	Description
1	3-7343	1	Decal, Retract
2	25599	1	Coupler, Hose Half
3	9799	1	Cap, Dust

Item No.	Part No.	No. Req'd	Description
4	10673	1	Fitting, (Straight 3/8 NPTF)
5	5-0545	1	Fitting
6	10621	1	Fitting, (Elbow 90 Degree 3/8 NPTF)