

Model 60-Ton-LS-C HYDRAULIC COMPRESSORS

INTRODUCTION

This portable compressor is designed for the installation of electrical compression fittings either in the shop or in the field. The compressor develops 60 tons of force at 10,200 psi (70.2MPa) operating pressure.

The compressor can be operated in any position. To operate in the air, remove ground stand and suspend press from bail hook.

PUMP REQUIREMENTS

Any pump with a fluid reservoir capacity greater than 50 cubic inches and a relief valve setting between 10,000 and 10,400 psi may be used with this compressor.

HYDRAULIC LINES

Hydraulic lines rated for a minimum of 10,000 psi working pressure must be used regardless of mode of operation (Single or Double Acting).

SPECIFICATIONS

Piston Diameter:

4.00 inches (10.16 cm)

Stroke:

1.31 in. (3.32 cm) with dies

Crimping Force:

62.8 U.S. tons at 10,000 PSI (57.0 Metric tons at 689 BAR)

Crimping Capacity:

Stranded code cable, splices and terminals:

250-2000 MCM (126-1,022 mm²) aluminum300-2000 MCM (151.8-1,012mm²) copper**60-Ton-LS-C WEIGHT**

(with ground stand & oil):

56.5 lbs. (25.63 kg)

QUICK-COUPPLERS:

Pioneer No. 3050-3 female coupler
mates with Pioneer No. 3010-3
male coupler

Oil Type:

Amoco Rykon MV

60-Ton-LS-C Dimensions:

8.5 x 8.96 x 17.54 inches high

(21.59 x 22.76 x 44.55 cm high)



IMPORTANT SAFETY INFORMATION



This is the safety alert symbol.

It is used to alert you to potential personal injury hazards. Obey all safety messages that follow this symbol to avoid possible injury or death



DANGER

Denotes an imminently hazardous situation which, if not avoided, will result in death or serious injury.



WARNING

Denotes a potentially hazardous situation which, if not avoided, could result in death or serious injury.



CAUTION

Denotes a potentially hazardous situation which, if not avoided, may result in minor or moderate injury.

CAUTION

Caution used without the safety alert symbol indicates a potentially hazardous situation which, if not avoided, may result in property damage.

IMPORTANT

Denotes an operating or service procedure or condition considered essential for expedient and efficient operation and service.



WARNING To help prevent personal injury,



- Always wear eye protection whenever operating hydraulic equipment.



- Always wear hearing protection as required.

- Operation, repair, or maintenance of hydraulic equipment should be performed by a qualified person who understands the proper function of hydraulic equipment per local directives and standards.
- Hydraulic equipment must be assembled correctly and then checked for proper function before use. Use hydraulic components of the same hydraulic pressure ratings. An appropriate hydraulic pressure gauge is recommended to monitor pressure.



- Never place your hands or other body parts near a hydraulic fluid leak.
- Never use your hands or other body parts to check for a possible leak.

High pressure fluid can be injected under your skin causing serious injury and/or infection.

- Use proper die, connector and cable. Improper combinations can result in an incomplete crimp.



- DO NOT USE FOR HOT LINE WORK
- This tool is not insulated. When using this unit near energized electrical lines, use proper personal protective equipment.

- This tool is designed to operate at 10,000 psi. Lower operating pressure will fail to develop the full tonnage required. Higher operating pressure could cause structural failure and injury to users.



CAUTION

- Do not advance ram without dies inserted.

IMPORTANT

- Properly dispose of all fluids, components, and assemblies at the end of their useful life.
- Hydraulic fluid should be compatible with all hydraulic components.



WARNING



It is the operators responsibility to read and understand the following safety statements,

- Only qualified operators should install, operate, adjust, maintain, clean, repair, or transport this machinery.
- Inspect tool before use. Replace any worn or damaged parts. Failure to observe these warnings can result in severe injury or death.



WARNING



Keep hands away from the crimping tool head when crimping.

OPERATING INSTRUCTIONS

CAUTION DO NOT OPERATE THE COMPRESSOR WITHOUT DIES.

1. Connect press and hose to pump, making sure quick-couplers are tight. Hose, quick-couplers and pump must be rated for 10,000 PSI (689 BAR) operating pressure.
2. Select proper dies for use on fitting to be compressed. Depress release plunger (3-5575) in top die holder (3-5560) and slide one die half in place. Release plunger and adjust die until it is securely in place. Repeat this step to install bottom die in 3-5559 piston.
3. For the 60-Ton-LS-C, open press by depressing cap locking trigger (3-3587) and rotating 3-3618 cap sub-assembly 90 degrees.
4. Place fitting to be compressed between uprights of cylinder (3-5558) and against bottom die half.
5. Swing cap assembly back into place. Before operating compressor, make sure that head cap is locked in position, die halves are aligned and accessory is properly seated.
6. Run pump to advance piston. When dies meet, compression is complete. Release pressure at pump to allow piston to retract.

NOTES:

The 60-Ton-LS-C can be operated in any position. To operate in the air, remove ground stand and suspend press from bail hook.

PERIODIC MAINTENANCE: Occasionally lubricate release plungers, pivot pins and locking mechanisms to prevent sticking. Use of a molybdenum disulfide grease is recommended.

OIL LEAKAGE: A small amount of weepage from the piston is normal and required to keep moving parts lubricated. Excessive leak ages indicate a need for seal replacement, which should be done only by an authorized service center. Seal kit No. 3-3600 is available for seal replacement.

WARNING

The compressor is designed to operate at 10,500/10,000 PSI (723/689 BAR). Lower operating pressure will fail to develop the full tonnage required. Higher operating pressure could cause structural failure and injury to users.



BLEEDING AIR FROM COMPRESSOR

Remove ground stand from compressor. Install dies in compressor, attach hose and connect to pump. Suspend press, inverted, by the bail hook at a position below the pump. Advance and retract the piston three times.

By filling and bleeding the compressor with this method, air trapped in the compressor will be transferred to the pump reservoir.

PARTS LIST

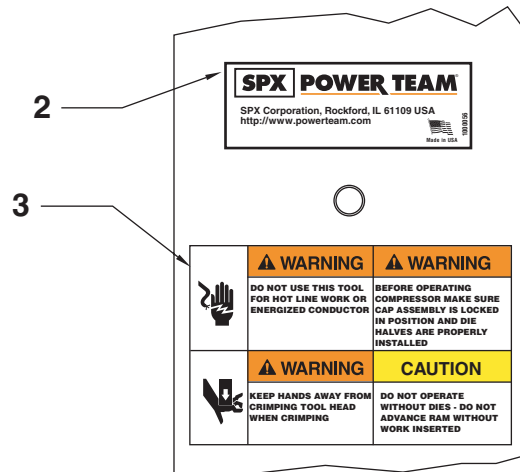
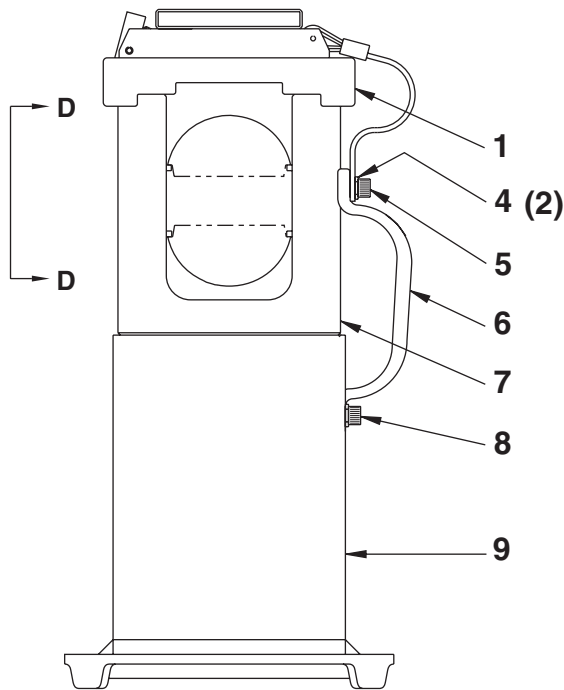

VIEW D-D

Item No.	Part No.	No. Req'd	Description
1	3-3618	1	Cap Assembly
2	1000056	1	Decal, (Tradename PowerTeam)
3	1000119	1	Decal, (Warning)
4	10246	2	Washer
5	210857	1	Screw, SHC

Item No.	Part No.	No. Req'd	Description
6	3-4095	1	Handle
7	3-5558	1	Cylinder, 60-Ton
8	5-0226	1	Screw, SHC
9	2000283BK2	1	Stand, Ground

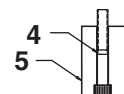
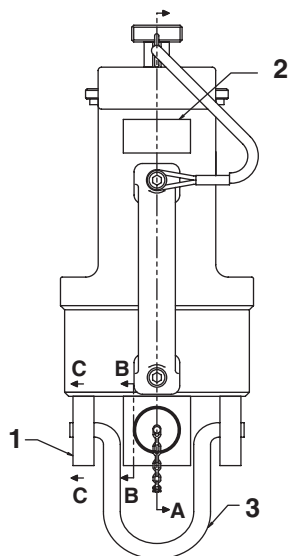

SECTION B-B

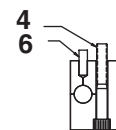

SECTION C-C

Item No.	Part No.	No. Req'd	Description
1	3-5562	1	Hook Pivot Block
2	420691	1	Decal, Product Blank
3	3-3615	1	Hook

Item No.	Part No.	No. Req'd	Description
4	5-0232	4	Screw
5	3-5561	1	Block, Pressure Conn.
6	10716	1	Pin, Roll

PARTS LIST

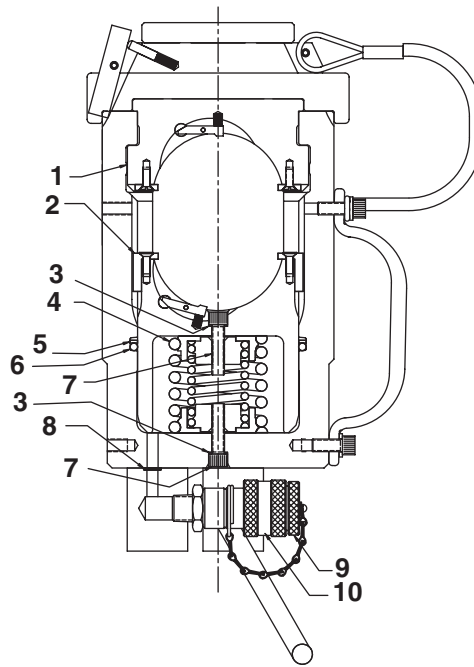

SECTION A-A

Item No.	Part No.	No. Req'd	Description	Item No.	Part No.	No. Req'd	Description
1	3-3631	1	Holder Assembly Top Die	6	5-2096	1	O-Ring
2	3-3572	1	Ram Assembly 60 Ton	7	5-0228	2	Screw, SHC
3	3-6796	2	Washer	8	5-0092	1	O-Ring
4	3-3574	1	Spring Assembly 60 Ton	9	9797	1	Plug, Dust
5	5-2094	1	Ring, Backup	9	9796	1	Coupler, Female

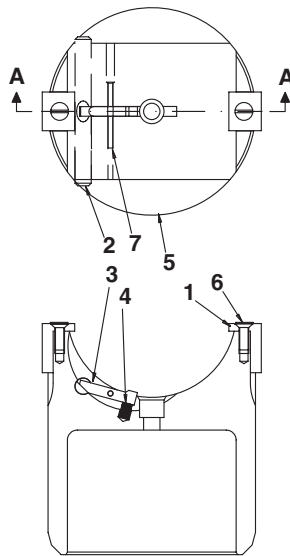

Ram Assembly 3-3572

SECTION A-A

Item No.	Part No.	No. Req'd	Description	Item No.	Part No.	No. Req'd	Description
1	3-2722	2	Retainer, Bottom Die	5	3-5559	1	Body, Ram
2	3-3575	1	Shaft, Release	6	5-0094	2	Screw
3	3-3583	1	Finger, Locking	7	5-2738	1	Pin
4	3-3584	1	Spring, Compression				

PARTS LIST

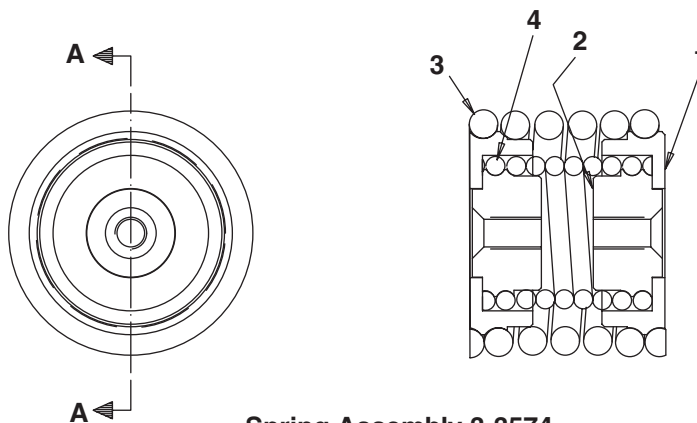

Spring Assembly 3-3574

Item No.	Part No.	No. Req'd	Description	Item No.	Part No.	No. Req'd	Description
1	3-3591	2	Retainer, Outer Spring	3	3-3593	1	Spring, Outer Tension
2	3-3592	2	Retainer, Inner Spring	4	3-3594	1	Spring, Inner Tension

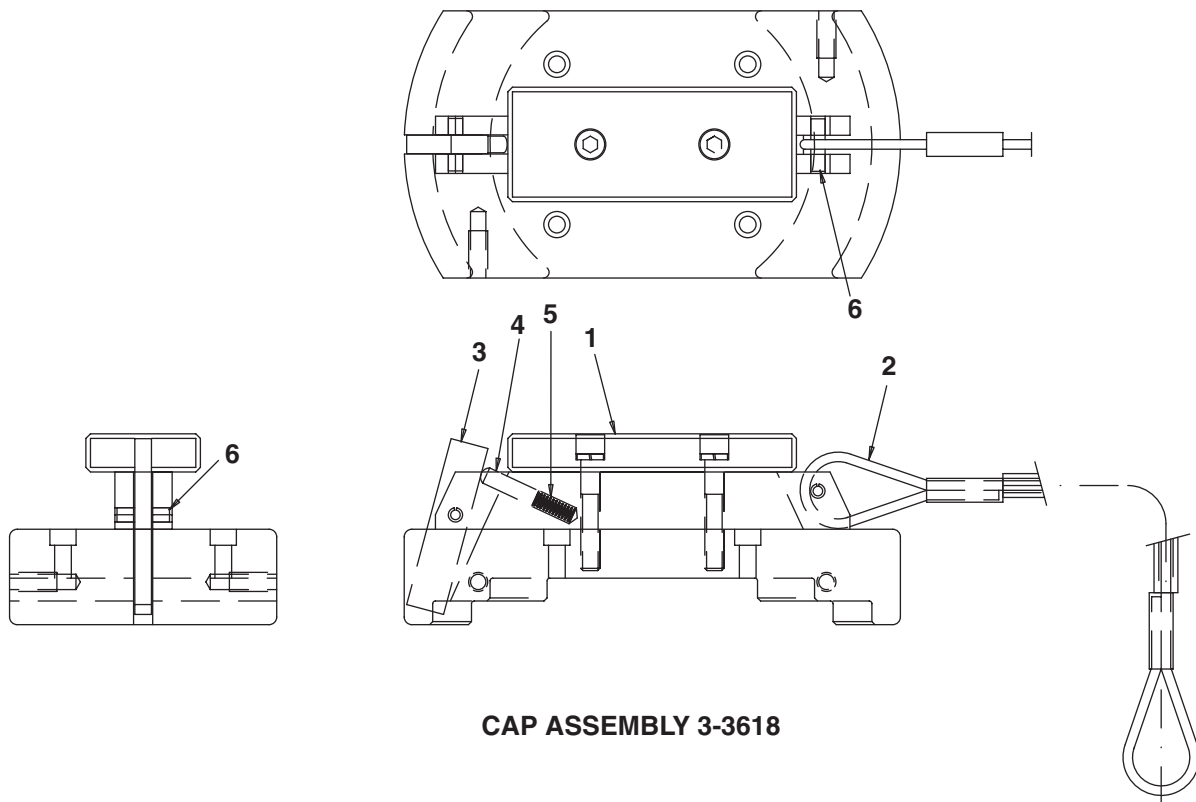

CAP ASSEMBLY 3-3618

Item No.	Part No.	No. Req'd	Description	Item No.	Part No.	No. Req'd	Description
1	3-3609	1	Sub-Assembly, Cap	4	3-3590	1	Plunger, Spring
2	3-2787	1	Cable Assembly	5	3-1369	1	Spring, Compression
3	3-3587	1	Trigger, 60-Ton	6	5-2097	2	Pin, Roll

PARTS LIST

Cap Sub-Assembly 3-3609

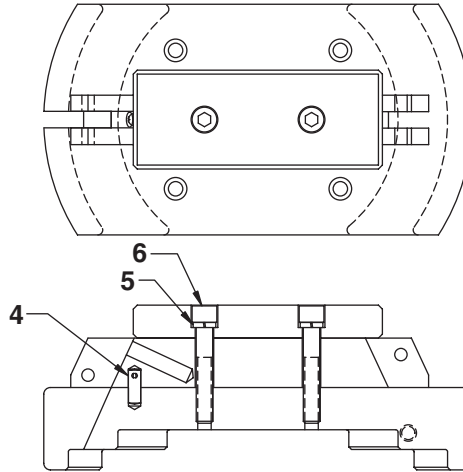
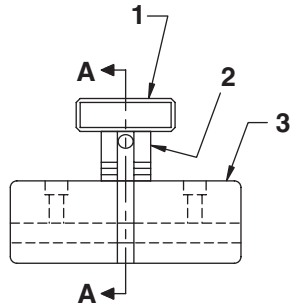

SECTION A-A

Item No.	Part No.	No. Req'd	Description
1	3-6001	1	Handle, Cap
2	3-6002	1	Spacer, Handle
3	3-5555	1	Base, Cap

Item No.	Part No.	No. Req'd	Description
4	5-1604	2	Pin
5	5-1258	1	Lockwasher
6	10022	2	Screw

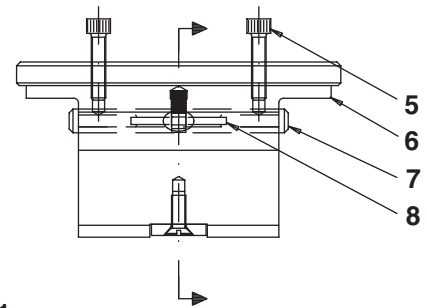
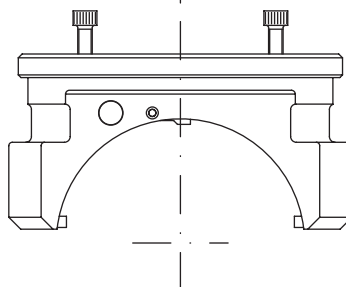
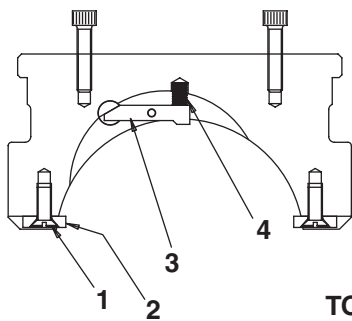
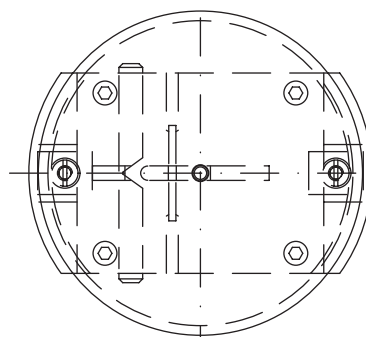

TOP DIE HOLDER ASSEMBLY 3-3631

Item No.	Part No.	No. Req'd	Description
1	5-0094	2	Screw
2	3-2723	2	Retainer, Top Die
3	3-3583	1	Finger, Locking
4	3-3584	1	Spring, Compression

Item No.	Part No.	No. Req'd	Description
5	5-1544	4	Screw
6	3-5560	1	Body, Holder
7	3-3575	1	Shaft, Release
8	5-2738	1	Pin

