

Electric-Powered **PE8 Series Hydraulic Pump**



TABLE OF CONTENTS

DESCRIPTION	2
PE8 Series Electric/Hydraulic Pumps	2
SAFETY SYMBOLS AND DEFINITIONS	3
SAFETY PRECAUTIONS	3
Pump	3
Electric Motor	4
Hoses	4
INITIAL SETUP	5
OPERATING INSTRUCTIONS	11
PERFORMANCE SPECIFICATIONS	16
GENERAL MAINTENANCE	17
TROUBLESHOOTING GUIDE	23
REPAIR PROCEDURES	26
BOLTING SYSTEMS FACILITIES AND CONTACT	27
EC DECLARATION OF CONFIRMITY	28
UKCA DECLARATION OF CONFORMITY	29

DESCRIPTION

PE8 SERIES ELECTRIC/HYDRAULIC PUMPS

Description : The PE8 series hydraulic pumps are designed to have a maximum of 1500 bar (21,750 psi) at a flow rate of 131 cc/min (8 cu. in/min). All pumps come fully assembled, less fluid, and ready for work.

Universal Motor

The universal motor pump shown in Figure 1, is available in a 0.4 kW (1/2 hp). The motor is in single-phase configuration.

The universal motor offers the ability to operate at low voltage. This motor has elevated acoustic output as noted on the product labels. This motor is ideal for long service, fixed applications.

The 0.4 kW (1/2 hp), 110/115 or 220/230 VAC, 50/60 Hz single phase motor starts under load, even at reduced voltage. Current draw can be up to 11 Amps at 115V (15 Amp fuse) and 5.5 Amps at 230V (10 Amp fuse) and the sound level is rated at 82-86 dB. Operating temperatures range is -25°C to +50°C (-13°F to 122°F).

If temperatures are at extremes of the operating range, it is recommended to use hydraulic fluids that are rated for those temperatures. The weight can be up to 50lbs (23kg).



Figure 1. PE8 Series

SAFETY SYMBOLS AND DEFINITIONS

Safety symbols are used to identify any action or lack of action that can cause personal injury. Your reading and understanding of these safety symbols is very important.

 **DANGER** : Danger is used only when your action or lack of action will cause serious human injury or death

 **WARNING** : Warning is used to describe any action or lack of action where a serious injury can occur.

 **CAUTION** : Indicates a potentially hazardous situation which, if not avoided, may result in minor or moderate injury.

CAUTION: Used without the safety alert symbol indicates a potentially hazardous situation which, if not avoided, may result in property damage.

IMPORTANT: Important is used when action or lack of action can cause equipment failure, either immediate or over a long period of time.

SAFETY PRECAUTIONS

 **WARNING** : To prevent personal injury,



- The following procedures must be performed by qualified, trained personnel who are familiar with this equipment. Operators must read and understand all safety precautions and operating instructions included with the device. If the operator cannot read these instructions, operating instructions and safety precautions must be read and discussed in the operator's native language.



- This unit is not suitable for use in explosive environments. Failure to comply may result in damage, injury, or death.



- Safety glasses must be worn at all time by the operator and anyone within sight of the unit. Additional personal protection equipment may include: face shield, goggles, gloves, apron, hard hat, safety shoes, and hearing protection.



- The owner of this tool must verify that safety-related decals are installed, maintained, and replaced if they become hard to read.



- Shut OFF the motor on the connected power unit before opening any connections in the system.

Pump

 **WARNING** : To prevent personal injury,

- Do not exceed the hydraulic pressure rating noted on the pump nameplate or tamper with the internal high pressure relief valve. Creating pressure beyond rated capacities can result in personal injury.
- Retract the system before adding fluid to prevent overflowing the pump reservoir. An overflow can cause personal injury due to excess reservoir pressure created when cylinders are retracted.

Safety Precautions Continued

Electric Motor

⚠ WARNING : To prevent personal injury,



- Electrical work must be performed and tested by a qualified electrician per local directives and standards.
- Disconnect the pump from the power supply and relieve pressure before removing the motor case cover or performing maintenance or repair.
- Check the total amperage draw for the electrical circuit you will be using. *For example: Do not connect a pump that may draw 25 amps to a 20 amp fused electrical circuit.*
- Never use an ungrounded power supply with this unit.
- Changing the voltage is a complex and, if incorrectly performed, hazardous procedure. Consult the manufacturer for specific information before attempting rewiring.



- Wire pump motors for counterclockwise rotation when viewed from the shaft end of the motor.
- Do not attempt to increase the power line capacity by replacing a fuse with another fuse of higher value. Overheating the power line may result in fire.



- Exposing electric pumps to rain or water could result in an electrical hazard.
- Avoid conditions that can cause damage to the power cord, such as abrasion, crushing, sharp cutting edges, or corrosive environment. Damage to the power cord can cause an electrical hazard.

Hoses

⚠ WARNING : To prevent personal injury,



- Before operating the pump, tighten all hose connections using the correct tools. Do not overtighten. Connections should be only secure and leak-free. Overtightening can cause premature thread failure or high pressure fittings to split at pressures lower than their rated capacities.

- Should a hydraulic hose rupture, burst, or need to be disconnected, immediately shut off the pump and shift the control valve twice to release pressure. Never attempt to grasp a leaking hose under pressure with your hands. The force of escaping hydraulic fluid could cause serious injury.
- Do not subject the hose to potential hazard, such as fire, sharp surfaces, heavy impact, or extreme heat or cold. Do not allow the hose to kink, twist, curl, or bend so tightly that the fluid flow within the hose is blocked or reduced. Periodically inspect the hose for wear, because any of these conditions can damage the hose and possibly result in personal injury.
- Do not use the hose to move or carry attached equipment. Physical stress can damage the hose and possibly cause personal injury.



- Hose material and coupler seals must be compatible with the hydraulic fluid used. Hoses also must not come in contact with corrosive material such as creosote-impregnated objects and some paints. Consult the manufacturer before painting a hose. Never paint the couplers. Hose deterioration due to corrosive materials may result in personal injury.

INITIAL SETUP

1. Remove all packing materials from the assembled unit.
2. Inspect the unit upon arrival. The carrier, not the manufacturer, is responsible for any damage resulting from shipment.

Filling the Pump Reservoir

Most pumps are shipped without hydraulic fluid in the reservoir. Hydraulic fluid may have been shipped in a separate container, but if hydraulic fluid is needed, use only approved Power Team hydraulic fluid rated at AW 46 47 cSt @ 38°C (237 SUS @ 100°F). If low temperature requirements are needed, use hydraulic fluid 5.1 cSt @ 100°C (451 cSt @ -40°C).

1. Clean the area around the filler cap to remove debris. Debris in the hydraulic fluid can damage the polished surfaces and precision-fit components of this pump.
2. Remove the filler cap and insert a clean funnel with a filter.
3. Fill the reservoir with hydraulic fluid to 2.6 cm (1 in.) from the cover plate.
4. Replace the filler cap. Verify the breather-hole is open, if applicable.

Hydraulic Connections

1. Clean the areas around the fluid ports of the pump and cylinders.
2. Inspect all threads and fittings for signs of wear or damage, replace as needed.
3. Clean all hose ends, couplers or union ends.
4. Remove the dust cap from the hydraulic fluid outlets.
5. Connect the hose assembly to the hydraulic fluid outlet, and couple the hose to the cylinder.

 **CAUTION** : To prevent personal injury from leaking hydraulic fluid, seal all hydraulic connections with a high-quality, non-hardening, pipe thread sealant.



IMPORTANT: Sealant tape or non hardening sealer tape can be used to seal hydraulic connections if only one layer of tape is used. Apply tape carefully, two threads back, to prevent it from being pinched by the coupler and broken off inside the system. Loose pieces of sealant could travel through the system and obstruct the flow of fluid or cause jamming of precision-fit parts.

Electric Motor Operation

 **WARNING** : Electrical work must be performed and tested by a qualified electrician per local directives and standards.

The electric motor is wired for nominal 115 or nominal 230 volts, 50/60 Hz. Nominal 230 volt electric motors are shipped without a plug attached. Please obtain and install the applicable plug for your area.

Initial Setup Continued

1. See Figure 2. Verify the system pressure manual release valve is in the hold (lever towards the motor) position.

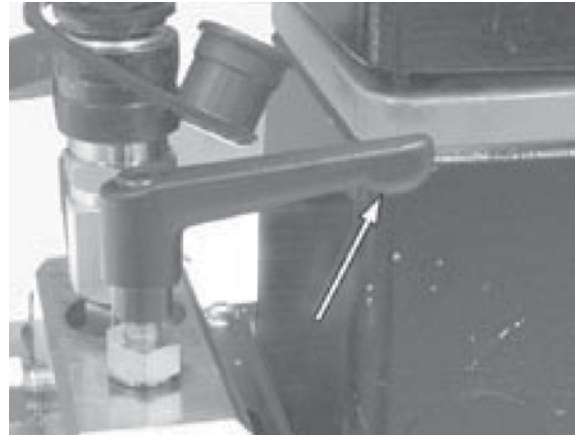
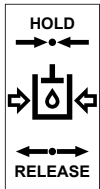

Figure 2. Hold Position

2. See Figure 3. Connect the power cord to an appropriate power source.



Figure 3. Connected to a Power Source

CAUTION

- The correct voltage is required for the pump to operate. Verify the voltage rating on the pump motor name plate matches the outlet or power source you are using. Low voltage may cause: an overheated motor; a motor that fails to start under load; motor surging when trying to start; or a stalled motor before maximum pressure is reached.
- Check the voltage at the motor with the pump running at full pressure.
- Never run the motor on long, light gauge extension cords. Refer to Table 2. Minimum Recommended Gauge Table.

AMPS at Maximum Hyd. Pressure	Electrical Cord Size AWG (mm ²) 3.2 Volt Drop Length of Electrical Cord							
	mm ²				AWG			
	0-8 m	8-15 m	15-30 m	30-46 m	0-25 ft	25-50 ft	50-100 ft	100-150 ft
6	0.75	1	1.5	2.5	18	16	14	12
10	0.75	1.5	2.5	4	18	14	12	10
14	1	2.5	4	6	16	12	10	8
18	1.5	2.5	6	6	14	12	8	8
22	1.5	4	6	10	14	10	8	6
26	2.5	4	6	10	12	10	8	6
30	2.5	4	10	16	12	10	6	4

Table 2. Minimum Recommended Gauge Table

Initial Setup Continued

- See Figure 4. Press the START (green) switch. Lamp (white) will illuminate and power is supplied to the pendant.

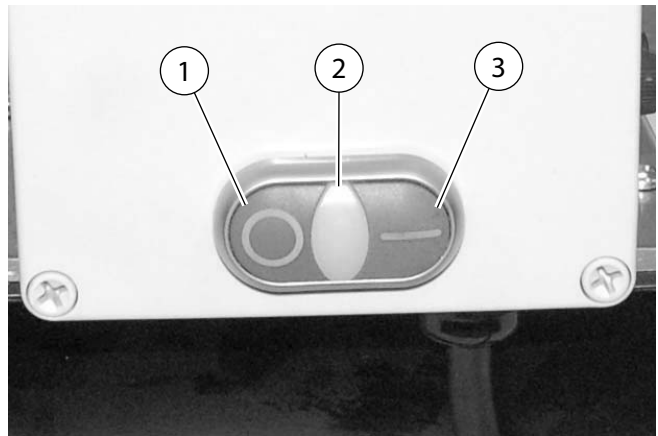

Item	Description
1	Stop (Red)
2	Lamp (White)
3	Start (Green)

Figure 4. Power Switch

- See Figure 5. Using the pendant, press the POWER rocker switch to ON.



Figure 5. Power ON

- See Figure 6. Press and hold the PUMP RUN switch. The pendant will start and run the pump motor as long as the pump run switch is pressed. Switch will automatically return to OFF position when switch is released and pump motor will turn off.

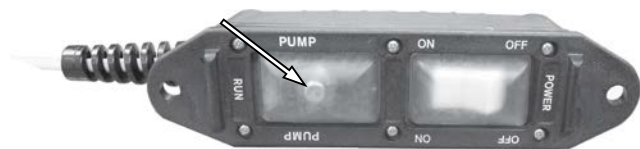
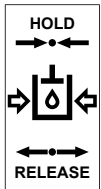

Figure 6. Pump RUN

- See Figure 4. Press the STOP (red) switch to remove power from the pendant.

Initial Setup Continued

7. See Figure 7. To release the pressure, rotate the system pressure manual release valve to the release (lever away from the motor) position.



NOTE: Pressure is retained until it is released with the system pressure release valve lever.

8. See Figure 8. Disconnect the power cord.



Figure 7. Release Position



Figure 8. Disconnected from Power Source

Bleeding Air from the System

1. Cycle the hydraulic system until operation is smooth and consistent.
2. Check the pump reservoir level. Add Power Team hydraulic fluid or equivalent as needed.

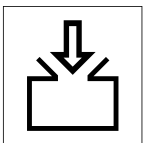

Air can accumulate in the hydraulic system during the initial set-up or after prolonged use causing the tool to respond slowly or in an unstable manner. To remove the air:

3. See Figure 9. Open the filler cap two full turns.



Figure 9. Filler Cap

Initial Setup Continued

4. See Figure 10. Place the system pressure manual release valve in the hold (lever towards the motor) position.

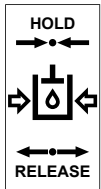

5. Make the necessary hydraulic system connections.

6. See Figure 11. Connect the power cord to an appropriate power source.

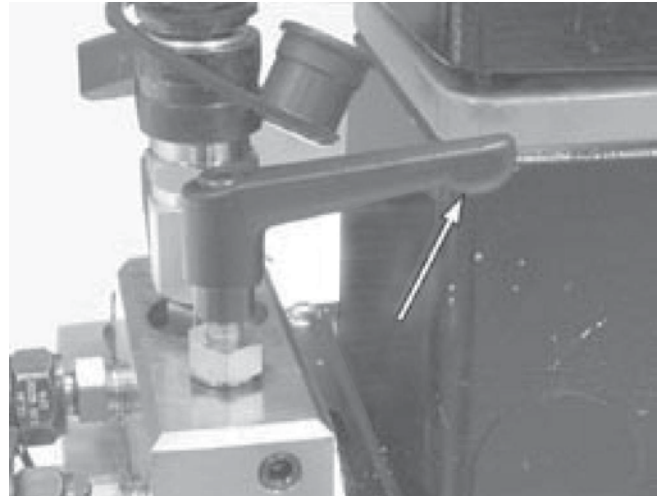
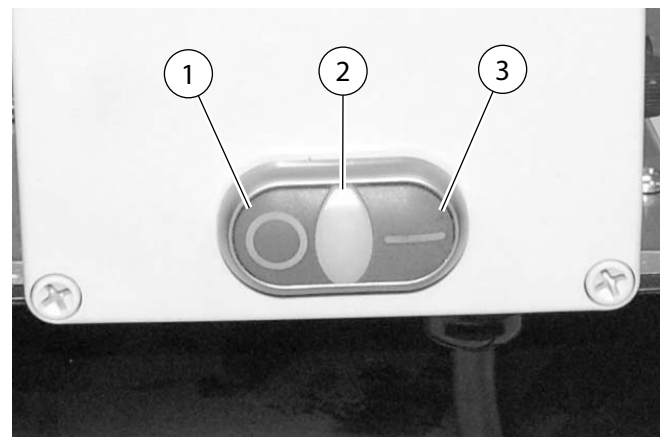

Figure 10. Hold Position



Figure 11. Connected to Power Source

7. Refer to Figure 12. Press the START (green) rocker switch. Lamp (white) will illuminate and power is supplied to the pendant.



Item	Description
1	Stop (Red)
2	Lamp (White)
3	Start (Green)

Figure 12. Power Switch

8. See Figure 13. Using the pendant, press the POWER rocker switch to ON.



Figure 13. Power ON

Initial Setup Continued

9. See Figure 14. Using the pendant, press and quickly release the pump run switch to run the motor for about 0.5 second at a time approximately 5-6 times or until the gauge pressure builds pressure consistently.



Figure 14. Pump RUN

10. See Figure 15. To release the pressure, rotate the system pressure manual release valve to the release (lever away from the motor) position.

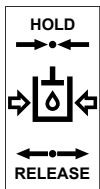
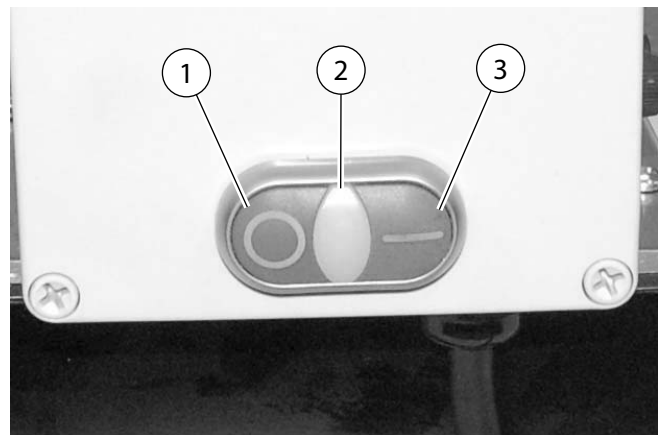

Figure 15. Release Position

11. See Figure 16. Press the STOP (red) switch to remove power from the pendant.



Item	Description
1	Stop (Red)
2	Lamp (White)
3	Start (Green)

Figure 16. Power Switch

OPERATING INSTRUCTIONS

1. See Figure 17. Open the filler cap two full turns to vent the reservoir.



Figure 17. Filler Cap

2. See Figure 18. Place the system pressure manual release valve in the hold (lever towards the motor) position.

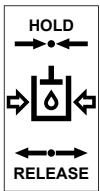

3. Make the necessary hydraulic system connections.

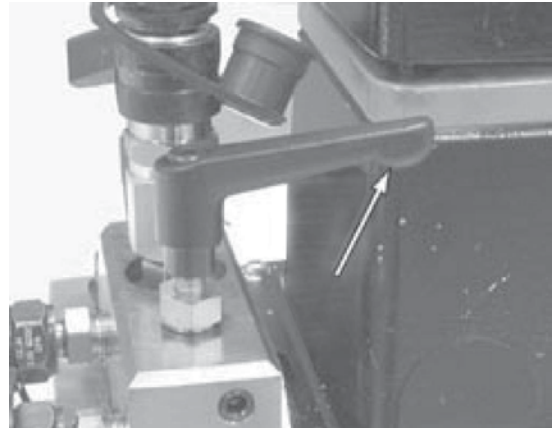

Figure 18. Hold Position

4. See Figure 19. Connect the power cord to an appropriate power source.

⚠ WARNING: To help prevent personal injury, check the voltage rating on the motor nameplate to be sure the outlet has the appropriate voltage.



Figure 19. Connected to Power Source

Operating Instructions Continued

5. Refer to Figure 20. Press the START (green) switch. Lamp (white) will illuminate and power is supplied to the pendant.

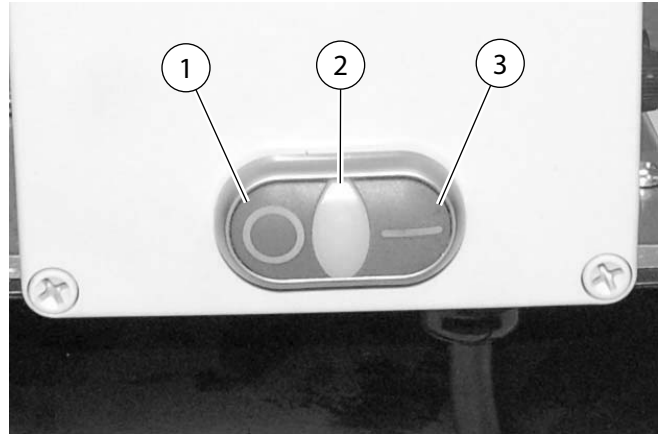

Item	Description
1	Stop (Red)
2	Lamp (White)
3	Start (Green)

Figure 20. Power Switch

- 6. See Figure 21. Using the pendant, press the POWER rocker switch to ON.
- 7. See Figure 22. Press and hold the PUMP RUN switch. The pendant will start and run the pump motor as long as the pump run switch is pressed. Switch will automatically return to OFF position when released and pump motor will turn off. Pressure will hold until the system pressure manual release lever is moved to the release (handle away from the motor) position).



Figure 21. Power ON

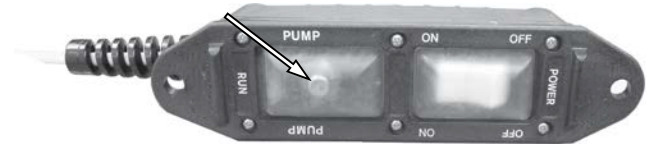

Figure 22. Pump RUN

8. See Figure 23. To release the pressure, rotate the system pressure manual release valve to the release (lever away from the motor) position.

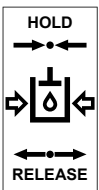
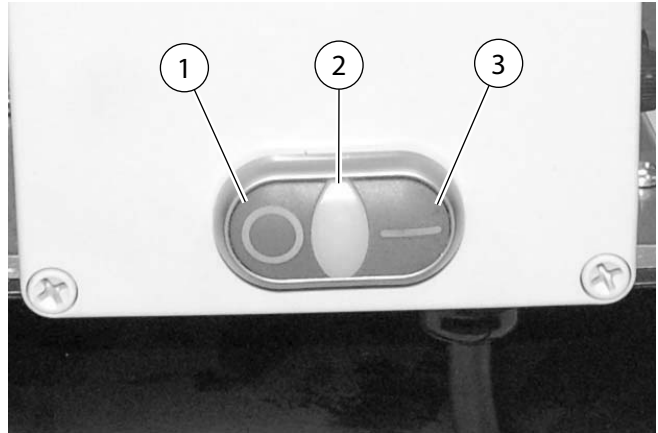

Figure 23. Release Position

Operating Instructions Continued

9. See Figure 24. Press the STOP (red) switch to remove power from the pendant.



Item	Description
1	Stop (Red)
2	Lamp (White)
3	Start (Green)

Figure 24. Power Switch

Adjusting The Pressure Regulating Valve

Note: For easy adjustment of the pressure regulating valve, always adjust the pressure by increasing to the desired pressure setting.

1. See Figure 25. Turn the pressure regulating knob a few turns in the counterclockwise direction. This decreases the pressure.

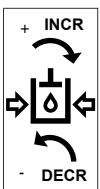
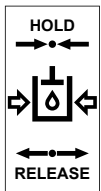

Figure 25. Pressure Regulating Valve

Operating Instructions Continued

- See Figure 26. Place the system pressure manual release valve in the hold (lever towards the motor) position.



- Verify the pump is completely connected.

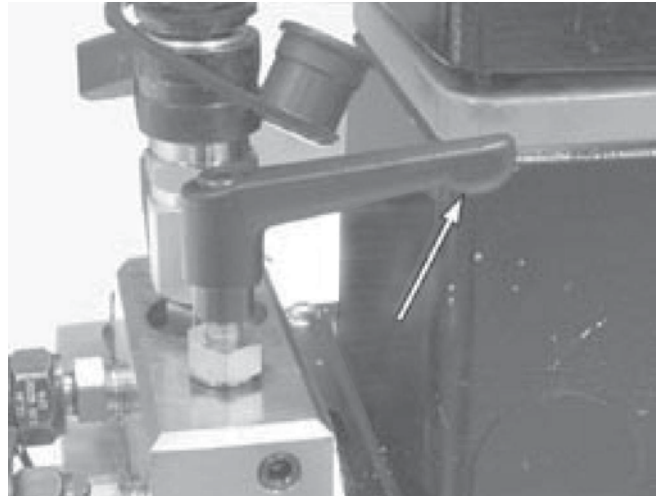
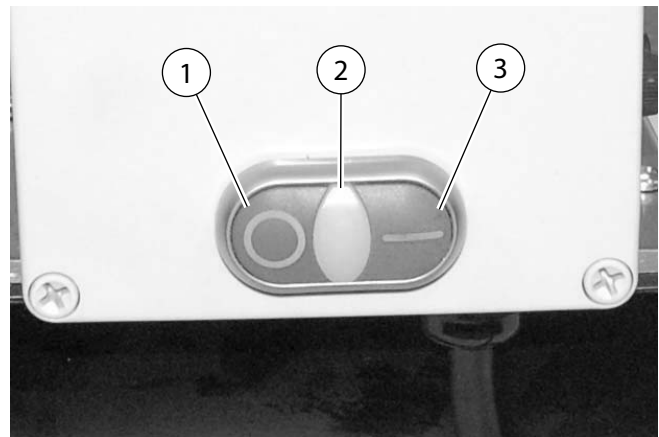

Figure 26. Hold Position

- See Figure 27. Press the START (green) switch. Lamp (white) will illuminate and power is supplied to the pendant.



Item	Description
1	Stop (Red)
2	Lamp (White)
3	Start (Green)

Figure 27. Power Switch

- See Figure 28. Using the pendant, press the POWER switch to ON.
- See Figure 29. Press and hold the PUMP RUN switch.



Figure 28. Power ON



Figure 29. Pump RUN

Operating Instructions Continued

7. See Figure 30. Slowly turn the adjusting knob in a clockwise direction until the desired pressure is reached.

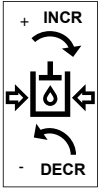

Note: The pressure range is from 0–1500 bar (0–21,750 psi).

8. Cycle the system several times to verify the pressure is set correctly.

NOTE: Pressure is retained until it is released with system pressure manual release lever.

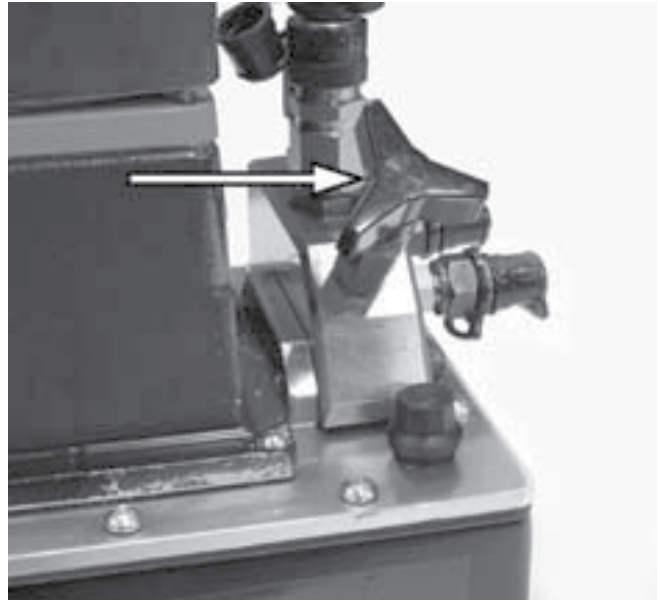

Figure 30. Pressure Regulating Valve

PERFORMANCE SPECIFICATIONS

The information in the following charts can be used as a basis to determine if the system is performing as expected during operation.

Pump	RPM	Amp Draw at 1500 bar (21,750 psi) (115V)	Amp Draw at 1500 bar (21,750 psi) (230V)	dB_A at Idle and 1500 bar (21,750 psi)	Air Supply Req'd bar (psi)
PE8 Series	14,000	11	5.5	82-86	N/A

Table 3. Drive Unit Requirements

Pump	Max. Pressure Output bar (psi)	Fluid Delivery* (cu. in./min. @)					
		0 bar (0 psi)	17.2 bar (250 psi)	50 bar (700 psi)	70 bar (1,000 psi)	345 bar (5,000 psi)	1500 bar (21,750 psi)
PE8 Series	1500 bar (21,750 psi)	-	168	15-13	15-13	13-11	8-6

* Typical delivery. Actual flow varies with field conditions.

Table 4. Fluid Pressure Chart

GENERAL MAINTENANCE

⚠ WARNING



- **Disconnect the unit from the power supply before performing maintenance or repair procedures.**
- **Repairs and maintenance are to be performed in a dust-free area by a qualified technician.**

System Evaluation

The components of your hydraulic system—tools, cylinders, pumps, hoses, and couplings—all must be:

- Rated for the same maximum operating pressure.
- Correctly connected.
- Compatible with the hydraulic fluid used.

A system that does not meet these requirements can fail, possibly resulting in serious injury. If you are in doubt about the components of your hydraulic system, contact ydraulic Technologies Technical Support.

Inspection

Keep a dated and signed inspection record of the equipment. Before each use, the operator or other designated personnel should visually inspect for the following conditions:

- Cracked or damaged cylinder or tool.
- Excessive wear, bending, damage, or insufficient thread engagement.
- Leaking hydraulic fluid.
- Scored or damaged piston rod.
- Incorrectly functioning or damaged heads and caps.
- Loose bolts or cap screws.
- Damaged or incorrectly assembled accessory equipment.
- Modified, welded, or altered equipment.
- Bent or damaged couplers or port threads.

Periodic cleaning

⚠ WARNING : **Contamination of the hydraulic fluid could cause the valve to malfunction. Loss of the load/function or personal injury could result.**

Establish a routine to keep the hydraulic system as free from debris as possible.

- Seal unused couplers with dust covers.
- Keep hose connections free of debris. Equipment attached to a cylinder must be kept clean.
- Keep the breather-hole in the filler cap clean and unobstructed.
- Use only Power Team hydraulic fluid or equivalent. Replace hydraulic fluid as recommended, or sooner if the fluid becomes contaminated. Never exceed 300 hours of use between fluid changes.

Hydraulic Fluid Level

1. Check the fluid level in the reservoir after each 10 hours of use. The fluid level should be 2.6 cm (1 in.) from the top of the fill hole when all cylinders are retracted.
2. Drain, flush, and refill the reservoir with an approved Power Team hydraulic fluid or equivalent after every 300 hours of use. The frequency of fluid changes depends upon general working conditions, severity of use, the overall cleanliness and care given to the pump. Fluid should be changed more frequently when the system is not operated regularly indoors.

General Maintenance Continued

Draining And Flushing The Reservoir

1. Clean the pump exterior before the pump assembly is removed from the reservoir.
2. See Figure 31. Remove the four screws fastening the motor to the pump assembly.
3. Remove the motor assembly and position aside. Place on a clean cloth to protect the drive gears.

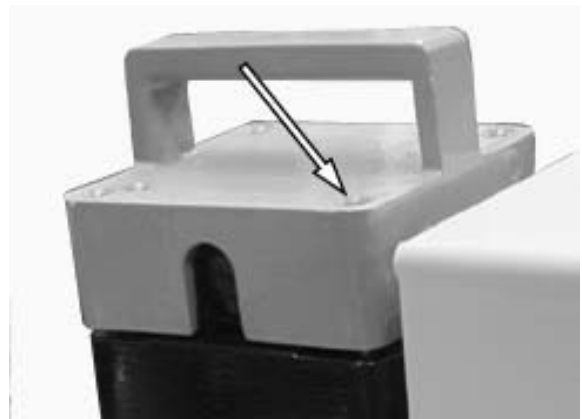

Figure 31. Motor Assembly

4. See Figure 32. Remove the 10 cover plate screws. Note the location of the hex head screws and washers. Discard the remaining screws and the copper washers.
5. Remove the pump assembly and position aside. Do not spill the fluid from the pump body.

CAUTION: Do not damage the pump filter or pressure regulating valves when lifting the pump and motor off the reservoir.



Figure 32. Cover Plate Screws

6. See Figure 33. Clean the inside of the reservoir, and fill with Power Team hydraulic fluid or equivalent. Rinse the filter screen clean.
7. Position the pump assembly and secure with two machine screws assembled on opposite corners of the housing.
8. Position the motor assembly back onto the pump assembly and install the four screws.
9. Remove the filler cap and insert a clean funnel with a filter.

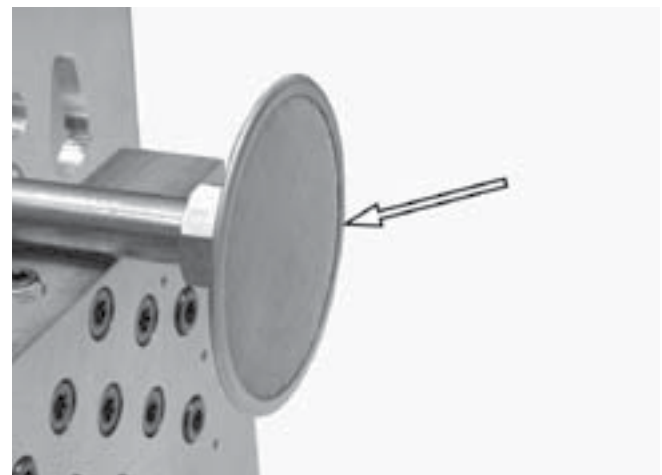
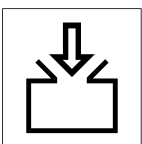

Figure 33. Filter Screen

10. Fill the reservoir with hydraulic fluid to 2.6 cm (1 in.) from the cover plate.

General Maintenance Continued

11. See Figure 34. Replace the filler cap. Verify the breather-hole is open, if applicable.
12. With the system pressure manual release valve in the release (lever away from the motor) position, run the pump for 1–2 minutes.
13. Remove the four motor assembly screws and position the motor assembly aside.

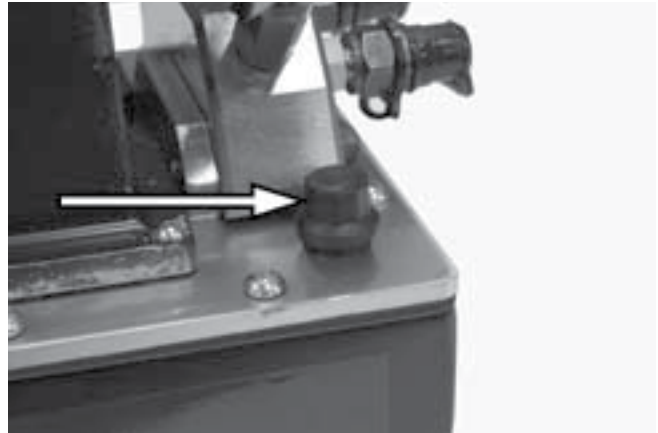
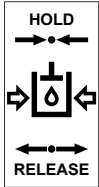

Figure 34. Filler Cap

14. Remove the two cover plate screws.
15. Remove the pump assembly and position aside.
16. Drain the fluid from the pump housing.
17. Drain and clean the inside of the reservoir.
18. Fill the reservoir. See Filling the Pump Reservoir.
19. See Figure 35. Remove the protective backing and install the new reservoir gasket with the adhesive side down.



Figure 35. Reservoir Gasket

General Maintenance Continued

20. See Figure 36. Position the pump assembly and install the new screws. Tighten screws securely and evenly to 3Nm (30 in-lbs).



Figure 36. Cover Plate Screws

21. See Figure 37. Fill the pump body with approximately 98 ml (3.3 oz) of 80W90 gear oil.



Figure 37. 80W90 Oil Level

22. See Figure 38. Clean motor gasket surfaces and install new motor gasket.
23. Position the motor assembly back onto the pump assembly.

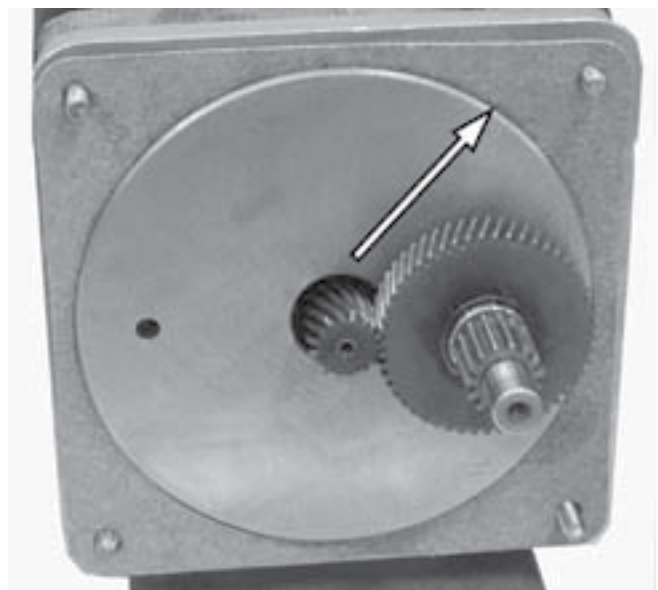

Figure 38. Motor Gasket

General Maintenance Continued

24. See Figure 39. Install the four screws and tighten 3Nm (30 in-lbs).

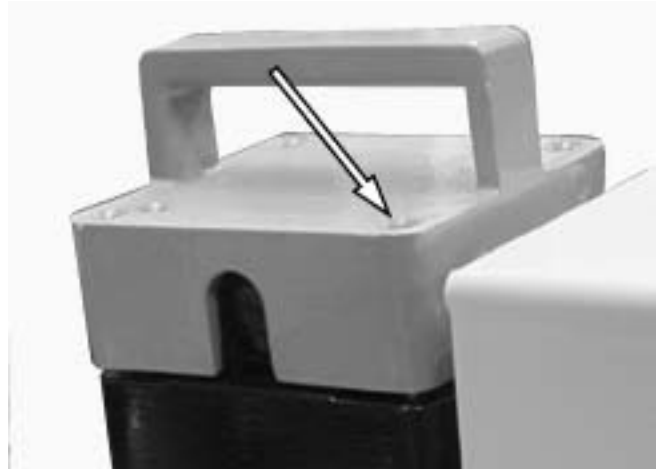

Figure 39. Motor Assembly

Adding Hydraulic Fluid To The Reservoir

1. Retract the hydraulic devices.
2. See Figure 40. Disconnect the power supply.



Figure 40. Disconnected from Power Source

3. See Figure 41. Clean the entire area around the filler plug.
4. Remove the filler cap, and install a clean funnel with a filter.

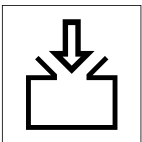

5. Use only Power Team hydraulic fluid AW 46 47 cSt @ 38°C (237 SUS @ 100°F) or equivalent. If low temperature requirements are needed, use hydraulic fluid 5.1 cSt @ 100°C (451 cSt @ -40°C). Fill to the proper level.



Figure 41. Filler Cap

General Maintenance Continued

Sound Reduction - Electrically Powered Motor

The electrically powered hydraulic pump operates in the 82-86 dBA range. If further sound reduction is desired, contact Power Team Hydraulic Technology technical support for products more suitable to your application.

Hose Connections

CAUTION : Contamination of the hydraulic fluid could cause the valve to malfunction. Loss of the load/function or personal injury could result.



IMPORTANT: Sealant tape or non-hardening sealer tape can be used to seal hydraulic connections if only one layer of tape is used. Apply tape carefully, two threads back, to prevent it from being pinched by the coupler and broken off inside the system. Loose pieces of sealant could travel through the system and obstruct the flow of fluid or cause jamming of precision-fit parts.

Storage

Store the unit in a dry, well-protected area where it will not be exposed to corrosive vapors, dust, or other harmful elements. If a unit has been stored for an extended period of time, it must be thoroughly inspected before it is used.

Checking Brushes on Electric Motors

To help prevent premature failure of the armature, check the brushes every 100 hours or 100,000 pressure cycles:

1. See Figure 42. Remove the brush holder caps and brush assemblies.



Figure 42. Brush Holder Caps

2. See Figure 43. The brush assemblies must be replaced if they are 6.35 mm (1/4") in length or less.
3. Install brush assemblies and brush holder caps.

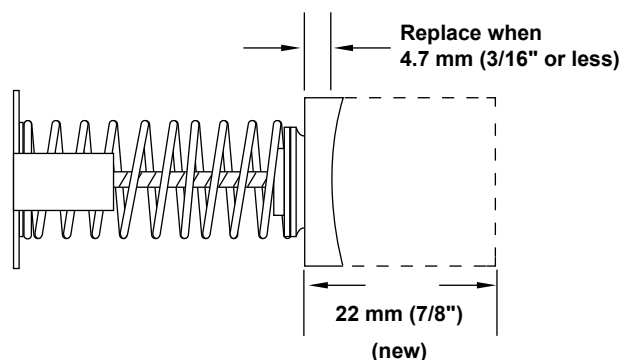

Figure 43. Brush Inspection

TROUBLESHOOTING GUIDE

⚠ WARNING



- Repair work or troubleshooting must be performed by qualified personnel who are trained and familiar with this equipment.



- Disconnect the power supply before removing the electrical cover. Electrical work should be performed by a qualified electrician.
- Check for system leaks by using a hand pump to apply pressure to the suspect area. Watch for leaking fluid and follow it back to its source. Never use your hand or other body parts to check for a possible leak.

NOTE:

- For a detailed parts list or to locate a Hydraulic Technologies facility, contact your nearest Hydraulic Technologies facility, refer to Hydraulic Technologies Facilities in this document.
- Plug the outlet ports of the pump when checking for leakage to determine if the leakage is in the pump, in the cylinder, or in the tool.

Problem	Cause	Solution
Electric motor does not run.	1. "ON" switch not depressed on control box.	1. Press "ON" switch and white lamp illuminates.
	2. Pump not turned ON.	2. Position switch to RUN position.
	3. Unit is not plugged in.	3. Plug in unit.
	4. No voltage supply.	4. Check line voltage. Check reset button on power panel.
	5. Worn brushes.	5. Replace brushes.
	6. Circuit breaker tripped because total amperage draw too high for existing circuit.	6. Use an alternate circuit or have a qualified electrician add an additional circuit.
Electric motor will not shut off.	1. Defective motor controls.	1. Disconnect unit from power supply; contact a Hydraulic Technologies facility.
Electric motor stalls, surges, overheats, or will not start under load.	1. Low voltage	1. Refer to electric motor information in Initial Setup section.
	2. Electrical cord size too small.	2. Refer to electrical cord chart in Initial Setup section.
	3. Excessive torque load on motor.	3. Contact a Hydraulic Technologies Service Center.
Electrical overload protector keeps tripping.	1. Wired incorrectly.	1. Disconnect unit from power supply; have qualified electrician review motor and circuit wiring.
	2. Excessive torque load on motor.	2. Contact a Hydraulic Technologies Service Center.
Pump delivers excess fluid pressure.	1. Faulty pressure gauge.	1. Replace gauge.
	2. Relief valve set incorrectly.	2. Contact a Hydraulic Technologies facility.

Troubleshooting Guide Continued

Problem	Cause	Solution
Pump is not delivering fluid, or delivers only enough fluid to advance connected components partially or erratically or operation to slow.	1. Fluid level too low.	1. Add fluid, refer to filling the pump reservoir in Initial Setup section.
	2. Loose-fitting coupler to component.	2. Verify quick-disconnect couplings to cylinders are completely coupled. Couplers may need to be replaced because ball check does not stay open due to wear.
	3. Air in system.	3. Refer to Initial Setup in this manual to bleed air from system.
	4. Air leak in suction line.	4. Check and tighten suction line.
	5. Debris in pump or filter plugged.	5. Clean pump filter. If problem persists, disconnect from power supply contact authorized Hydraulic Technologies facility.
	6. Fluid bypasses through the double-acting cylinder (cylinder may be in tool).	6. Remove cylinder; cap hoses. Check pump and valve for leaks.
	7. Cold fluid or fluid too heavy. (Hydraulic fluid is of a higher viscosity than necessary.)	7. Drain, flush, and refill reservoir using a lighter weight fluid. Refer to General Maintenance section.
	8. External relief valve or low pressure unloading valve out of adjustment.	8. Refer to Adjusting the Pressure Regulating Valve.
	9. Power unit/reservoir capacity is too small for the size of the cylinder(s) used.	9. Use smaller cylinder(s) or larger reservoir.
	10. Vacuum in reservoir.	10. Clean plugged vent in filler plug.
Pump builds pressure but cannot maintain pressure.	1. Fluid leakage.	1. Look for external leaks. If no fluid leakage is visible, the problem is internal. If using a double-acting cylinder, remove it from the system to ensure the leak is not in the cylinder. Seal leaking pipe fittings with pipe sealant.
	2. Loose fittings.	2. Tighten fittings.
	3. Internal check is leaking.	3. Contact a Hydraulic Technologies Service Center.

Troubleshooting Guide Continued

Problem	Cause	Solution
Pump does not build to full pressure.	1. Faulty pressure gauge.	1. Replace pressure gauge.
	2. Check for external leakage.	2. Seal faulty pipe fittings with pipe sealant.
	3. Check external pressure regulator. Check relief valve setting.	3. Refer to Adjusting the Pressure Regulating Valve.
	4. Look for internal leakage in double-acting cylinders.	4. Remove cylinder from pump. If pump builds full pressure, cylinder is defective.
	5. Inadequate air pressure (air motor only).	5. Refer to Initial Setup section.
Erratic action	1. Air in system.	1. Check for leaks. Refer to bleeding procedure.
	2. Internal leakage in attached components.	2. Refer to manufacture's information for attached component.
	3. Attached component sticking or binding.	3. Refer to manufacture's information for attached component.
	4. Malfunctioning valve.	4. Verify connections. Contact authorized Hydraulic Technologies facility.

REPAIR PROCEDURES

Fuse Replacement

1. See Figure 44. Disconnect power cord from power source.



Figure 44. Disconnected from Power Source

2. See Figure 45. Remove the fuse holder cap.
3. Replace the fuse. On 115V (nominal) replace 15A time delay 250VAC 5x20mm fuse, 230V (nominal) replace 10A time delay 250VAC 5x20mm fuse.
4. To install, reverse the removal procedure.



Figure 45. External Fuse Holder Cap

BOLTING SYSTEMS FACILITIES AND CONTACT

SALES, SERVICE AND RENTAL CENTERS

USA

Houston, Texas USA
3106 Pasadena Frwy
Pasadena, TX 77503 USA
Tel: +1 713 472 2500
Fax: +1 713 472 2501

Europe

Albert Thijsstraat 12
6471 WX Eygelshoven
The Netherlands
Tel: +31 45 567 8877

China

No.
1568 Hua Shan Road
Treasury Building, 7th Floor
Shanghai 200052, China
Tel: +86 21 2208 5660/5659/5667
Fax: +86 21 2208 5682

Corpus Christi, Texas USA

318 Centaurus Street
Corpus Christi, Texas 78405 USA
Tel: +1 361 371 6516
Fax: +1 361 687 2533

India

Hydraulic Technologies (India)
Pvt. Limited
Survey N275
Odhav Ahmedabad - 382 415

Tel: +91-99099-85454
+91-97277-19950

Australia

Hydraulic Technologies
Australia Pty Ltd
Quad 2, 6 Parkview Drive
Homebush Bay NSW 2127
Tel: +61 02 9763 4900
Fax: +61 02 9763 7888

Gonzales, Louisiana USA

3141 S. Darla Avenue
Gonzales, Louisiana 70737 USA
Tel: +1 225 774 0888
Fax: +1 225 450 2211

SEA

20 Pioneer Crescent
#06-01 West Park BizCentral
Singapore 628555
Tel: +65 6265 3343
Fax: +65 6265 6646

ENGINEERING, MANUFACTURING AND SUPPORT CENTERS

Rockford, Illinois USA

5885 11th Street
Rockford, IL 61109 USA
Tel: +1 815 874 5556
Fax: +1 800 288 7031

UK

Global Technical Assistance, UK
+44 1670 850580

EC DECLARATION OF CONFORMITY

We declare under our sole responsibility that our Electric Pump Model:

*** PE8LXX3L & PE8PXX3L**

to which this declaration relates are in conformity with the following:

<u>EN, EN-ISO, ISO standards</u>	<u>Title</u>
Per the provisions of the Machinery Safety Directive	
	2006/42 EC
EN_ISO 12100	Safety of machinery, basic concepts, general principles for design, risk assessment & risk reduction
EN 4413	Hydraulic Fluid Power – general rules and safety requirements for systems & their components

Per the provisions of the EMC Directive	
	2014/30 EU
EN_61000-4-2	Electromagnetic Discharge Immunity test
EN_61000-4-3	Radiated, Radio Frequency, Electromagnetic Field Immunity test
EN_61000-4-4	Electrical Fast Transient / Burst Immunity test
EN_61000-4-5	Surge immunity test
EN_61000-4-6	Immunity to Conducted Disturbances, Induced by Radio-Frequency Fields
EN_61000-4-11	Voltage Dip and Interrupt test
EN 55011	Industrial, Scientific and Medical (ISM) Radio Frequency Equipment-Electromagnetic Disturbance Characteristics-Limits and Methods of Measurement

Per the provisions of the Low Voltage Directive	
	2014/35 EU
EN_60204-1	Safety of Machinery –Electrical equipment of machines – Part 1 General requirements

Per the provisions of the Noise Emission in the Environment by Equipment for Use Outdoors Directive	
	2000/14 EC
EN_3200L0014	Noise emission in the environment for use outdoors
ISO 3744	Sound Power Level Measurements

measured sound power level on an equipment representative for this type :	82 dB(A)
guaranteed sound power level for this equipment :	86 dB(A) or less

Per the provisions of the RoHS Directive	
	2015/863 EU
Restriction of the use of certain hazardous substances in electrical and electronic equipment	

We hereby declare that the equipment specified under * conforms to the above quoted European Community Directive(s) and Standard(s) as per the currently valid revision. Hydraulic Technologies is certified and registered to ISO 9001: 2015.

The Netherlands September 1st, 2020



Andreas J. Klemm, PhD

Hydraulic Technologies
5885 11th Street
Rockford, IL 61109-3699
United States of America

Hydraulic Technologies
Andreas J. Klemm
Hydraulic Technologies
Albert Thijsstraat 12
NL-6471 WX Eygelshoven
The Netherlands

UKCA DECLARATION OF CONFORMITY

We declare under our sole responsibility that our Electric Pump Model:

*** PE8LXX3L & PE8PXX3L**

to which this declaration relates are in conformity with the following:

Legislation & standards

Title

The Supply of Machinery (Safety) Regulations 2008 No. 1597 and amendments

EN_ISO 12100	Safety of machinery, basic concepts, general principles for design, risk assessment & risk reduction
EN 4413	Hydraulic Fluid Power – general rules and safety requirements for systems & their components

The Electromagnetic Compatibility Regulations 2016 No. 1091

EN_61000-4-2	Electromagnetic Discharge Immunity test
EN_61000-4-3	Radiated, Radio Frequency, Electromagnetic Field Immunity test
EN_61000-4-4	Electrical Fast Transient / Burst Immunity test
EN_61000-4-5	Surge immunity test
EN_61000-4-6	Immunity to Conducted Disturbances, Induced by Radio-Frequency Fields
EN_61000-4-11	Voltage Dip and Interrupt test
EN 55011	Industrial, Scientific and Medical (ISM) Radio Frequency Equipment-Electromagnetic Disturbance Characteristics-Limits and Methods of Measurement

The Electrical Equipment (Safety) Regulations 2016 No. 1101

EN_60204-1	Safety of Machinery –Electrical equipment of machines – Part 1 General requirements
------------	---

The Noise Emissions in the Environment by Equipment for use Outdoors Regulation 2001 No. 1701

EN_3200L0014	Noise emission in the environment for use outdoors
ISO 3744	Sound Power Level Measurements

measured sound power level on an equipment representative for this type :	82 dB(A)
guaranteed sound power level for this equipment :	86 dB(A) or less

The Restriction of the Use of Certain Hazardous Substances in Electrical and Electronic Equipment Regulations 2012 No. 3032

Restriction of the use of certain hazardous substances in electrical and electronic equipment

Hydraulic Technologies

5885 11th Street
Rockford, IL 61109-3699
United States of America

Hydraulic Technologies

Ocean House, Wilmslow Road
Manchester, M20 2LY, UK
Andreas J. Klemm
Hydraulic Technologies Europe
Ltd. – Netherl.
Albert Thijsstraat 12
NL-6471 WX Eygelshoven

We hereby declare that the equipment specified under * conforms to the above quoted UK Legislation and international Standard(s) as per the currently valid revision. Hydraulic Technologies Europe Ltd. - Netherlands is certified and registered to ISO 9001: 2015.

The Netherlands February 14th, 2022



Andreas J. Klemm, PhD