

ELECTRIC HYDRAULIC PUMP

10,000 PSI

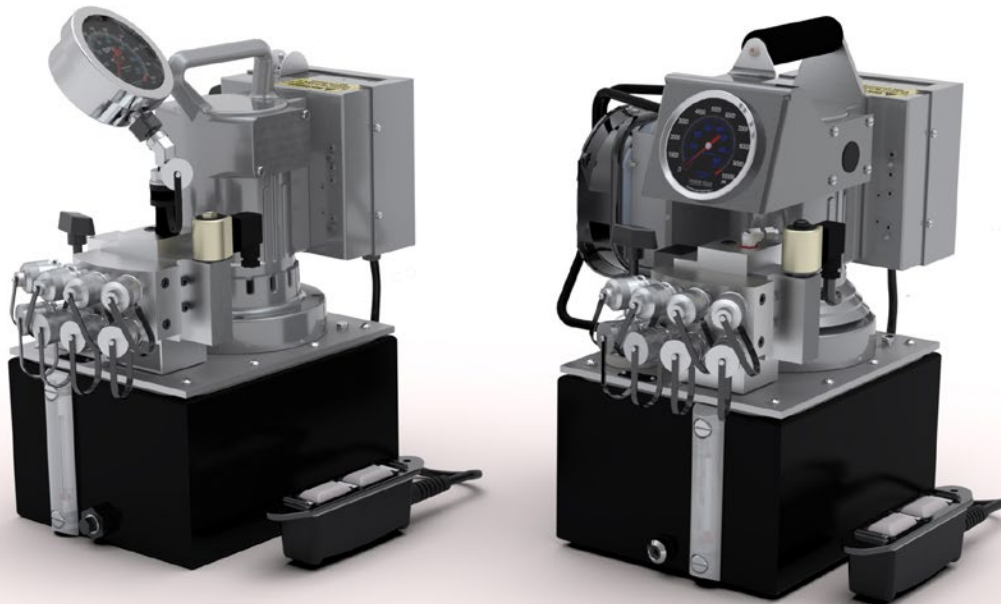

TABLE OF CONTENTS

DESCRIPTION	2
SAFETY SYMBOLS AND DEFINITIONS	3
SAFETY PRECAUTIONS	3
SET-UP INSTRUCTIONS	7
1. Filling the Reservoir	7
2. Hydraulic Connections	7
3. Electric Motor Operation	8
4. Adjusting the Hydraulic Gauge	9
5. Bleeding Air from the System	9
CONTROL VALVES	10
OPERATION	11
1. Priming the Pump	11
2. Motor Control Operation	11
3. Pressure Regulating Controls	13
PREVENTIVE MAINTENANCE	14
1. System Evaluation	14
2. Inspection	14
3. Periodic cleaning.....	14
4. Hydraulic Fluid Level	14
5. Draining and Flushing the Reservoir.....	15
6. Adding Hydraulic Fluid to the Reservoir	15
7. Sound Reduction - Electrically Powered Motor	15
8. Hose Connections.....	16
9. Storage	16
10. Checking Brushes on Universal Motors	16
TROUBLESHOOTING GUIDE	18
HYDRAULIC SCHEMATIC	22
BOLTING SYSTEMS FACILITIES AND CONTACT	23

DESCRIPTION

The 55 series hydraulic pumps are designed to have a maximum of 690 bar (10,000 psi) at a flow rate of 902 cc/min. (55 cu. in./min.). With the four-tool manifold the pump can control up to four tools at the same time. All pumps come fully assembled, less fluid, and ready for work.

Universal Motor

The universal motor offers a lightweight and portable hydraulic pump option. It is possible to start the motor under full load and, with the valve options available. The motor is a 0.8 kW (1-1/8 HP), 115 / 230 nominal VAC, 50/60 cycle single-phase. Current draw can be up to 25 amps at 115V and 13 amps at 230V. Sound level is rated at 87-92 dBA (max).

Reservoir

9.5L (2.5 Gal) or 38L (10 Gal) capacity hydraulic reservoir.

Operating Temperature

Recommended operating temperature range is -25°C to +50°C (-13°F to 122°F). If temperatures are at extremes of the operating range, it is recommended to use hydraulic fluids that are rated for those temperatures. It is recommended that you use the cooling fan option for elevated ambient temperature or continuous duty.

NOTE:

- **Carefully inspect the pump upon arrival. The carrier, not the manufacturer, is responsible for any damage resulting from shipment.**
- **Read and carefully follow these instructions. Most problems with new equipment are caused by improper operation or installation.**
- **The hydraulic power unit can be ordered with “building block” flexibility. The customer can choose from a variety of motors, controls, reservoirs, and other options. Because of the many options available, these instructions will include directions for options that your particular pump may not have.**
- **Do not change motors without consulting the pump manufacturer’s Technical Services Department.**

SAFETY SYMBOLS AND DEFINITIONS

Safety symbols are used to identify any action or lack of action that can cause personal injury. Your reading and understanding of these safety symbols is very important.

⚠ DANGER : Indicates an imminently hazardous situation which, if not avoided, will result in death or serious injury.

⚠ WARNING : Indicates a potentially hazardous situation which, if not avoided, could result in death or serious injury.

⚠ CAUTION : Indicates a potentially hazardous situation which, if not avoided, may result in minor or moderate injury.

CAUTION: Used without the safety alert symbol indicates a potentially hazardous situation which, if not avoided, may result in property damage.

IMPORTANT: Important is used when action or lack of action can cause equipment failure, either immediate or over a long period of time.

SAFETY PRECAUTIONS

These instructions are intended for end-user application needs. For a detailed parts list or to locate a Power Team Authorized Hydraulic Service Center contact your nearest Power Team facility. A list of all Power Team facilities is located at the end of this document.

⚠ WARNING : To help prevent personal injury,



- The following procedures must be performed by qualified, trained personnel who are familiar with this equipment. Operators must read and understand all safety precautions and operating instructions included with the device. If the operator cannot read these instructions, operating instructions and safety precautions must be read and discussed in the operator's native language.
- These components are designed for general use in normal environments. These components are not specifically designed for lifting and moving people, agri-food machinery, certain types of mobile machinery or special work environments such as: explosive, flammable, or corrosive. Only the user can decide the suitability of this machinery in these conditions or extreme environments. Power Team will supply information necessary to help make these decisions. Consult your nearest Power Team facility.

General



- Safety glasses must be worn at all times by the operator and anyone within sight of the unit. Additional personal protection equipment may include: face shield, goggles, gloves, apron, hard hat, safety shoes, and hearing protection.



- Operation, repair, or maintenance of hydraulic equipment should be performed by a qualified person who understands the proper function of hydraulic equipment per local directives and standards.
- Hydraulic equipment must be assembled correctly and then checked for proper function before use. Use hydraulic components of the same hydraulic pressure ratings. An appropriate hydraulic pressure gauge is recommended to monitor pressure.
- Never place your hands or other body parts near a hydraulic fluid leak. Never use your hands or other body parts to check for a possible leak. High pressure fluid can be injected under your skin causing serious injury and/or infection.

Safety Precautions Continued



- High pressure fluid is present throughout a hydraulic system. Always use caution when operating, repairing, or maintaining this equipment. Before beginning any work on any hydraulic system component, stop the equipment, disconnect from its power source, and relieve all pressure in all parts of the system. Do not tamper with the internal hydraulic relief valve settings.
- Avoid exposing hydraulic equipment (especially hoses) to extreme high or low temperatures. Damage to equipment or failure may result and cause loss of control or injury to the operator.
- Exercise caution to avoid the risk of fire.



- Do not drop any hydraulic system components. Damage to the equipment and/or injury may result.
- Avoid slipping or falling by cleaning up any oil spills.
- Avoid back injury by always lifting equipment carefully.
- It is strongly recommended to view the Power Team Hydraulic Safety video tape before using hydraulic equipment.

Hydraulic Hose

- Before operating the pump, all hose connections must be tightened with the proper tools. Do not overtighten. Connections should only be tightened securely and leak-free. Overtightening can cause premature thread failure or high pressure fittings to split at pressures lower than their rated capacities.



- Always shut off the electric motor before breaking any connections in the system.
- Should a hydraulic hose ever rupture, burst, or need to be disconnected, immediately shut off the pump. Never attempt to grasp a leaking pressurized hose with your hands. The force of escaping hydraulic fluid could cause serious injury.



- Do not subject the hose to potential hazard such as fire, sharp surfaces, extreme heat or cold, or heavy impact. Do not let the hose kink, twist, curl or bend so tightly that oil flow within the hose is blocked or reduced. Periodically inspect the hose for wear, because any of these conditions can damage the hose.
- Do not use the hose to move attached equipment. Stress can damage the hose, causing personal injury.
- Hose material and coupler seals must be compatible with the hydraulic fluid used. Hoses also must not come in contact with corrosive materials such as creosote-impregnated objects and some paints. Consult the manufacturer before painting a hose. Never paint the couplers. Hose deterioration due to corrosive materials can result in personal injury.
- Avoid straight line tubing connections in short runs (See Figure 1). Straight line runs do not provide for expansion and contraction due to pressure and/or temperature changes.
- Eliminate stress in the tube lines. Long tubing runs should be supported by brackets or clips. Tubes through bulkheads must have bulkhead fittings. This makes easy removal possible and helps support the tubing.
- Carefully inspect all hoses and fittings prior to use. Before each use, check entire hose for cuts, leaks, abrasion or bulging of cover, or damage or movement of couplings. If any of these conditions exist, replace the hose immediately. NEVER attempt to repair the hose.

Safety Precautions Continued

Pump

- Do not exceed the hydraulic pressure rating noted on the pump nameplate or tamper with the internal high pressure relief valve. Creating pressure beyond rated capacities can result in personal injury.
- Before replenishing the oil level, retract the system to prevent overfilling the pump reservoir. An overfill can cause personal injury due to excess reservoir pressure created when the wrenches are retracted.
- The load must be under operator control at all times.
- Do not connect pump to hydraulic system powered by another pump.

Power Supply



- Electrical work must be performed and tested by a qualified electrician per local directives and standards.
- Never use an ungrounded power supply with this unit.
- The pump must be compatible with existing line voltage.
- Disconnect the pump from the power supply when performing maintenance or repair on the unit.
- If the unit's power supply is damaged or the inner wiring is exposed in any way, replace immediately.
- If the power cord is damaged or wiring is exposed, replace or repair immediately.
- Changing the voltage on the jet motor (single, or three phase) is a complicated and, if not done correctly, dangerous procedure. Consult the pump manufacturer's Technical Services Department for specific information before attempting any rewiring. Rewiring voids CSA approval.
- All voltages must be wired for CW rotation when viewed from the lead end (top) of the motor.
- Check the total amperage draw for the electrical circuit you will be using. (For example: Do not plug a motor or motors that may draw 25 amps into a 20 amp fused electrical circuit.)
- Do not attempt to increase the powerline capacity by replacing a fuse with another fuse of higher value. Overheating of the powerline and the possibility of a fire will result.
- To rewire a motor from one voltage to another or when a flow control valve is changed between manual and solenoid, consult the electrical schematic in the pump's parts list.

Circuit Breakers

⚠ WARNING : If motor stops due to an overload or power outage:

- **Universal Motor:** Move motor switch to OFF and control valve to neutral. Let motor cool or wait until power is restored. Reset circuit breaker switch in power panel. (The pump motor doesn't have a circuit breaker.)
- **Single-phase Motor:** Thermal overload switch will break circuit to the motor. Move motor switch to OFF and control valve to neutral. Allow motor to cool before switching on again, or wait until power is restored.
- **Three-phase Motor:** A magnetic starter switch breaks circuit to the motor. Move the motor switch to OFF and control valve to neutral. Remove the cover on motor control box. Let the motor cool or wait until power is restored. One of three reset buttons must be pushed in to reset motor. Replace cover.

Safety Precautions Continued

Tools

DANGER

- Do not exceed rated capacities of the tools. Excess pressure may result in personal injury.
- Read and understand all safety and warning decals and instructions for devices attached.
- Inspect each tool and coupler before each shift or usage to prevent unsafe conditions from developing.
- Do not use tools if they are damaged, altered or in poor condition.
- Do not use tools with bent or damaged couplers or damaged port threads.
- Avoid pinch points or crush points that can be created by the tool.
- Never use extreme heat to disassemble hydraulic tools. Metal fatigue and/or seal damage will result and can lead to unsafe operating conditions.



IMPORTANT:

- Keep the tool clean at all times.
- Use an approved, high-grade pipe thread sealant to seal all hydraulic connections. PTFE tape can be used if only one layer of tape is used, and it is applied carefully (two threads back) to prevent the tape from being pinched by the coupler and broken off inside the pipe end. Any loose pieces of tape could travel through the system and obstruct the flow of fluid or cause jamming of precision-fit parts.
- Always use protective covers on disconnected quick couplers.

Hydraulic Fluids

- Properly dispose of all fluids, components and assemblies at the end of their useful life according to the applicable local waste-treatment and environmental regulations.
- Hydraulic fluid should be compatible with all hydraulic components.

Transport



- Do not lift hydraulic pump by any electrical cord, hose or coupler. To safely transport, always use the carrying handle, roll cage or suitable lifting aid, along with assistance and proper lifting techniques.

Note: The guide cannot cover every hazard or situation so always do the job with **SAFETY FIRST**.

SET-UP INSTRUCTIONS

1. Filling the Reservoir

NOTE: Most pumps are shipped without hydraulic fluid in the reservoir. Hydraulic fluid may have been shipped in a separate container, but if hydraulic fluid is needed, use only approved Power Team hydraulic fluid rated at AW 46 47 cSt @ 38°C (215 SUS @ 100°F). If low temperature requirements are needed, use hydraulic fluid 5.1 cSt @ 100°C (451 cSt @ -40°C).

- A. Clean the area around the filler cap to remove all dust and grit. Any dirt or dust in the oil can damage the polished surfaces and precision-fit components of the pump.
- B. Retract all cylinders to the return position.
- C. Remove the filler cap, and insert a clean funnel and filter. Fill with hydraulic oil to 1/2" from the top of the filler hole. Replace filler cap with the breather-hole in the filler cap open.
- D. Cycle the pump (with wrench attached) several times. Retract the wrench, and check the oil level in the pump reservoir again.

2. Hydraulic Connections

- A. Clean the areas around the fluid ports of the pump and wrench.
- B. Inspect all threads and fittings for signs of wear or damage, replace as needed.
- C. Clean all hose ends, couplers or union ends.
- D. Remove the thread protectors from the hydraulic fluid outlets. Connect the hose assembly to the hydraulic fluid outlet, and couple the hose to the tool. Although a high-grade, non-hardening thread sealant is preferred, PTFE tape may be used to seal hydraulic connections if only one layer of tape is used. Apply carefully to prevent the tape from being pinched by the coupler and broken off inside the pipe end. Any loose pieces of tape could travel through the system and obstruct the flow of oil.

CAUTION : To prevent personal injury from leaking hydraulic fluid, seal all hydraulic connections with a high-quality, non-hardening, pipe thread sealant.



IMPORTANT: Sealant tape or non-hardening sealer tape can be used to seal hydraulic connections if only one layer of tape is used. Apply tape carefully, two threads back, to prevent it from being pinched by the coupler and broken off inside the system. Loose pieces of sealant could travel through the system and obstruct the flow of fluid or cause jamming of precision-fit parts.

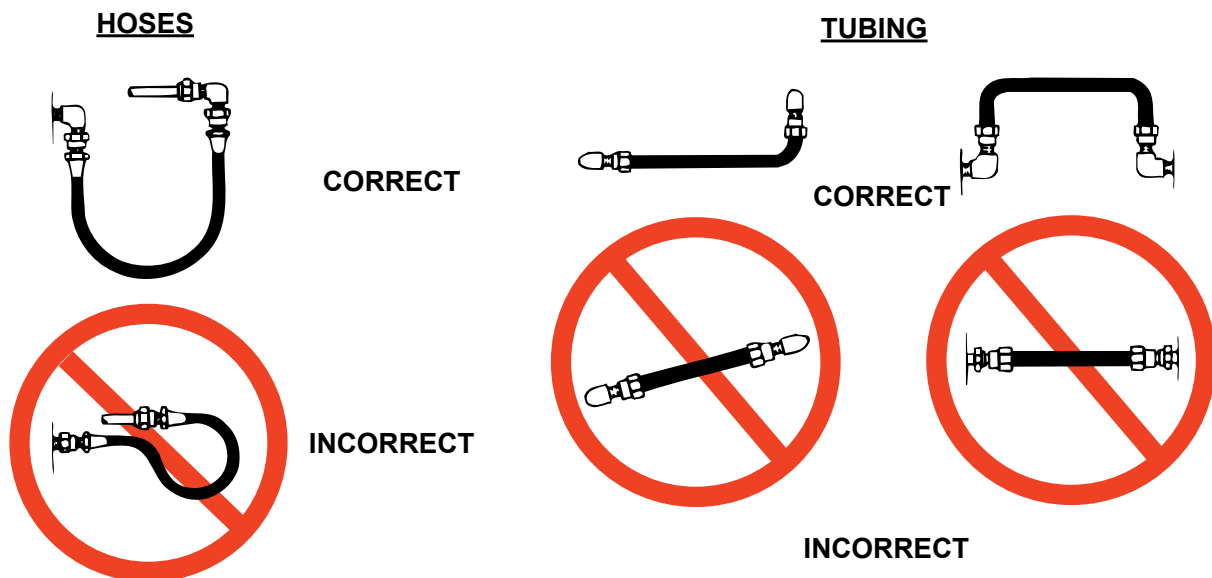

Fig. 1. Hoses and Tubing Connections

Set-Up Instructions Continued

3. Electric Motor Operation

⚠ WARNING : Electrical work must be performed and tested by a qualified electrician per local directives and standards.

Universal Motor: The universal motor is wired for 115 or 230 volts, 50/60 cycles according to the customer's request. **This motor cannot be rewired.**

- A. Verify the valve is in the neutral or hold position (If applicable).
- B. Connect the power cord to an appropriate power source.

⚠ CAUTION

- The correct voltage is required for the pump to operate. Verify the voltage rating on the pump motor name plate matches the outlet or power source you are using. Low voltage may cause: an overheated motor; a motor that fails to start under load; motor surging when trying to start; or a stalled motor before maximum pressure is reached.
- Check the voltage at the motor with the pump running at full pressure.
- Never run the motor on long, light gauge (small cross-section) extension cords. Refer to the minimum recommended gauge (cross-section) chart below.

AMPS at Maximum Hyd. Pressure	Electrical Cord Size AWG (mm ²) 3.2 Volt Drop			
	Length of Electrical Cord			
	0-25 ft. (0-8 m)	25-50 ft. (8-15 m)	50-100 ft. (15-30 m)	100-150 ft. (30-46 m)
6	18 (0.75)	16 (1)	14 (1.5)	12 (2.5)
10	18 (0.75)	14 (1.5)	12 (2.5)	10 (4)
14	16 (1)	12 (2.5)	10 (4)	8 (6)
18	14 (1.5)	12 (2.5)	8 (6)	8 (6)
22	14 (1.5)	10 (4)	8 (6)	6 (10)
26	12 (2.5)	10 (4)	8 (6)	6 (10)
30	12 (2.5)	10 (4)	6 (10)	4 (16)

Table 1. Minimum Recommended Gauge

- C. Start the pump and shift as required.
- D. Turn off the pump when not in use.

Set-Up Instructions Continued

4. Adjusting the Hydraulic Gauge

Locate the adjustment screw on the gauge (See Figure 2) and make adjustments as needed with a screwdriver. The adjustment screw is located on the lower right back rim of the gauge. You must reach under the portion of the shroud that the gauge is mounted in.

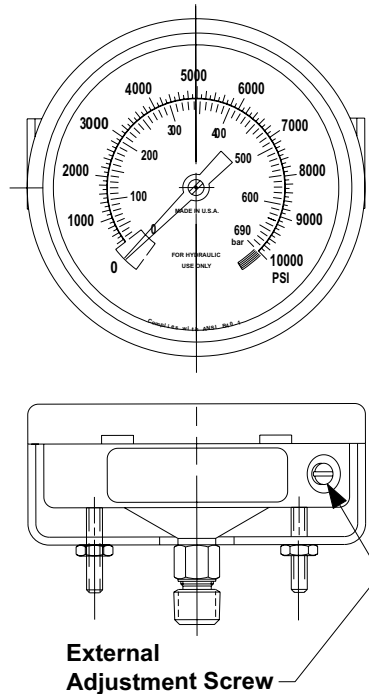

Figure 2

5. Bleeding Air from the System

After all connections are made, the hydraulic system must be bled of any trapped air. With no load on the system and the pump vented and positioned higher than the hydraulic device, cycle the system several times. Check the reservoir fluid level and fill to proper level with Power Team hydraulic fluid as necessary. If there is a problem contact the Power Team.

CONTROL VALVES

Max. Capacity: 690 bar (10,000 psi)

	Valve Function	Use with Cylinder Type	Valve No.
<p>115 115-CF 115CC-NA 230 230-CF 115CC-NA</p>	<div style="display: flex; justify-content: space-around;"> <div style="text-align: center;"> <p>SOLENOID "ON"</p> <p>Advance</p>  <p>Port "A" Port "B"</p> <p>P T</p> <p>From Pump To Tank</p> </div> <div style="text-align: center;"> <p>SOLENOID "OFF"</p> <p>Retract</p>  <p>Port "A" Port "B"</p> <p>P T</p> <p>From Pump To Tank</p> </div> </div>	<p>Torque Wrench only NOT FOR LIFTING</p>	<p>3000786 for 115, 115CC-NA, 230 and 230CC-NA)</p> <p>3000113CL for (115-CF and 230-CF)</p> <p>(4-way, 2-Position, Open Center, Solenoid/Pneumatic Controlled, Pilot Operated, 4 Tool)</p>
Diagram			
			

Table 2. Pump Configurations

OPERATION

1. Priming the Pump

When operating the pump for the first time

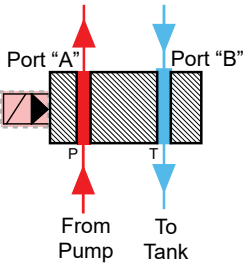
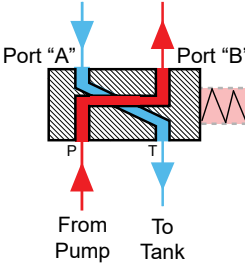
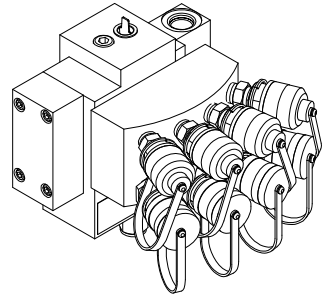
- A. Valve and hose connections must be tight, and the reservoir must be filled to the proper oil level.
- B. Jog the pump several times to build pressure. If the pump doesn't build pressure, it may not be primed. Disconnect a hose from the system and route it back to the pump reservoir. Run the pump until a steady flow of oil is observed free of suspended air bubbles. Reconnect the hose to the system.
- C. Run the tool several times to eliminate air from the system. For more complete instructions, refer to the section titled "Bleeding Air from the System."
- D. The pump is now ready to be put into regular operation.

IMPORTANT: After eliminating trapped air from system, retract the wrenches and refill the pump reservoir to 1/2" from the top of the filler hole.

2. Motor Control Operation

Depending on system requirements: Several motor control hand pendant models are listed below. Pendants are available depending on the pump configuration.

See Figure 4. Hand Pendant Controller (ADVANCE, RETRACT, OFF and SET)

- A. Connect the power cord to an appropriate power source.
- B. Place the motor control switch in the ON position or the REMOTE position, if applicable. Refer figure 3.
- C. Refer to figure 4. Press rocker switch so it is in the OFF position.
- D. While the rocker switch is in the OFF position, depress and release the SET button. This arms the system and the pump is ready to use.
- E. Depress the rocker switch to the ADVANCE position and motor will start and tool will advance. Release rocker switch to select RETRACT and tool will return to starting position. At this point the rocker can again be depressed to ADVANCE to start cycle over until fastener is tight.
- F. Depress rocker switch to OFF to stop pump.

NOTE: If pump is turned off by operator or if the built in retract timer shuts down the unit, follow C, D and E sequence above to ensure restart.

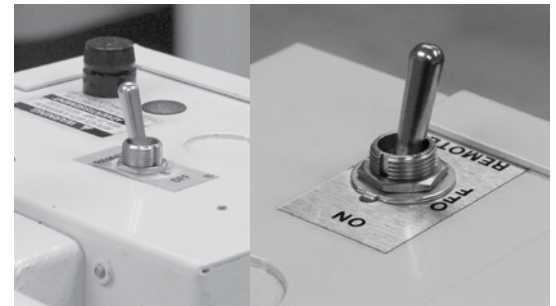

Fig. 3. Motor Control Switches

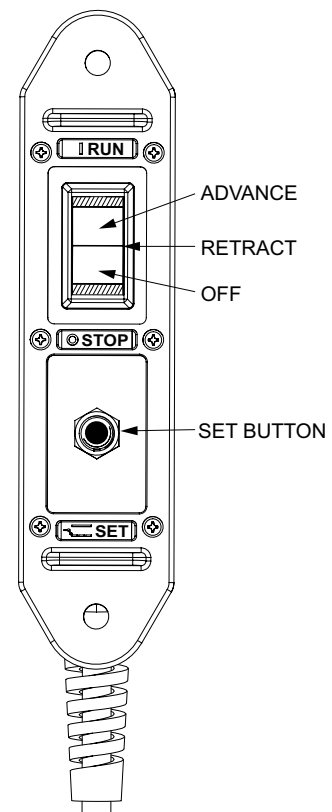

Fig. 4. Hand Pendant Controller

Operation Continued

See Figure 5. Hand Pendant Controller (ON, OFF, ADVANCE and RETRACT)

Note: Pumps with “CC” in part number, see Figure 5 and following instructions for pump operation.

- A. Make sure ON/OFF rocker switch is set to OFF before pump is connected to power supply (Failure to follow this step may cause unintended tool operation and operator injury).
- B. Depress ON/OFF rocker switch to the ON position, switch will detent to ON and motor will start with pump acting in the RETRACT condition.
- C. Depress rocker switch to ADVANCE position and tool will begin operation. Release ADVANCE rocker switch and tool will begin retracting to the start position. Once at start position, depress ADVANCE rocker again to repeat cycle until work is complete.
- D. Depress ON/OFF rocker switch to OFF position when pump is not being used.

NOTE: If pump is left running in RETRACT, after 45 seconds a timer will shut the motor off. Depressing ADVANCE rocker will restart motor and tool will begin operation.

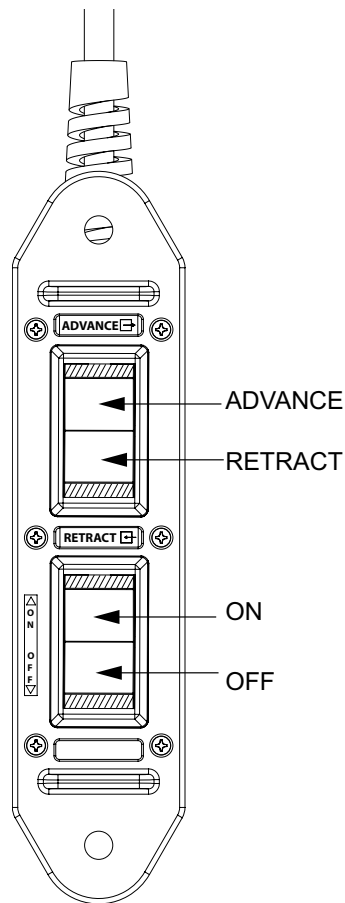

Fig. 5. Hand Pendant Controller

Operation Continued

3. Pressure Regulating Controls

User adjustable relief valve (if equipped): All others are factory preset

NOTE: For easy adjustment of the pressure regulating valve, always adjust the pressure by increasing to the desired pressure setting.

- A. Loosen the locknut on the pressure regulating valve, and back the adjusting screw or knob out a few turns by turning it in a counterclockwise (CCW) direction (See Figure 6). This will decrease the setting to a lower than desired pressure.
- B. The pump must be completely connected electrically and hydraulically. Start the pump and build pressure.
- C. Slowly turn the adjusting screw or knob in a clockwise (CW) direction. This gradually increases the pressure setting. When the desired pressure is reached, cycle the pump again to verify correct pressure setting. Once set, lock the adjusting screw in position by tightening the locknut. Shut off the pump.

IMPORTANT: The pressure range is from 1,000 to 10,000 PSI (69 to 690 BAR) depending on the pump model.

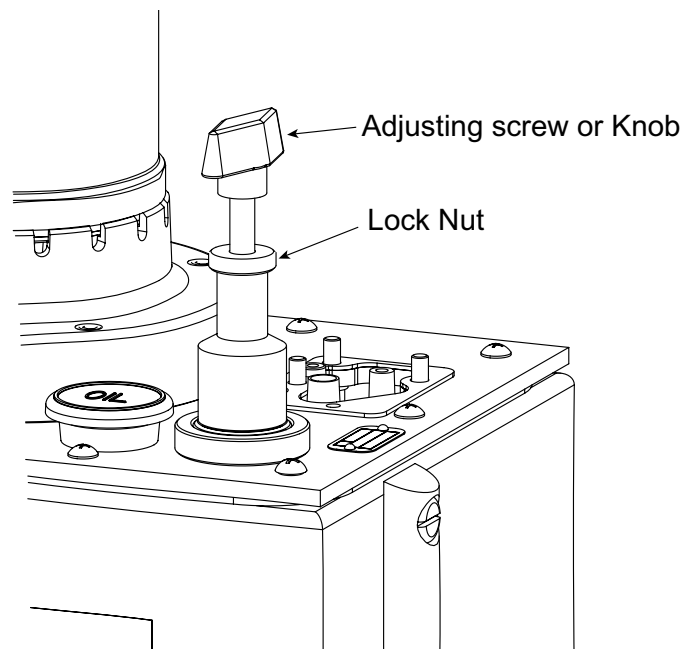

Fig. 6. Pressure Regulator Valve

PREVENTIVE MAINTENANCE

⚠ WARNING : To prevent personal injury,



- Disconnect the unit from the power supply before performing maintenance or repair procedures.
- Repairs and maintenance are to be performed in a dust-free area by a qualified technician.

1. System Evaluation

The components of your hydraulic system — tools, pumps, hoses, and couplings — all must be:

- Rated for the same maximum operating pressure.
- Correctly connected.
- Compatible with the hydraulic fluid used.

A system that does not meet these requirements can fail, possibly resulting in serious injury. If you are in doubt about the components of your hydraulic system, contact Power Team Technical Support.

2. Inspection

Keep a dated and signed inspection record of the equipment. Before each use, the operator or other designated personnel should visually inspect for the following conditions:

- Cracked or damaged tool.
- Excessive wear, bending, damage, or insufficient thread engagement.
- Leaking hydraulic fluid.
- Scored or damaged piston rod.
- Incorrectly functioning or damaged heads and caps.
- Loose bolts or cap screws.
- Damaged or incorrectly assembled accessory equipment.
- Modified, welded, or altered equipment.
- Bent or damaged couplers or port threads.

3. Periodic Cleaning

⚠ WARNING : Contamination of the hydraulic fluid could cause the valve to malfunction. Loss of the load or personal injury could result.

Establish a routine to keep the hydraulic system as free from debris as possible.

- Seal unused couplers with dust covers.
- Keep hose connections free of debris. Equipment attached to a tool must be kept clean.
- Keep the breather-hole in the filler cap clean and unobstructed.
- Use only Power Team hydraulic fluid. Replace hydraulic fluid as recommended, or sooner if the fluid becomes contaminated. Never exceed 300 hours of use between fluid changes.

4. Hydraulic Fluid Level

- A. Check the fluid level in the reservoir after each 10 hours of use. The fluid level should be 1.3 cm (0.5 in.) from the top of the fill hole when all cylinders are retracted.
- B. Drain, flush, and refill the reservoir with an approved, high-grade hydraulic oil after every 300 hours of use. The frequency of oil changes depends upon general working conditions, severity of use, the overall cleanliness and care given to the pump.

Preventive Maintenance Continued

5. Draining and Flushing the Reservoir

IMPORTANT: Clean the pump exterior before the pump interior is removed from the reservoir.

- A. Remove the ten screws fastening the motor and pump assembly to the reservoir.

IMPORTANT: Do not damage the gasket or bump the filter or pressure regulating valves when lifting the pump and motor off the reservoir. See Figure 7.

- B. Clean the inside of the reservoir, and fill with a suitable Power Team hydraulic fluid. Rinse the filter clean.
- C. Place the pump and motor assembly back onto the reservoir, and secure with two machine screws assembled on opposite corners of the cover plate.

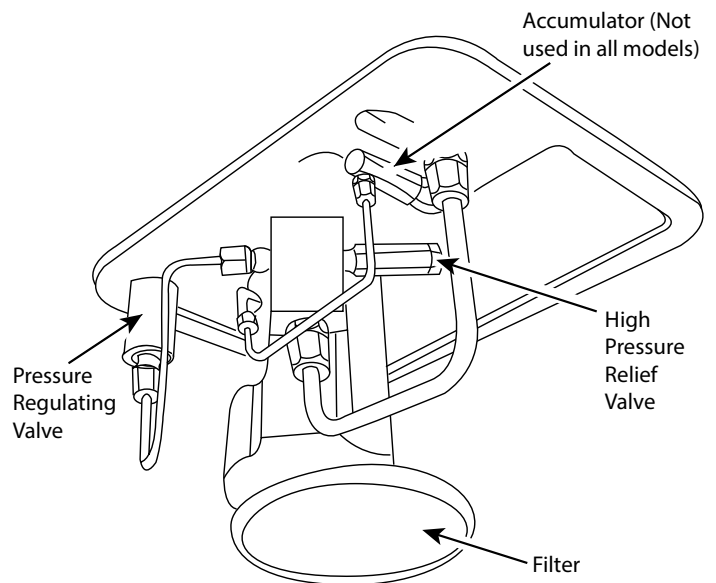

Fig. 7. Pump Assembly

IMPORTANT: The hydraulic flow control valve must be in the neutral position for the following step. If the pump is equipped with a valve that has only an advance or retract position, place the valve in the advance position, and connect a hose to the advance port on the valve. Place the other end of the hose into the oil filler plug hole.

- D. Run the pump for several minutes. Then disconnect the motor and pump assembly, and drain and clean the inside of the reservoir.
- E. Fill the reservoir with an approved, high-grade hydraulic oil. Place the pump and motor assembly (with gasket) on the reservoir, and thread the ten screws. Tighten securely and evenly.

6. Adding Hydraulic Fluid to the Reservoir

- A. Wrench must be fully retracted and the power supply disconnected when adding oil to the reservoir.
- B. Clean the entire area around the filler plug.
- C. Remove the filler plug, and install a clean funnel with a filter.
- D. Use only Power Team hydraulic fluid AW 46 47 cSt @ 38°C (215 SUS @ 100°F).
- E. If low temperature requirements are needed, use hydraulic fluid 5.1 cSt @ 100°C (451 cSt @ -40°C).

7. Sound Reduction - Electrically Powered Motor

The electrically powered hydraulic pump operates in the 90-95 dBA range. If further sound reduction is desired, any of the following options will help reduce the sound level.

- A. Use a 3450 RPM, 1-1/2 horsepower, 115 VAC, 60 Hz, 1-phase pumping unit.
- B. Use a 3450 RPM, 1-1/2 horsepower, 230 VAC, 60 Hz, 3-phase pumping unit.
- C. Install casters (two gallon reservoir only) to reduce the noise level.
- D. Contact Power Team Hydraulic Technology technical support for products more suitable to your application.

Preventive Maintenance Continued

8. Hose Connections

CAUTION :To prevent personal injury from leaking hydraulic fluid, seal all hydraulic connections with a high-quality, non-hardening, pipe thread sealant.



IMPORTANT: Sealant tape or non-hardening sealer tape can be used to seal hydraulic connections if only one layer of tape is used. Apply tape carefully, two threads back, to prevent it from being pinched by the coupler and broken off inside the system. Loose pieces of sealant could travel through the system and obstruct the flow of fluid or cause jamming of precision-fit parts.

9. Storage

Store the unit in a dry, well-protected area where it will not be exposed to corrosive vapors, dust, or other harmful elements. If a unit has been stored for an extended period of time, it must be thoroughly inspected before it is used.

10. Checking Brushes on Universal Motors

To help prevent premature failure of the armature, check the brushes periodically:

- A. Remove the metal brush cover plates.
- B. Remove the brush holder caps and brush assemblies.
- C. The brush assemblies must be replaced if they are 4.5mm (1/8") long or less. See Figure 8.
- D. Install brush assemblies, brush holder caps, and metal brush cover plates.

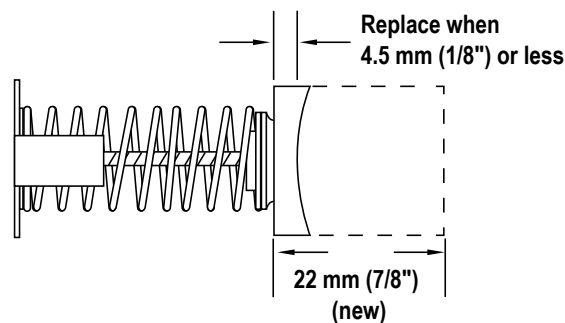
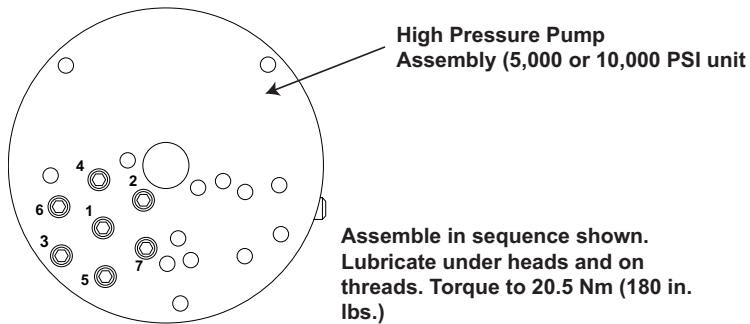

Fig. 8. Brush Inspection

REASSEMBLY SPECIFICATIONS

HIGH PRESSURE PUMP ASSEMBLY BOLT TIGHTENING SEQUENCE



BRUSH HOLDER & ARMATURE INSTALLATION SPECIFICATIONS

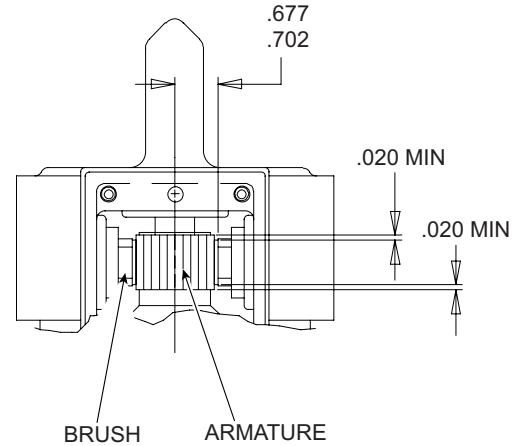

WHEN REPLACING BRUSHES OR THE ARMATURE, THE DIMENSIONS SHOWN MUST BE AS SPECIFIED

NEEDLE BEARING INSTALLATION SPECIFICATIONS

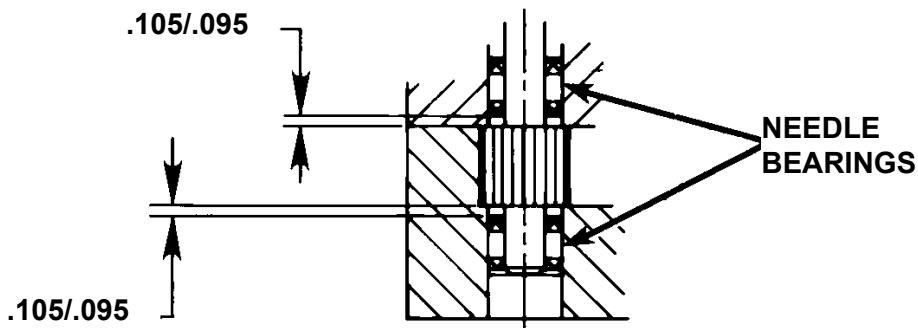

When replacing the needle bearings on the drive gear of the basic pump, the dimensions shown must be as specified

TROUBLESHOOTING GUIDE

⚠ WARNING



- Repair work or troubleshooting must be performed by qualified personnel who are familiar with this equipment.
- Disconnect the power supply before removing the electrical cover. Electrical work should be performed by a qualified electrician.



- Check for system leaks by using a hand pump to apply pressure to the suspect area. Watch for leaking fluid and follow it back to its source. Never use your hand or other body parts to check for a possible leak.

NOTES:

- For a detailed parts list or to locate a Power Team Authorized Hydraulic Service Center, contact your nearest Power Team facility.
- Plug the outlet ports of the pump when checking for leakage to determine if the leakage is in the pump or in the tool.

TROUBLE	CAUSE	SOLUTION
<p>⚠ WARNING</p> <p>To help prevent personal injury, disconnect power supply before removing cover. Any electrical work should be performed by a qualified electrician.</p>	1. Pump not turned ON.	1. Flip toggle switch to “Run” position.
	2. Unit is not plugged in.	2. Plug in unit.
	3. No voltage supply.	3. Check line voltage. Check reset button on power panel.
	4. Broken lead wire or defective power cord plug.	4. Replace defective parts.
	5. Defective switches.	5. Check switches.
	6. Defective motor.	6. Repair or replace motor.
	7. Defective starter relay.	7. Replace defective parts.
	8. Defective remote switch.	8. Repair or replace remote switch.
	9. Worn brushes.	9. Replace brushes.
	10. Circuit breaker tripped because total amperage draw too high for existing circuit.	10. Add an additional circuit or use alternate circuit.
	11. Overheated motor (single-phase motor only). Magnetic starter disengaged (three-phase motor only). Thermal protector open.	11. Wait for motor to cool before restarting. Reset thermal protector (Single-phase motor will reset automatically.)
	12. Faulty thermal protector (single phase motor). Faulty magnetic starter (three-phase motor).	12. Replace

Troubleshooting Guide Continued

TROUBLE	CAUSE	SOLUTION
Pump is not delivering oil or delivers only enough oil to advance wrench(s) partially or erratically.	1. Oil level too low.	1. Fill reservoir to 1/2" from top of filler hole with wrench retracted.
	2. Loose-fitting coupler to wrench.	2. Check quick-disconnect couplings to wrench. Inspect couplers to ensure that they are completely coupled. Occasionally couplers have to be replaced because the ball check does not stay open due to wear
	3. Air in system.	3. Bleed the system.
	4. Air leak in suction line.	4. Check and tighten suction line.
	5. Dirt in pump or filter plugged.	5. Pump filter should be cleaned and, if necessary, pump should be dismantled and all parts inspected and cleaned.
	6. Oil is bypassing through the double-acting wrench.	6. By removing the wrench and capping the hoses, the pump and valve can be checked. Observe if pump holds pressure.
	7. Cold oil or oil too heavy (Hydraulic oil is of a higher viscosity than necessary)	7. Change to a lighter oil.
	8. Relief valve or low pressure unloading valve out of adjustment.	8. Adjust as needed.
	9. Reservoir capacity is too small for the size of the wrench(s) used.	9. Use smaller wrench(s) or larger reservoir.
	10. Defective directional valve.	10. Inspect all parts carefully and replace if necessary.
	11. Sheared drive shaft key(s).	11. Replace
	12. Motor rotating in wrong direction.	12. 12,000 RPM motor: Reverse lead wires to brush holders.
	13. Vacuum in reservoir.	13. Check for plugged vent in filler plug.
	14. Low pressure pump worn.	14. Remove end cap from low pressure gear pump. Clean pump, and replace worn gears, shifting spool, body or end cap.

Troubleshooting Guide Continued

TROUBLE	CAUSE	SOLUTION
Pump builds pressure but cannot maintain pressure.	1. Check to see if there are any external leaks. If no oil leakage is visible, the problem is internal. If using a double-acting wrench, remove it from the system to ensure that the leak is not in the wrench.	1. Seal leaking pipe fittings with pipe sealant.
	2. To test for a leaking control valve, lift the pump from the reservoir but keep the filter in the oil. Remove the drain line to see if the oil is leaking from the valve. If the valve is not leaking, the internal check valve could be leaking. Refer to the note concerning checking for oil leaks at the beginning of this troubleshooting Guide.	2. Clean, reseal or replace flow control valve parts. If the internal check valve(s) are leaking, the pump must be dismantled and the seat areas repaired, poppets replaced, etc.
	3. Leaking pressure switch seal.	3. Repair or replace seal
Wrench will not retract.	1. Check the system pressure; if the pressure is zero, the control valve is releasing pressure and the problem may be in the wrench, mechanical linkage connected to wrench(s), or quick-disconnect couplings.	1. Check the wrench for broken return springs, and check couplers to ensure that they are completely coupled. Occasionally couplers have to be replaced because one check does not stay open in the coupled position.
	2. Defective valve.	2. Check valve operation and inspect parts. Replace if necessary.
	3. Inadequate air pressure (air motor model only).	3. Increase air pressure.
Pump delivers excess oil pressure.	1. Faulty pressure gauge.	1. Calibrate gauge.
	2. Relief valve not properly set.	2. Adjust the relief valve.

Troubleshooting Guide Continued

TROUBLE	CAUSE	SOLUTION
Pump will not build full pressure.	1. Faulty pressure gauge.	1. Calibrate gauge.
	2. Check for external leakage.	2. Seal faulty pipe fitting with pipe sealant
	3. Check the external pressure regulator. Check the relief valve setting.	3. Lift the pump from the reservoir, but keep the filter immersed in oil. Note the pressure reading when the relief valve begins to open. If functioning normally, it should start to leak off at relief valve pressure.
	4. Look for internal leakage in double-acting wrench.	4. Remove the wrench from the pump. If the pump builds full pressure, the wrench is defective.
	5. Check for leaks in the flow control valve.	5. Clean and reseal or replace parts.
	6. Inspect the pump for internal leakage. Check high pressure pump inlet or outlet ball checks.	6. Same procedure as above, but look for leaks around the entire inner mechanism. If there are no visible leaks, the high pressure pump subassembly may be leaking. Remove all parts. Check the valve head assembly body for any damage to the seat area. Clean and reseal if necessary. Inspect for damage and replace if necessary, then reassemble.
	7. Sheared key(s)	7. Replace
	8. Inadequate air pressure (air motor only).	8. Increase air pressure.
	9. Shifting spool seat and/or shifting spool poppet (located under high pressure pump assembly) worn.	9. Clean and reseal or replace.
	10. Shifting spool o-ring (located within shifting spool bore) worn or broken.	10. With an o-ring pick, remove o-ring and backup washer through low pressure pump assembly end. Replace.

HYDRAULIC SCHEMATIC

For 115, 230 and 115CC-NA

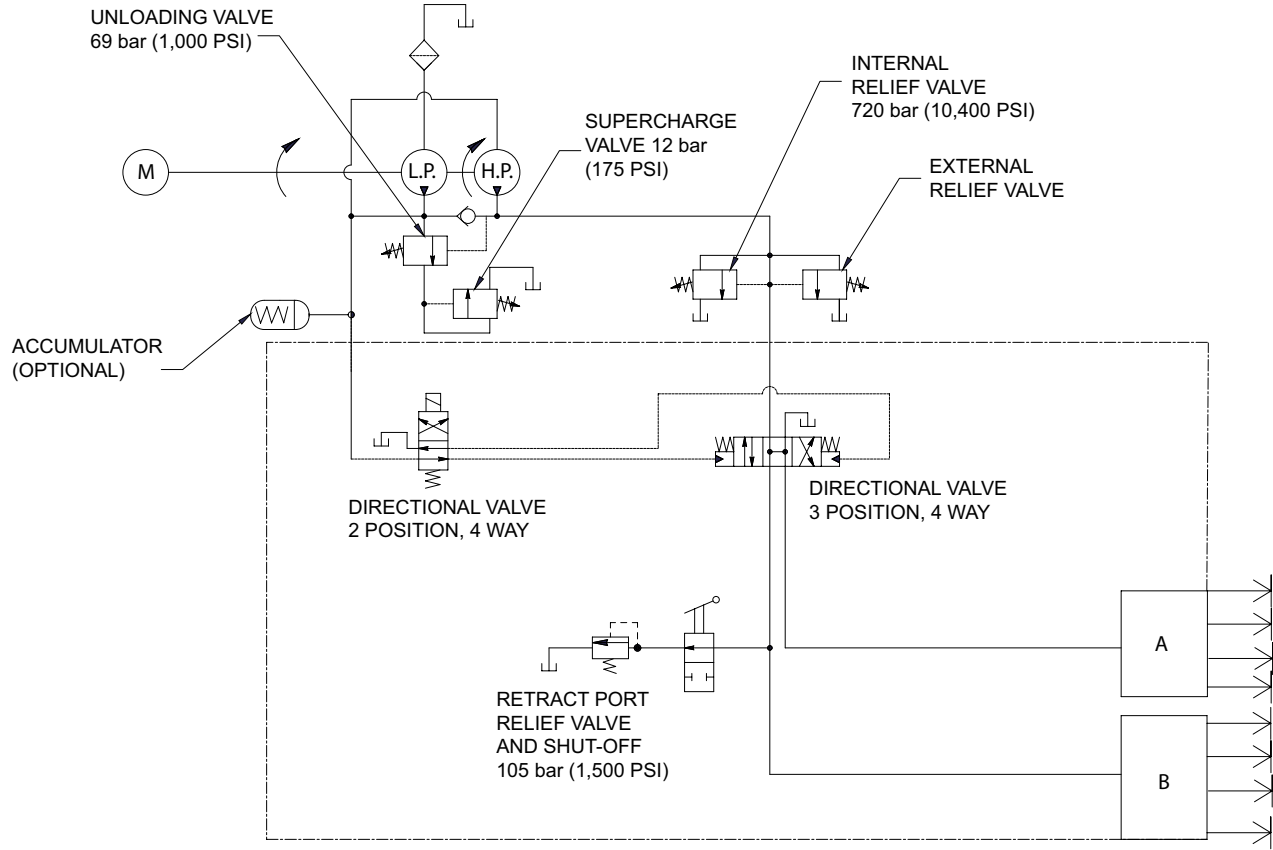

For 115-CF and 230-CF

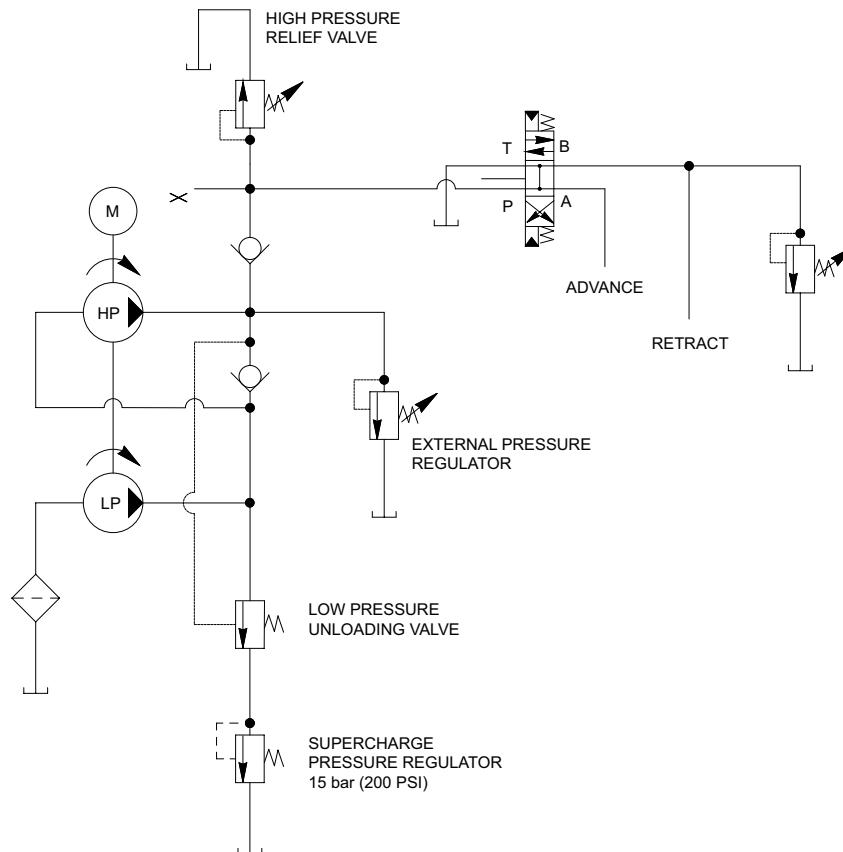

BOLTING SYSTEMS FACILITIES AND CONTACT

SALES, SERVICE AND RENTAL CENTERS

USA

Houston, Texas USA
3106 E. Pasadena Frwy
Pasadena, TX 77503 USA
Tel: +1 713 472 2500
Fax: +1 713 472 2501

Corpus Christi, Texas USA

318 Centaurus Street
Corpus Christi, Texas 78405 USA
Tel: +1 361 371 6516
Fax: +1 361 687 2533

Gonzales, Louisiana USA

3141 S. Darla Avenue
Gonzales, Louisiana 70737 USA
Tel: +1 225 774 0888
Fax: +1 225 450 2211

Europe

Albert Thijsstraat 12
6471 WX Eyselshoven
The Netherlands
Tel: +31 45 567 8877

India

Hydraulic Technologies
(India) Pvt. Limited
Survey No 275
Odhav, Ahmedabad - 382 415
Tel: +91-99099-85454
+91-97277-19950

SEA

20 Pioneer Crescent #06-01
West Park BizCentral
Singapore 628555
Tel: +65 6265 3343
Fax: +65 6265 6646

China

No 568 Hua Shan Road
Treasury Building, 7th Floor
Shanghai 200052, China
Tel: +86 21 2208 5660/5659/5667
Fax: +86 21 2208 5682

Australia

Hydraulic Technologies
Australia Pty Ltd
Quad 2, 6 Parkview Drive
Homebush Bay NSW 2127
Tel: +61 02 9763 4900
Fax: +61 02 9763 7888

ENGINEERING, MANUFACTURING AND SUPPORT CENTERS

Rockford, Illinois USA

5885 11th Street
Rockford, IL 61109 USA
Tel: +1 815 874 5556 Fax:
+1 800 288 7031

UK

Global Technical Assistance, UK
+44 1670 850580