

Parts List for:

4RS302S  
4143  
RSS302

**MODEL B**  
**SINGLE-ACTING, SPRING RETURN**  
**HYDRAULIC CYLINDER**  
Max. Capacity: 32.5 Tons at 10,000 PSI

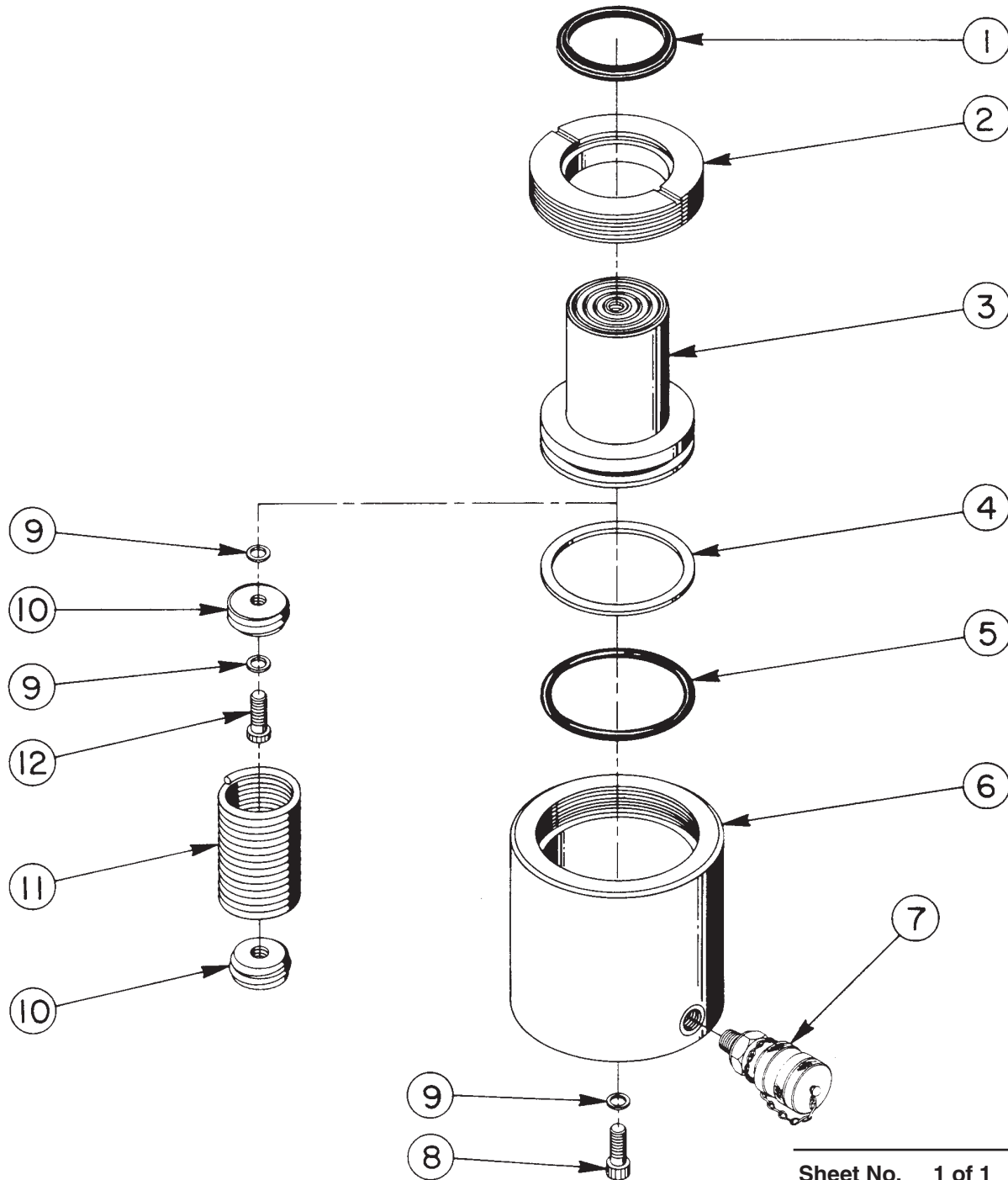

# Parts List, Form No. 100634, Back sheet 1 of 1

Item No.	Part No.	No. Req'd	Description
1	*204969	1	Rod Wiper
2	38963	1	Retainer Nut (Troque to 500/525 in. lbs.)
†3	44790	1	Piston
4	*19151	1	Backup Washer (2-7/8 x 2-1/2 x .070, -333)
5	*11763	1	O-ring (2-7/8 x 2-1/2 x 3/16, -333)
6	44789	1	Cylinder Body
7	9796	1	Ram Half Coupler w/Dust Cap (For RSS302)
	25600-1	1	Ram Half Coupler (For 4143)
	210916	1	Coupler (For 4RS302S)
8	11013	1	Soc. Hd. Cap Screw (5/16-18 UNC x 1" Lg.; Torque to 170/180 in. lbs.)
9	*11031	3	Copper Washer (15/32 x 5/16 x 1/32)
10	306355	2	Spring Retainer
11	212126	1	Extension Spring
12	19253	1	Low Soc. Hd. Cap Screw (5/16-18 UNC x 3/4 Lg.; Torque to 170/180 in. lbs.)
13	9866	1	Dust Cover (For 4143)

### PARTS INCLUDED BUT NOT SHOWN

*203908	1	Warning Decal
212138	1	Trade Name Decal (For 4RS302S)
212139	1	Trade Name Decal (For RSS302)
212140	1	Trade Name Decal (For 4143)

Part numbers marked with an asterisk (\*) are included in Repair Kit No. 300297.

† Note: After April 1991 this piston will no longer be available. It is replaced by conversion kit #300602. This conversion kit consists of the piston, spring, retainers, and screw assembled.

## ASSEMBLY INSTRUCTIONS

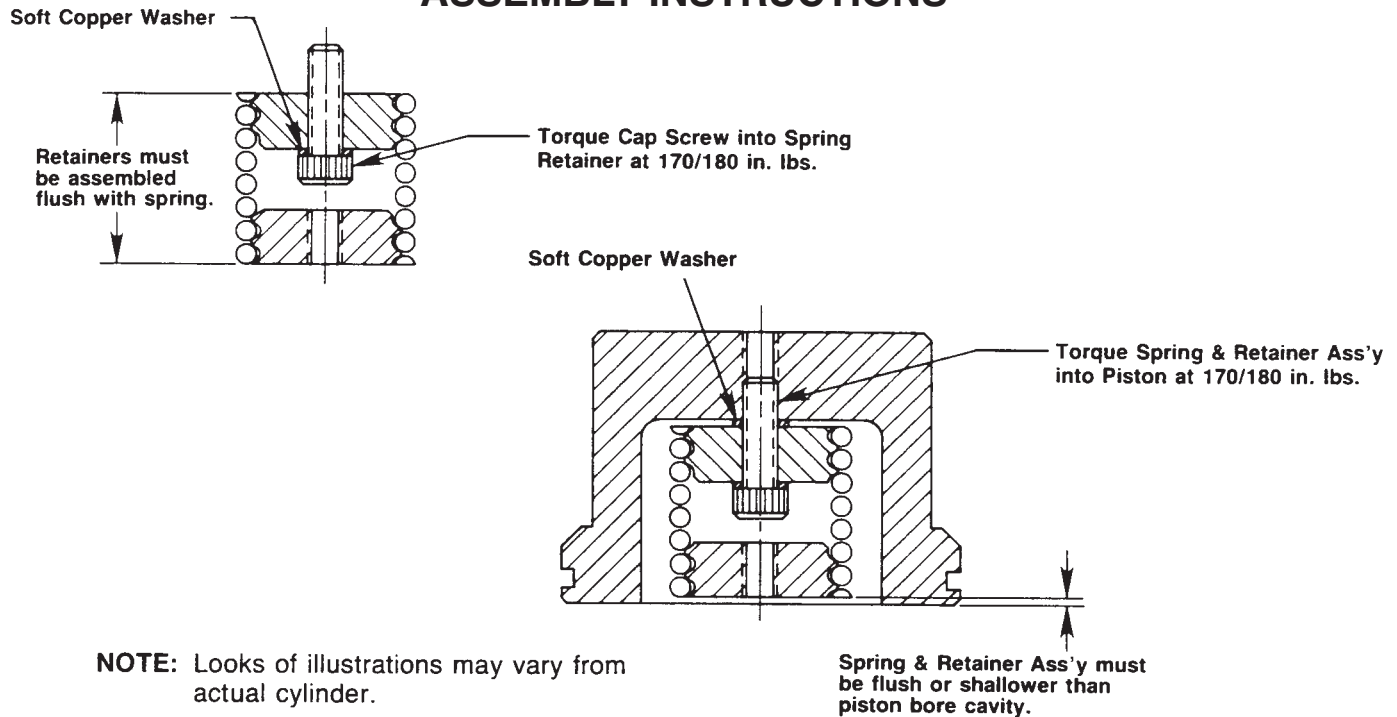

Refer to any operating instructions included with this product for detailed information about operation, testing, assembly, reassembly, and preventive maintenance.

Items found in this parts list have been carefully tested and selected. **Therefore: Use only genuine replacement parts!**

Additional questions can be directed to our Technical Services Department.

Note: Shaded areas reflect last revision(s) made to this form.