

**AIR HYDRAULIC PUMP
AIR MOTOR ASSEMBLY**

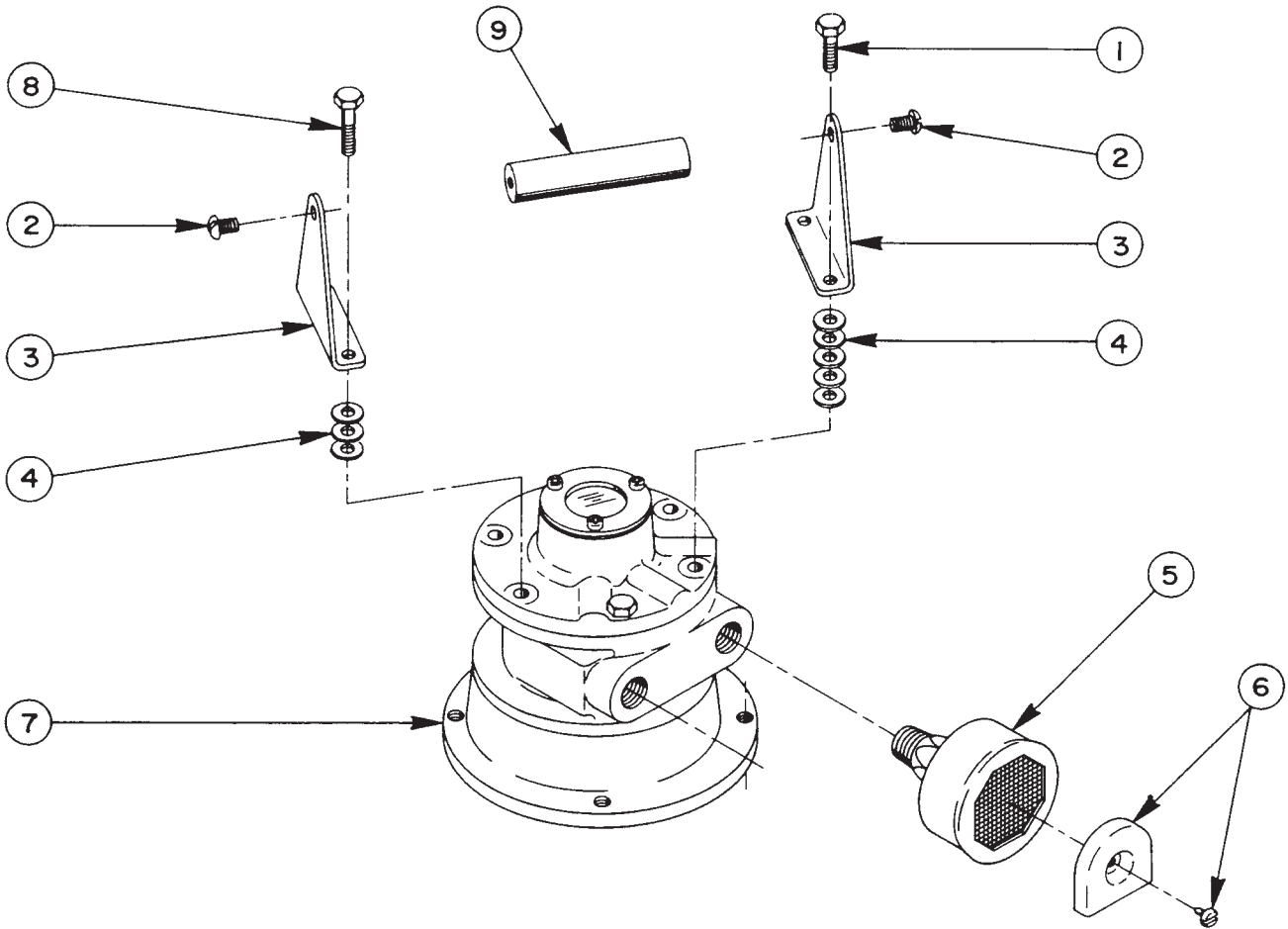

Item No.	Part No.	No. Req'd	Description
1	10014	1	Cap Screw (1/4-28 UNF X 1" Lg.)
2	10174	2	Machine Screw (1/4-20 UNC X 1/2 Lg.)
3	33808	2	Handle Bracket
4	12719	16	Washer (For 1/4 bolt)
5	13966	1	Muffler
6	205505	1	Deflector
7	*14717	1	Air Motor
8	10018	3	Cap Screw (1/4-28 UNF X 1-1/4 Lg.)
9	28158	1	Handle

* Note: For air motor repair kit, order no. 252100.

Item No.	Part No.	No. Req'd	Description
1	308675	1	Mounting Bracket
2	10177	10	Machine Screw (1/4-20 UNC X 3/4 Lg.)
3	208218	6	Straight Fitting
4	10199	2	Nut (1/4-20 UNC)
5	15883	2.3 ft.	Plastic Tubing
6	13229	1	90° Elbow Fitting
7	11421	1	Straight Fitting
8	15378	2	Tee Fitting
9	252653	4	90° Elbow Fitting
10	46843	1	Hose Assembly (25 feet)
11	421265	1	Air Operated Hand Control (See Form #100426)
12	9594	1	Valve Assembly (See Form #108068)
13	9689	2	Straight Fitting
14	13273	2	Plug Fitting (1/4 NPT)
15	47409	1	Cover Plate Gasket (3/16 thick)
16	40063OR9	1	Reservoir
17	214097	1	Key
18	308749	2	Trade Name Decal
19	213674	1	V-ring (Nitrile)
	215438	1	V-ring (Viton)
	251291	1	V-ring (EPR)
20	15187	4	Cap Screw (3/8-16 UNC X 5/8 Lg.; Torque to 90/100 in. lbs.)
21	307425	1	Motor Gasket
22	14794	1	Plastic Cap
23	17636	1	90° Elbow Fitting
24	215639	1	Copper Tubing
25	16494	1	Straight Fitting
26	10479	1	Pipe Plug (1/4 NPTF)
27	10665	1	90° Elbow Fitting
28	212404	1	Air Operated Valve
29	37593	1	Air Manifold Block
30	10022	2	Cap Screw (1/4-20 UNC X 1-1/2 Lg.)
31	212405	1	Shuttle Valve
32	213706	1	Filler Cap
33	251759	1	Instruction Decal (Pump)
34	251760	1	Instruction Decal (Release)

PARTS INCLUDED BUT NOT SHOWN

2000609	1	Drain Tube (Valve)
---------	---	--------------------

Refer to any operating instructions included with this product for detailed information about operation, testing, disassembly, reassembly, and preventive maintenance.

Items found in this parts list have been carefully tested and selected. **Therefore: Use only genuine Power Team replacement parts!**

Additional questions can be directed to our Technical Services Department.

BASIC PUMP ASSEMBLY SIDE VIEW

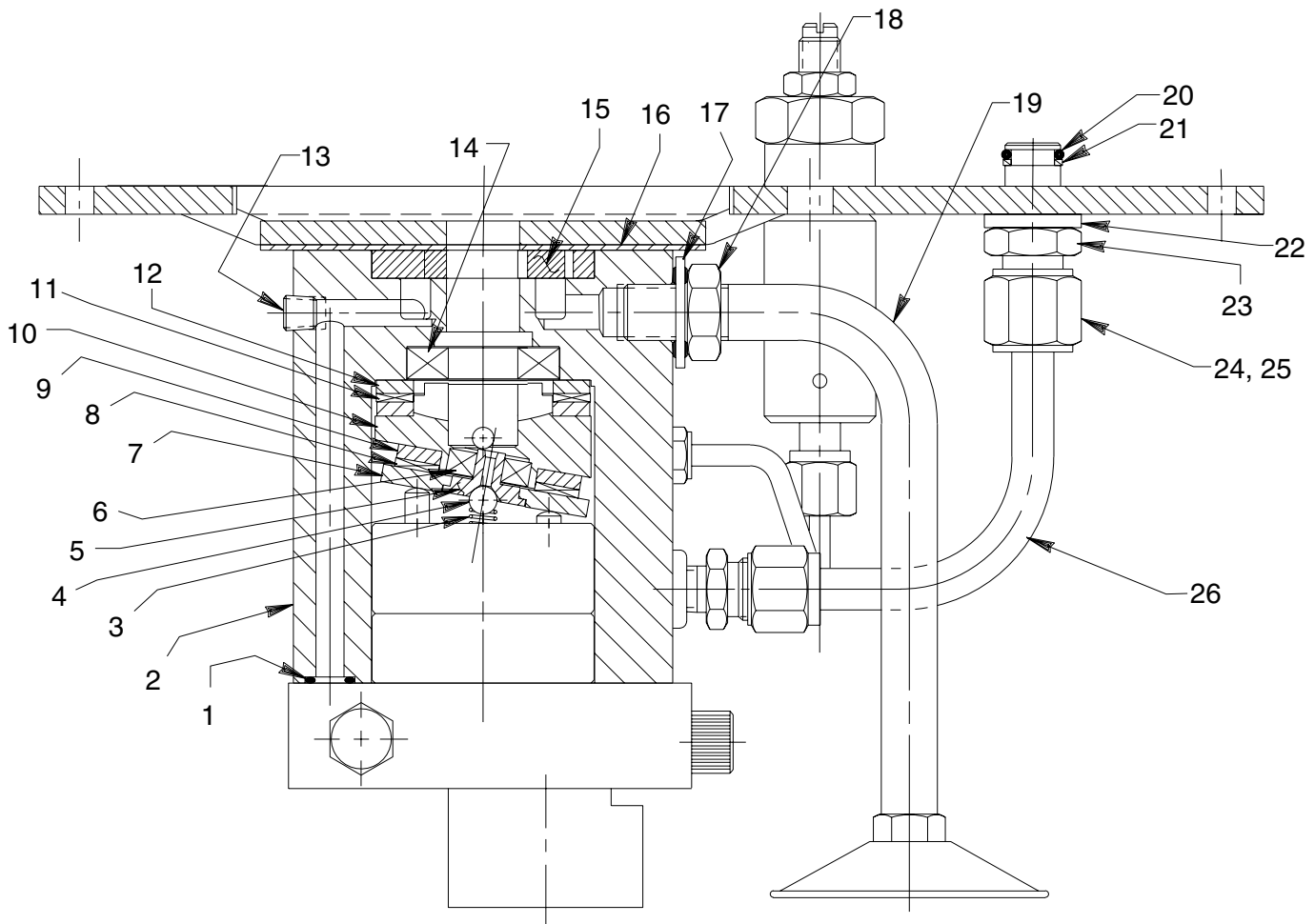

Item No.	Part No.	No. Req'd	Description
1	10267	1	O-ring (7/16 X 5/16 X 1/16; Nitrile)
	18974	1	O-ring (7/16 X 5/16 X 1/16; Viton)
	13472	1	O-ring (7/16 X 5/16 X 1/16; EPR)
2	52883	1	Body
3	16320	1	Compression Spring (1/4 O.D. X 3/4 Lg.)
4	10375	1	Steel Ball (1/4 Dia.)
5	23547	1	Bearing Top Plate
6	11814	1	Ball Bearing
7	23548	1	Top Plate
8	15431	1	Needle Bearing
9	15432	1	Bearing Race
10	35271	1	Angle Plate
11	11228	1	Thrust Bearing
12	11227	2	Bearing Race
13	11084	1	Plug (Torque to 35/45 in. lbs. oiled)
14	15695	1	Ball Bearing
15	15693	1	Gerotor Set

Item No.	Part No.	No. Req'd	Description
16	307296	1	Wear Plate
17	213709	1	Seal Washer (Nitrile)
	215633	1	Seal Washer (Viton)
	215634	1	Seal Washer (EPR)
18	10390	1	Nut (1/2-20 UNF)
19	213686	1	Intake Tube
20	10268	1	O-ring (1/2 X 3/8 X 1/16; Nitrile)
	19775	1	O-ring (1/2 X 3/8 X 1/16; Viton)
	17716	1	O-ring (1/2 X 3/8 X 1/16; EPR)
21	11863	1	Backup Washer (1/2 X 3/8 X 1/16)
22	21484	1	Spacer
23	214882	1	Valve Connector (Note: Torque valve connector [Item #23] to 20/30 ft. lbs. into cover plate. Hold valve connector and torque tube nut [Item #25] to 40/50 ft. lbs.)
24	10430	1	Tube Sleeve
25	10431	1	Tube Nut
26	308614	1	Oil Line Tube

Turn on;
do not
push on.

Note: Shaded areas reflect last revision(s) made to this form.

BASIC PUMP ASSEMBLY BOTTOM VIEW

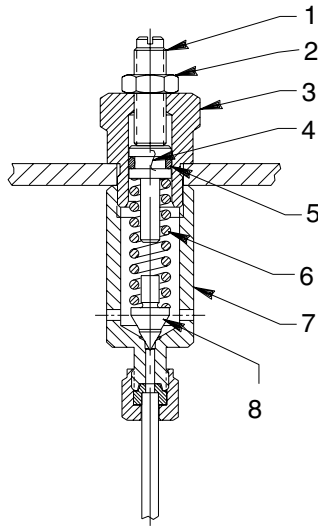

SECTION B-B

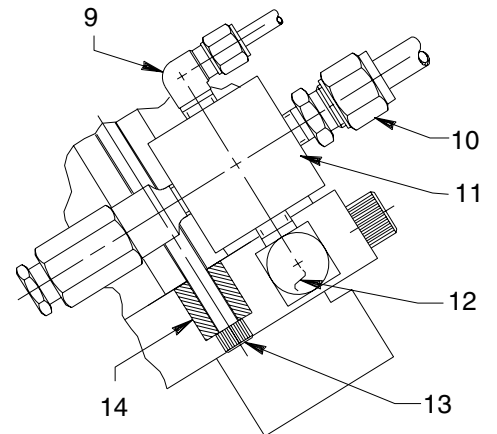

VIEW A-A

Cross torque in 20/30 in. lb. increments in order shown.

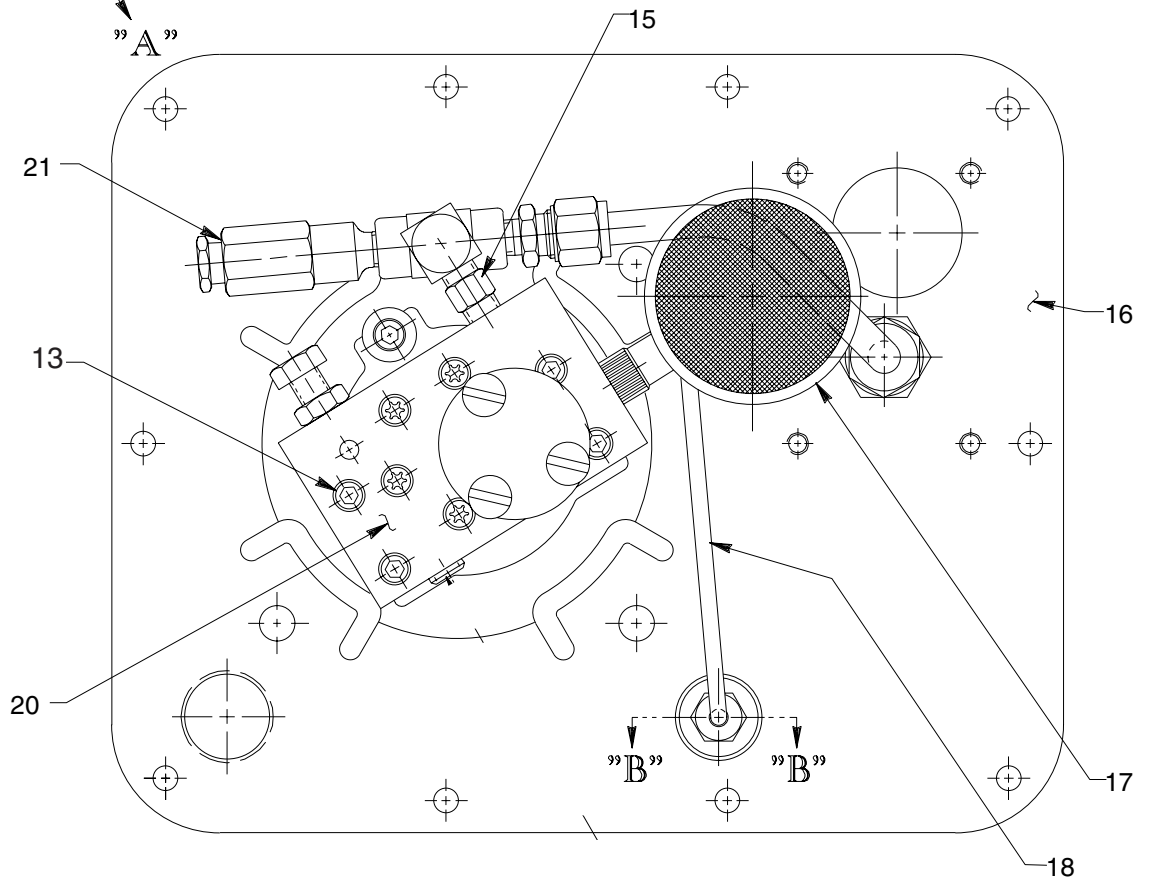
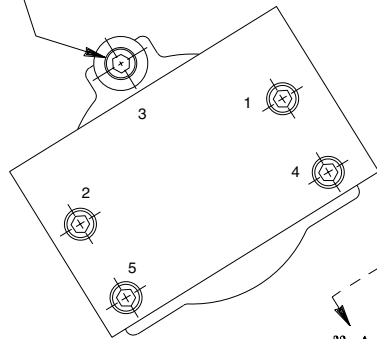

Item No.	Part No.	No. Req'd	Description
1	22362	1	Valve Adjusting Screw
2	10386	1	Nut (3/8-24 UNF)
3	21305	1	Valve Cap
4	21306	1	Spring Guide
5	10268	1	O-ring (1/2 X 3/8 X 1/16; Nitrile)
	19775	1	O-ring (1/2 X 3/8 X 1/16; Viton)
	17716	1	O-ring (1/2 X 3/8 X 1/16; EPR)
6	10495	1	Compression Spring (1/2 O.D. X 1-5/8 Lg.)
7	22361	1	Valve Body
8	21046	1	Valve Stem
9	11278	1	Tube Elbow
10	12696	1	Connector
11	208077	1	Single Cross Fitting
12	24730	1	Elbow
13	15642	5	Cap Screw (1/4-20 X 5" Lg.; Torque to 55/65 in. lbs.)
14	214720	1	Spacer
15	11421	1	Pipe Nipple
16	47404	1	Cover Plate
17	29682	1	Strainer
18	308615	1	Pressure Regulator Tube
20	36925	1	Pump Body Ass'y
21	21278	1	Relief Valve (See Note below)

NOTE

Standard relief valves are set at 10,100/10,700 PSI.
 Relief valves pre-set at special settings are available.
 Refer to your pump model number or contact Power Team Technical Services.

Refer to any operating instructions included with this product for detailed information about operation, testing, disassembly, reassembly, and preventive maintenance.

Items found in this parts list have been carefully tested and selected. **Therefore: Use only genuine Power Team replacement parts!**

Additional questions can be directed to our Technical Services Department.

H. P. PUMP ASSEMBLY - AUTO. VALVE LOW SPEED

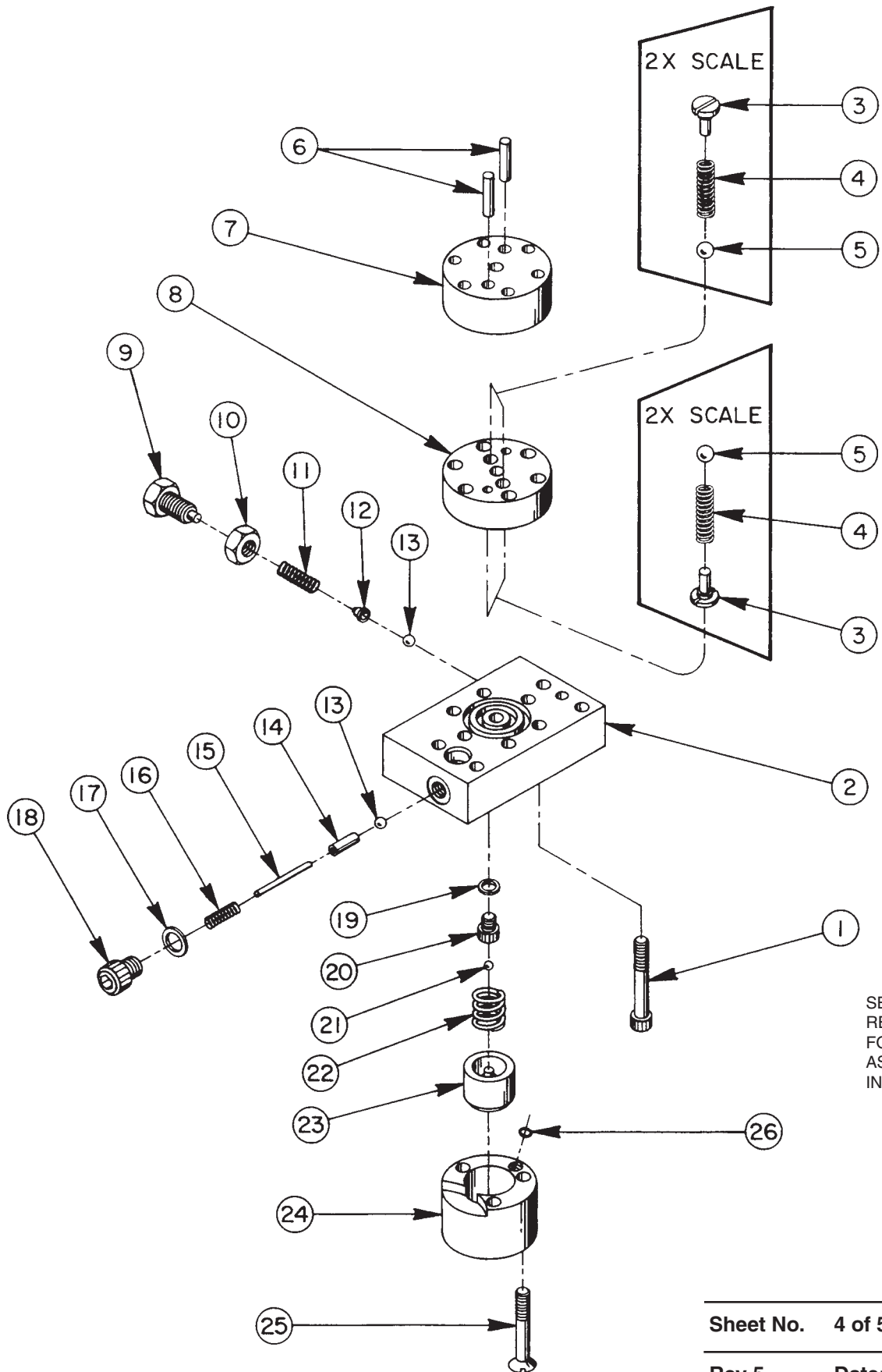

Item No.	Part No.	No. Req'd	Description
1	*16747	7	Torx Drive Cap Screw (1/4-28 X 1-3/4 Lg.; See diagram below)
2	*36911	1	Pump End Plate
3	*24549	4	Valve Guide
4	*10445	4	Compression Spring (3/16 Dia. X 3/4 Lg.)
5	*12223	4	Steel Ball (3/16 Dia.)
6	*20775	2	Piston
7	*41006	1	Pump Barrel
8	*41007	1	Valve Head
9	200797	1	Adjusting Screw
10	10386	1	Jam Nut (3/8-24)
11	15691	1	Compression Spring (1/4 Dia. X 5/8 Lg.)
12	200796	1	Spring & Ball Adapter
13	10375	2	Steel Ball (1/4 Dia.)
14	201998	1	Sleeve
15	12571	1	Roll Pin (1/8 Dia. X 1-3/8 Lg.)
16	15129	1	Compression Spring (3/16 Dia. X 7/8 Lg.)
17	12042	1	Copper Washer Washer (9/16 X 3/8 X 1/32 Thk.)
18	29690	1	Cap Screw (Torque to 180 in. lbs.)
19	10442	1	Copper Washer (3/8 X 1/4 X 1/32 Thk.)
20	201995	1	Cap Screw (Torque to 80/90 in. lbs.)
21	10419	1	Steel Ball (5/32 Dia.)
22	16465	1	Compression Spring
23	202088	1	Piston
24	308613	1	Valve Cylinder
25	214941	3	Rd. Hd. Mach. Screw (1/4-20 X 1-1/2 Lg.)
26	10264	1	O-ring (1/4 X 1/8 X 1/16 CS)

Consult factory when replacing items marked with an asterisk (*).

BOLT TIGHTENING SEQUENCE

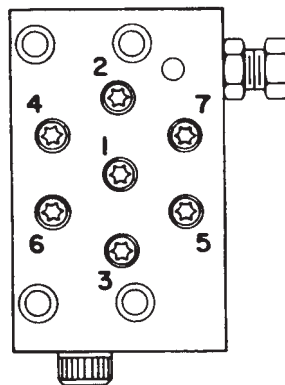

NOTE: Assemble in sequence shown. Lubricate under head and on threads. Torque to 170 in lbs.

HYDRAULIC SCHEMATIC

