

Parts List for:

PE172DC  
PE174DC  
PE174DC-HOL

**MODEL B  
ELECTRIC HYDRAULIC PUMP**

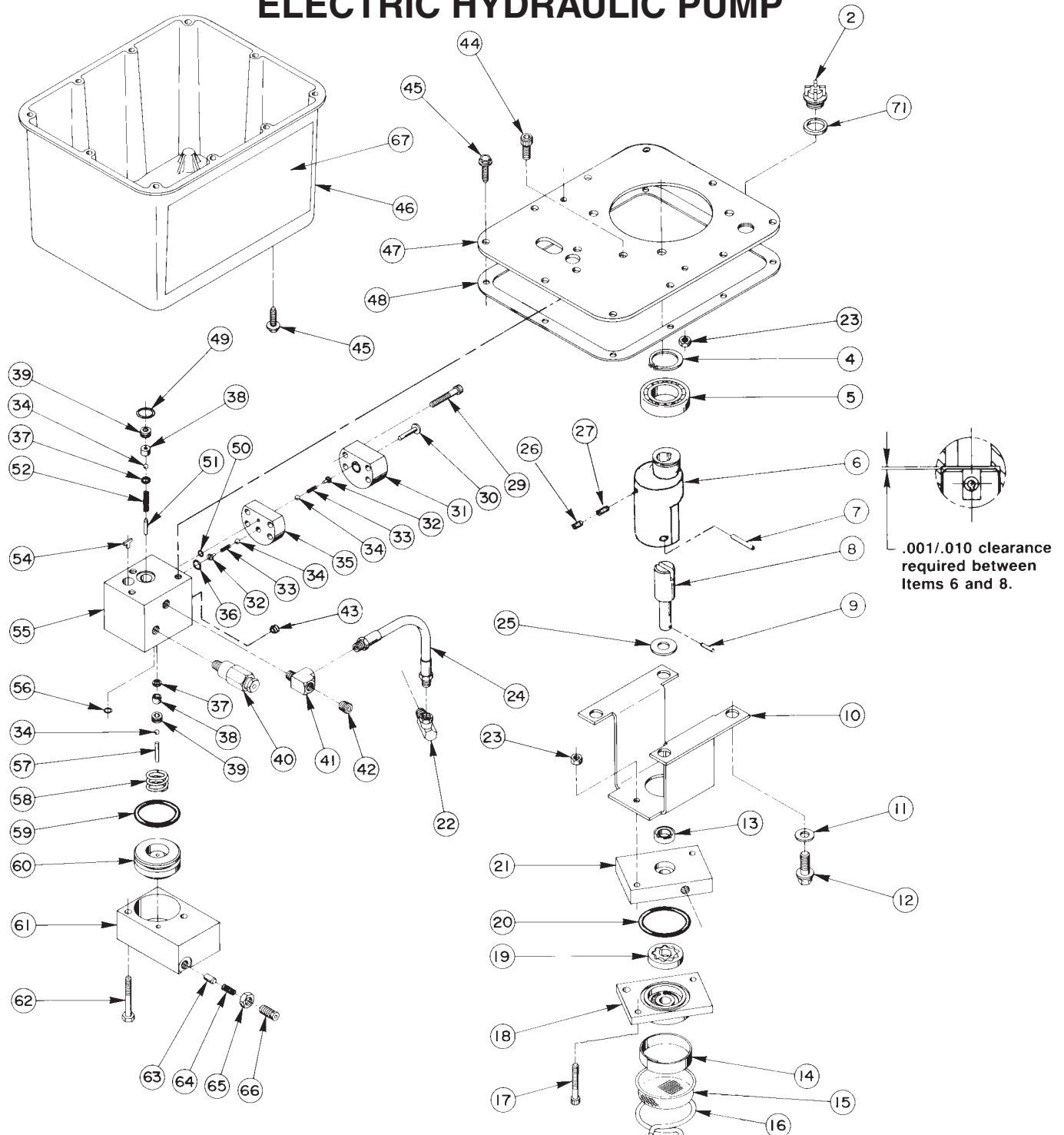

# Parts List, Form No. 100749, Back sheet 1 of 4

Item No.	Part No.	No. Req'd	Description	Item No.	Part No.	No. Req'd	Description
2	20937	1	Filler/Vent Plug	40	21278	1	Relief Valve Assembly (Set at 10,100/10,700 PSI)
	†27142	1	Filler/Vent Plug	41	13229	1	90° Elbow
4	209798	1	Retaining Ring	42	10427	1	Pipe Plug (1/8 NPTF)
5	209805	1	Ball Bearing	43	15130	1	Pipe Plug (1/16 NPTF)
6	45596	1	Eccentric	44	10030	3	Cap Screw (5/16-18 UNC X 3/4 Lg.; Torque to 220/240 in. lbs.)
7	10973	1	Slotted Spring Pin	45	209799	9	Machine Screw (1/4-10 X 7/8 Lg. Self-tapping; Torque to 50/60 in. lbs.)
8	304835	1	Drive Shaft	46	61165	1	Reservoir
9	209794	1	Gerotor Drive Pin	47	61166BK2	1	Cover Plate
10	52174	1	Pump Mounting Bracket	48	*40164	1	Cover Gasket
11	10258	4	Washer (For 3/8 bolt)	49	*10273	1	O-ring (13/16 X 5/8 X 3/32)
12	10048	4	Cap Screw (3/8-16 UNC X 7/8 Lg.; Torque to 230/250 in. lbs.)	†250157	1	O-ring (13/16 X 5/8 X 3/32)	
13	*304830	1	Seal	50	*10265	1	O-ring (5/16 X 3/16 X 1/16)
	†250156	1	Seal	†17714	1	O-ring (5/16 X 3/16 X 1/16)	
14	21846	1	Filter Support	51	12149	1	Dowel Pin
15	21608	1	Filter	52	*16057	1	Compression Spring (3/16 O.D. X 1" Lg.)
16	11461	1	Clamp Ring	54	209795	1	Outlet Ball Stop
17	10854	2	Cap Screw (1/4-20UNC X 1-3/4 Lg.; Torque to 60/80 in. lbs.)	55	61167	1	Check Body
18	61169	1	Lower Gerotor Housing	56	*10266	1	O-ring (3/8 X 1/4 X 1/16)
19	304826	1	Gerotor Set	†17715	1	O-ring (3/8 X 1/4 X 1/16)	
20	*10922	1	O-ring (2-1/8 X 1-15/16 X 3/32)	57	211843	1	Dowel Pin (Loctite pin in piston hole with radius end out)
	†250158	1	O-ring (2-1/8 X 1-15/16 X 3/32)	58	*16346	1	Compression Spring (1" O.D. X 7/8 Lg.)
21	61170	1	Upper Gerotor Housing	59	*10283	1	O-ring (2" X 1-5/8 X 3/16)
22	14440	1	Swivel Elbow Fitting	†250159	1	O-ring (2" X 1-5/8 X 3/16)	
23	10199	2	Nut (1/4-20 UNC)	60	46063	1	Automatic Valve Piston
24	304819	1	Hose Assembly	61	52167	1	Automatic Valve Block
25	12595	1	Brass Washer (1-1/8 X 1/2 X .077 Thk.)	62	13037	2	Cap Screw (1/4-20 UNC X 2" Lg.; Torque to 40/50 in. lbs.)
26	10519	1	Set Screw (1/4-20 UNC X 3/8 Lg.; Torque to 60/80 in. lbs.)	63	15156	1	Dowel Pin (Install tapered end toward spring)
27	10136	1	Set Screw (1/4-20 UNC X 1/4 Lg.; Torque to 60/80 in. lbs.)	64	*15691	1	Compression Spring (1/4 O.D. X 5/8 Lg.)
29	10022	4	Cap Screw (1/4-20 UNC X 1-1/2 Lg.; Torque to 180/200 in. lbs.)	65	10386	1	Locknut (3/8-24 UNF)
30	304820	1	High Pressure Piston	66	29786	1	Adjusting Screw
31	45560	1	Piston Block	67	304841	2	Trade Name Decal
32	24549	2	Valve Guide	71	200415	1	Rubber Seal
33	*10445	2	Compression Spring (5/32 O.D. X 3/4 Lg.)	†17723	1	Rubber Seal	
34	*12223	4	Ball (3/16 Dia.)	<b>PARTS INCLUDED BUT NOT SHOWN</b>			
35	45559	1	Check Block	†11278	1	Tube Elbow	
36	*14763	1	O-ring (7/16 X 5/16 X 1/16)	†15060	1	Male Connector	
	†13472	1	O-ring (7/16 X 5/16 X 1/16)	†251229	1	Oil Line	
37	*10442	2	Copper Washer (3/8 X 1/4 X 1/32)	†250328	1	Decal (EPR Seals)	
38	*209787	2	Replaceable Seat				
39	209797	2	Hollow Lock Screw (7/16-20 UNF- 3A; Torque to 180/200 in. lbs.)				

Part numbers marked with an asterisk (\*) are contained in Repair Kit No. 300430.  
Part numbers marked with a dagger (†) are contained in EPR Seal Kit No. 300648.

TOP VIEW

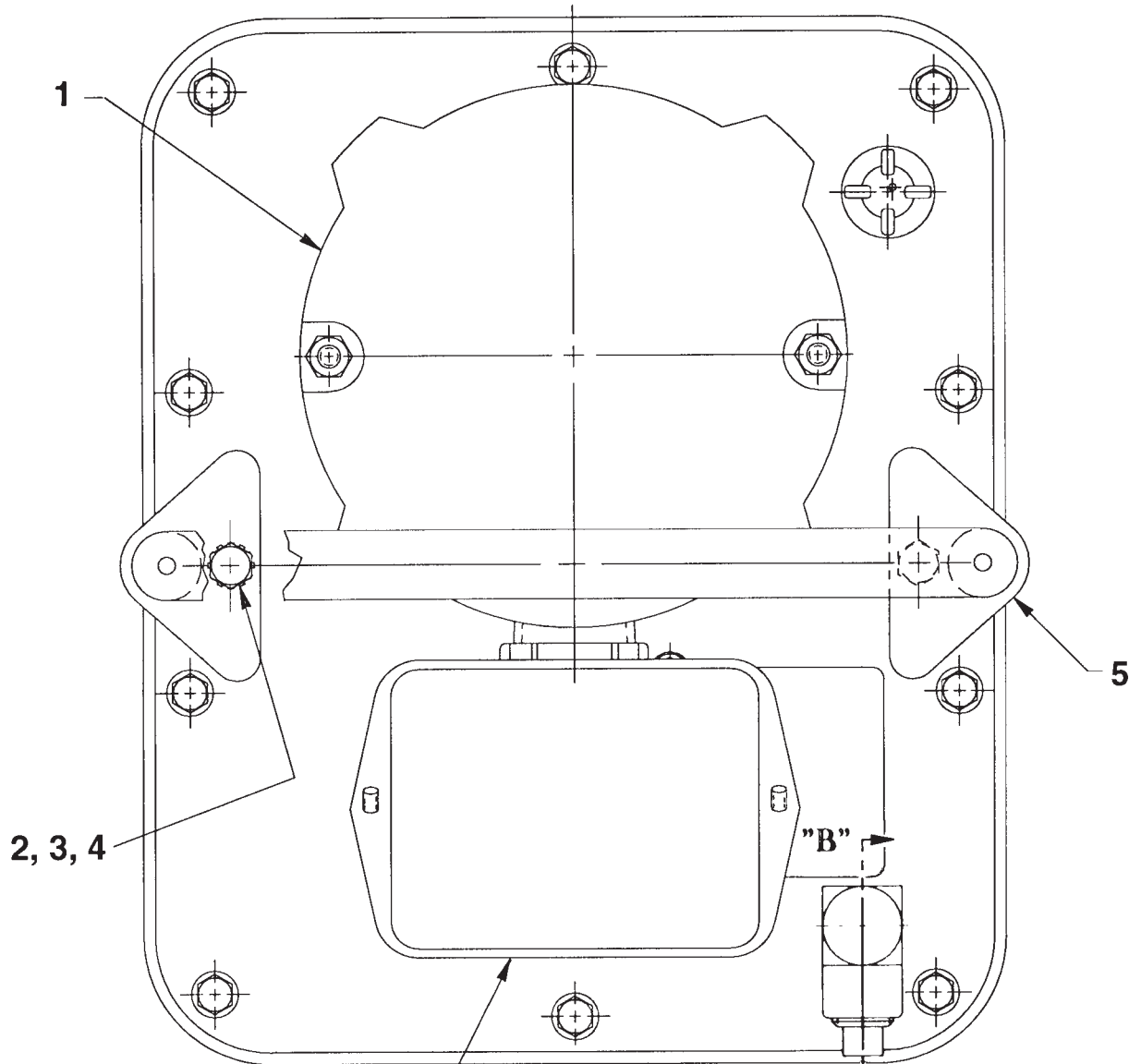

Electrical Control Assembly  
See sheet 3 of 4

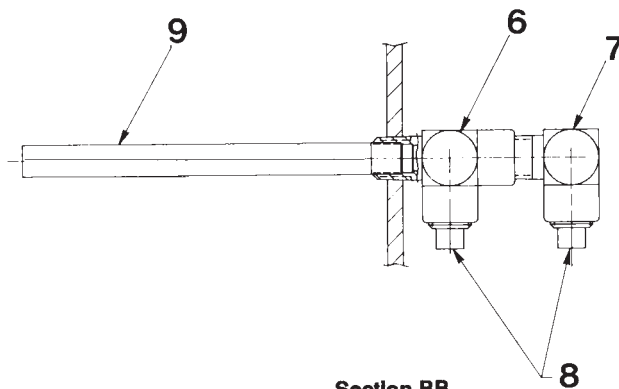

Section BB  
(For PE174-DC-HOL only)

Item No.	Part No.	No. Req'd	Description
1	52384	1	Electric D.C. Motor
2	12825	2	Cap Screw (1/4-20 x 5/8 Lg.)
3	10245	2	Washer (For 1/4 bolt)
4	10199	2	Hex Nut (1/4-20)
5	47492	1	Handle
6	209230	1	Tee Fitting (For PE174-DC-HOL)
7	9681	1	90° Elbow Fitting (For PE174DC-HOL only)
8	11036	2	Plug (3/8 NPTF; For PE174DC-HOL only)
9	200609	1	Drain Tube (For PE174DC-HOL only)

### HYDRAULIC SCHEMATIC

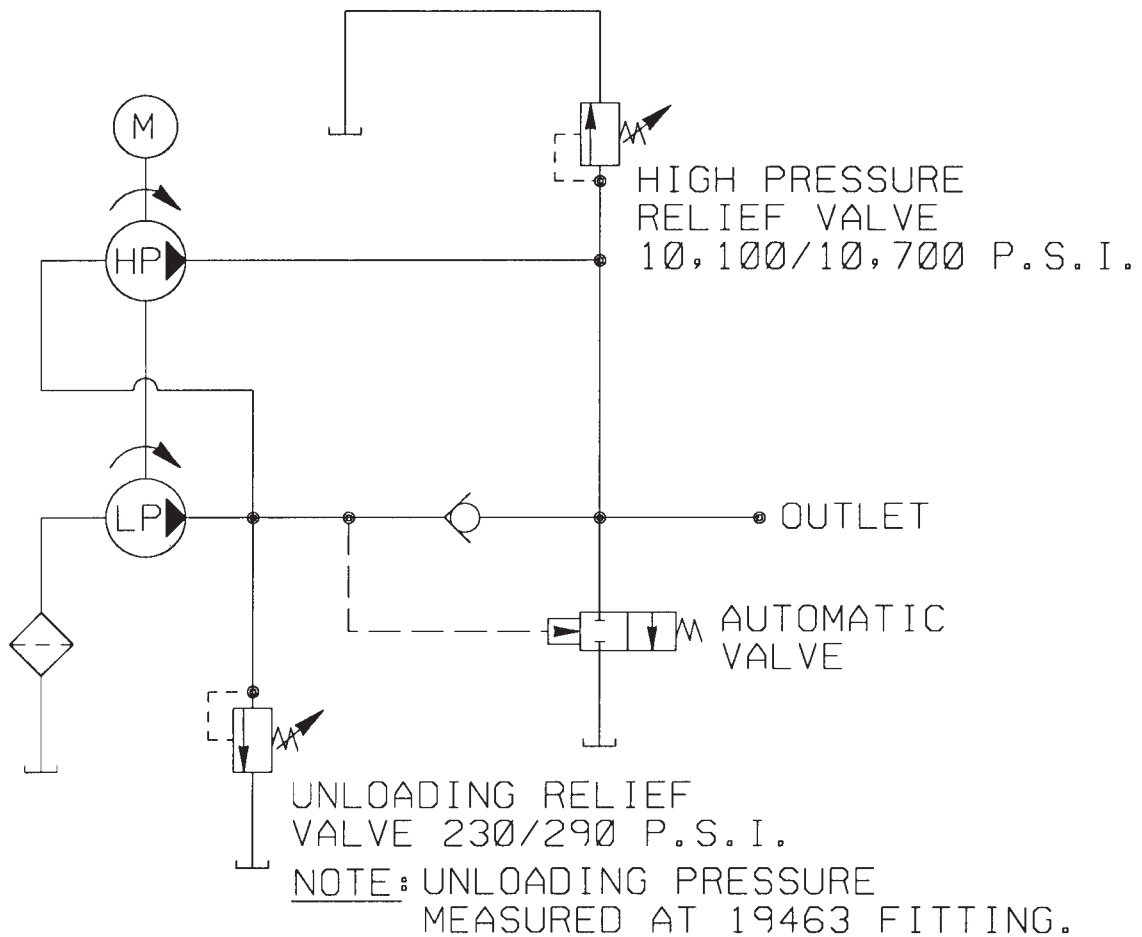

# ELECTRICAL CONTROL ASSEMBLY

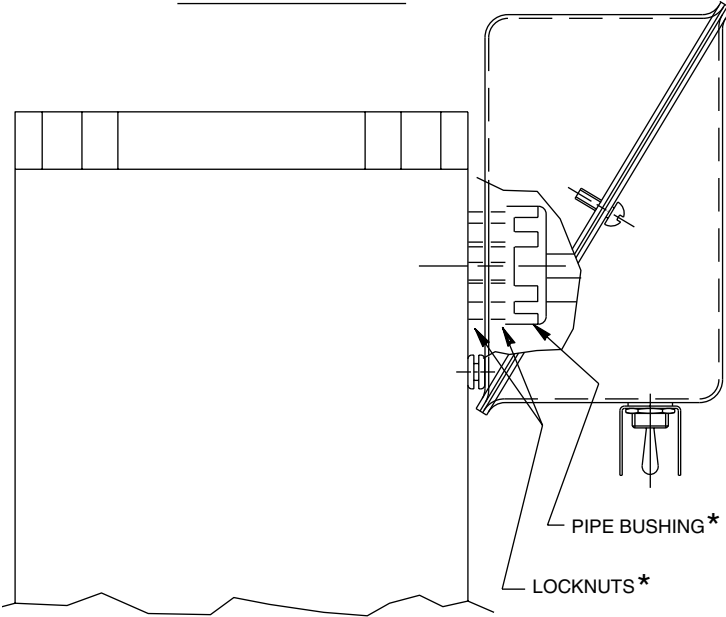
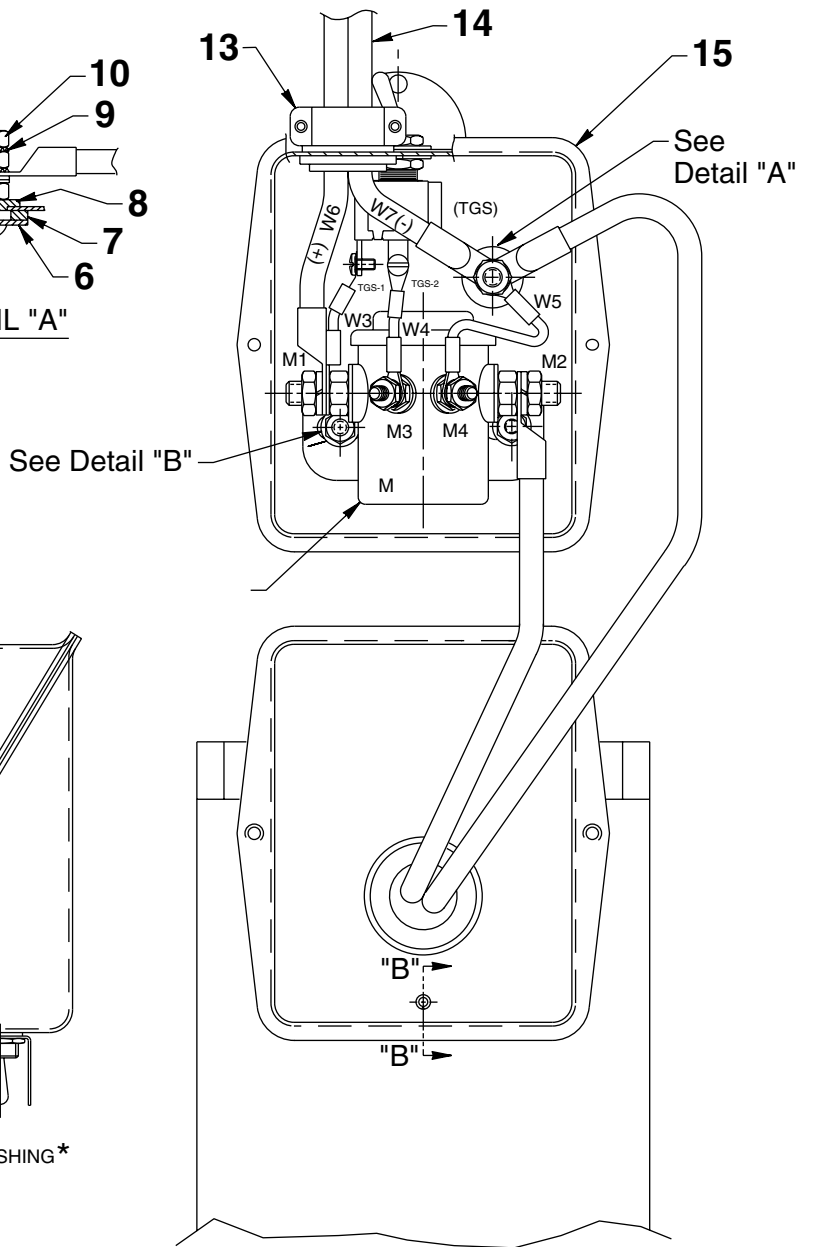
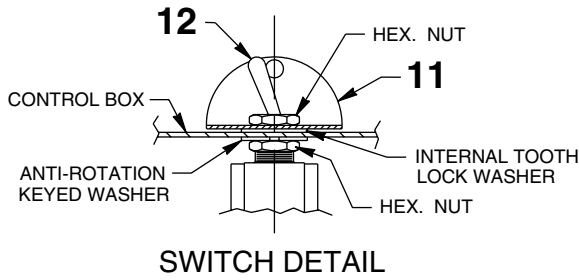
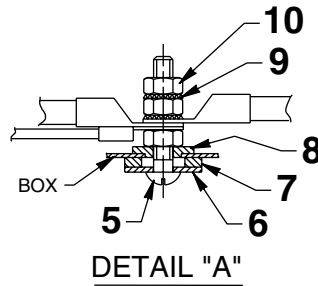
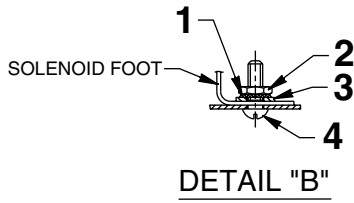

\* INCLUDED WITH ELECTRIC MOTOR

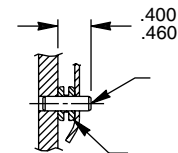

**WARNING**

To help avoid personal injury, all electrical work must be done by a qualified electrician.

**North American & International Color Codes**

Conductors	North American	International
Line .....	Black	Brown
Neutral .....	White	Blue
Ground .....	Green	Green/Yellow

Item No.	Part No.	No. Req'd	Description
1	11108	2	Lockwasher (#10 External Tooth)
2	10197	2	Nut (#10-24 UNC)
3	11089	2	Washer (#10 bolt)
4	12354	2	Machine Screw (10-24 UNC X 5/8 Lg.)
5	10614	1	Machine Screw (1/4-20 UNC X 1-1/2 Lg.)
6	17160	1	Special Washer
7	251384	1	Rubber Bushing
8	202614	1	Nylon Seal
9	11351	2	Lockwasher (1/4 External Tooth)
10	10199	3	Nut (1/4-20 UNC)
11	352061	1	Switch Guard
12	12301	1	Toggle Switch
13	211240	1	Conduit Connector
14	306972	1	Battery Cable
15	47810	1	Control Box (NOTE: Includes box, cover, and two screws.)

**PARTS INCLUDED BUT NOT SHOWN**

13890	1	Indicator Switch Plate
-------	---	------------------------

**ELECTRICAL SCHEMATIC**

12 V.D.C.

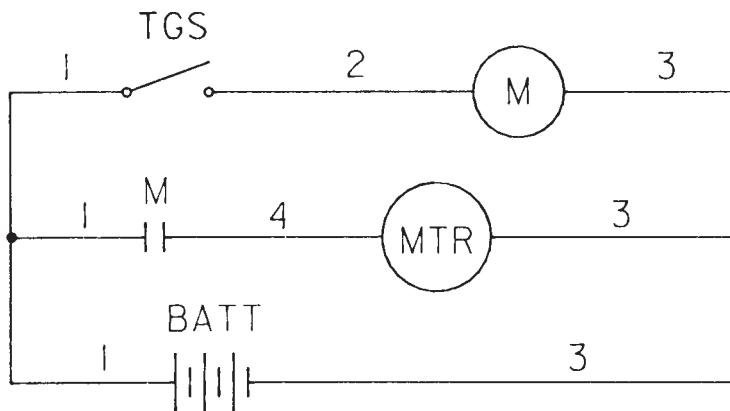

Note: Shaded areas reflect last revision(s) made to this form.

## TWO POSITION, 2-WAY MANUAL VALVE (FOR PE172DC)

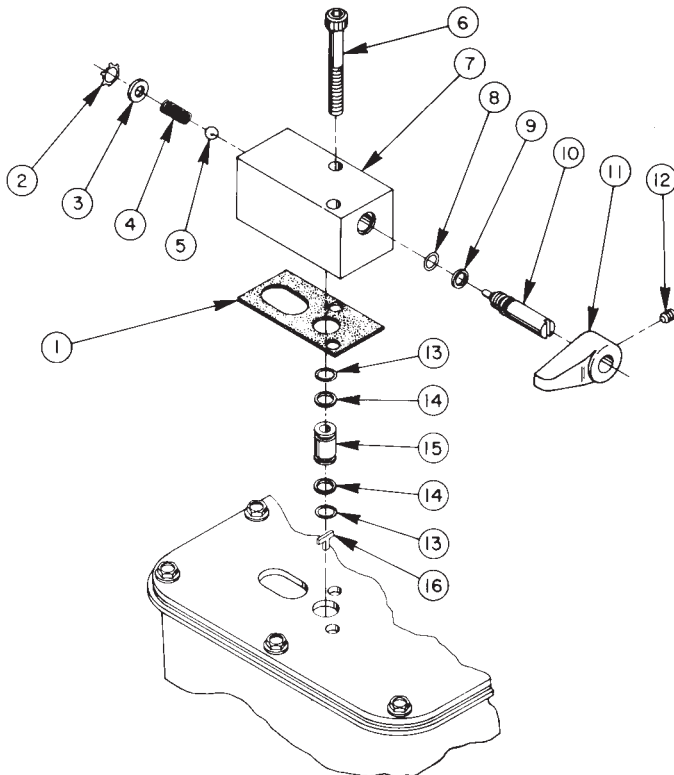

Item No.	Part No.	No. Req'd	Description
1	*304829	1	Gasket
2	*11088	1	Retaining Ring
3	11089	1	Washer (#10 bolt)
4	*11024	1	Compression Spring (1/4 O.D. X 5/8 Lg.)
5	*10375	1	Steel Ball (1/4 Dia.)
6	209945	2	Cap Screw (5/16-18 UNC X 2-1/2 Lg.; Torque to 220/240 in. lbs.)
7	52168	1	Valve Body
8	*10267	1	O-ring (7/16 X 5/16 X 1/16)
	†13472	1	O-ring (7/16 X 5/16 X 1/16)
9	*15085	1	Backup Washer (7/16 X 5/16 X 3/64 Thk.)
10	304849	1	Release Valve Screw
11	213109	1	Knob
12	10556	1	Set Screw (1/4-20 UNC X 1/4 Lg.)
13	*10268	2	O-ring (1/2 X 3/8 X 1/16)
	†17716	2	O-ring (1/2 X 3/8 X 1/16)
14	*11863	2	Backup Washer (1/2 X 3/8 X 1/16)
15	202505	1	Coupling
16	209795	1	Outlet Ball Stop (Part of the Basic Pump Assembly)
	52170	1	Complete Valve Assembly (Consists of items 1 through 15)

Part numbers marked with an asterisk (\*) are contained in Repair Kit No. 300430.  
Part numbers marked with a dagger (†) are contained in EPR Seal Kit No. 300648.

Refer to any operating instructions included with this product for detailed information about operation, testing, disassembly, reassembly, and preventive maintenance.

Items found in this parts list have been carefully tested and selected. **Therefore: Use only genuine Power Team replacement parts!**

Additional questions can be directed to our Technical Services Department.

## 4-WAY TANDEM CENTER DIRECTIONAL VALVE (FOR PE174DC & PE174DC-HOL)

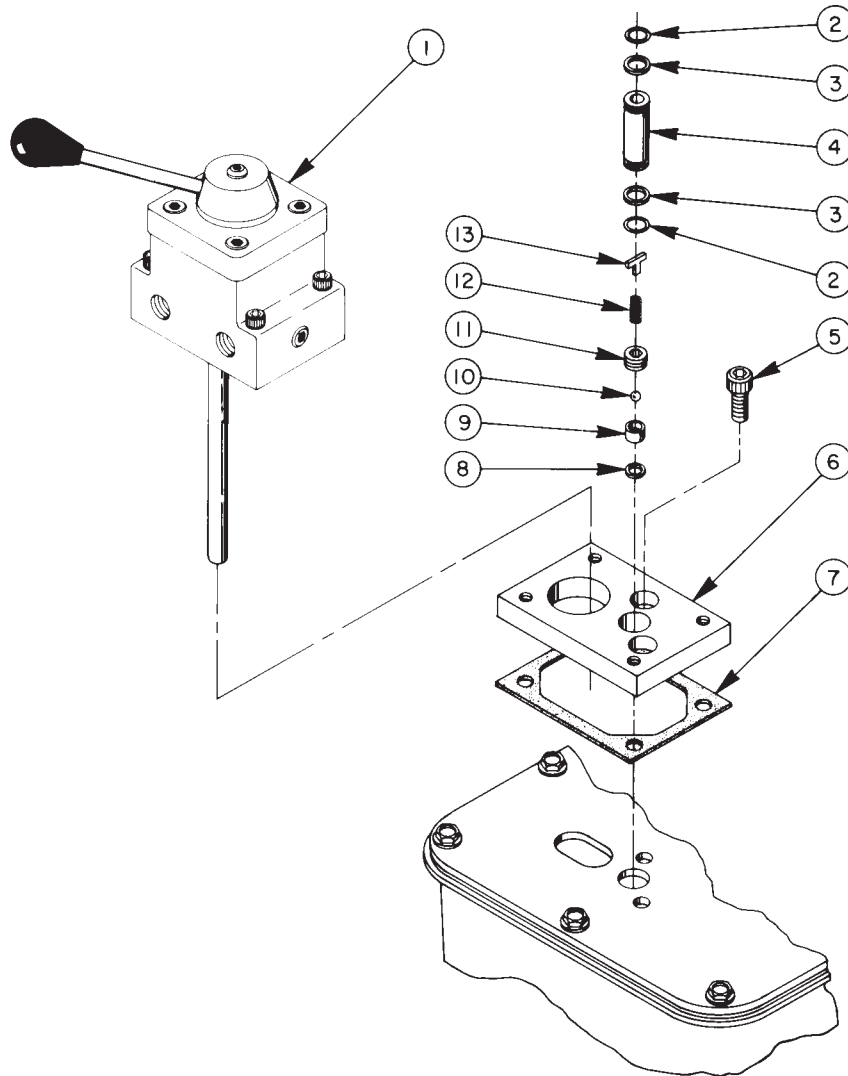

Item No.	Part No.	No. Req'd	Description
1	9586	1	4-Way Valve Assembly (See Form No. 100388)
2	†*10268	2	O-ring (1/2 X 3/8 X 1/16)
	†17716	2	O-ring (1/2 X 3/8 X 1/16)
3	†*11863	2	Backup Washer (1/2 X 3/8 X 1/16)
4	209809	1	Coupling
5	10030	2	Cap Screw (5/16-18 UNC X 3/4 Lg.; Torque to 220/240 in. lbs.)
6	52165	1	Adapter Block Manifold

Item No.	Part No.	No. Req'd	Description
7	*200395	1	Gasket
8	†*10442	1	Copper Washer (3/8 X 1/4 X 1/32)
9	†*209787	1	Replaceable Seat
10	†*12223	1	Steel Ball (3/16 Dia.)
11	209797	1	Hollow Lock Screw (7/16-20 UNF-3A; Torque to 110/130 in. lbs.)
12	211797	1	Compression Spring (5/32 O.D. X 5/8 Lg.)
13	†209795	1	Outlet Ball Stop

Part numbers marked with an asterisk (\*) are contained in Repair Kit No. 300430  
 Part numbers marked with a dagger (†) are contained in Repair Kit No. 300606.