

Parts List for:

9526
9556
9559

**2-POSITION, 3-WAY --- SOLENOID CONTROLLED
DIRECTIONAL VALVE**

Max. Capacity: 10,000 PSI

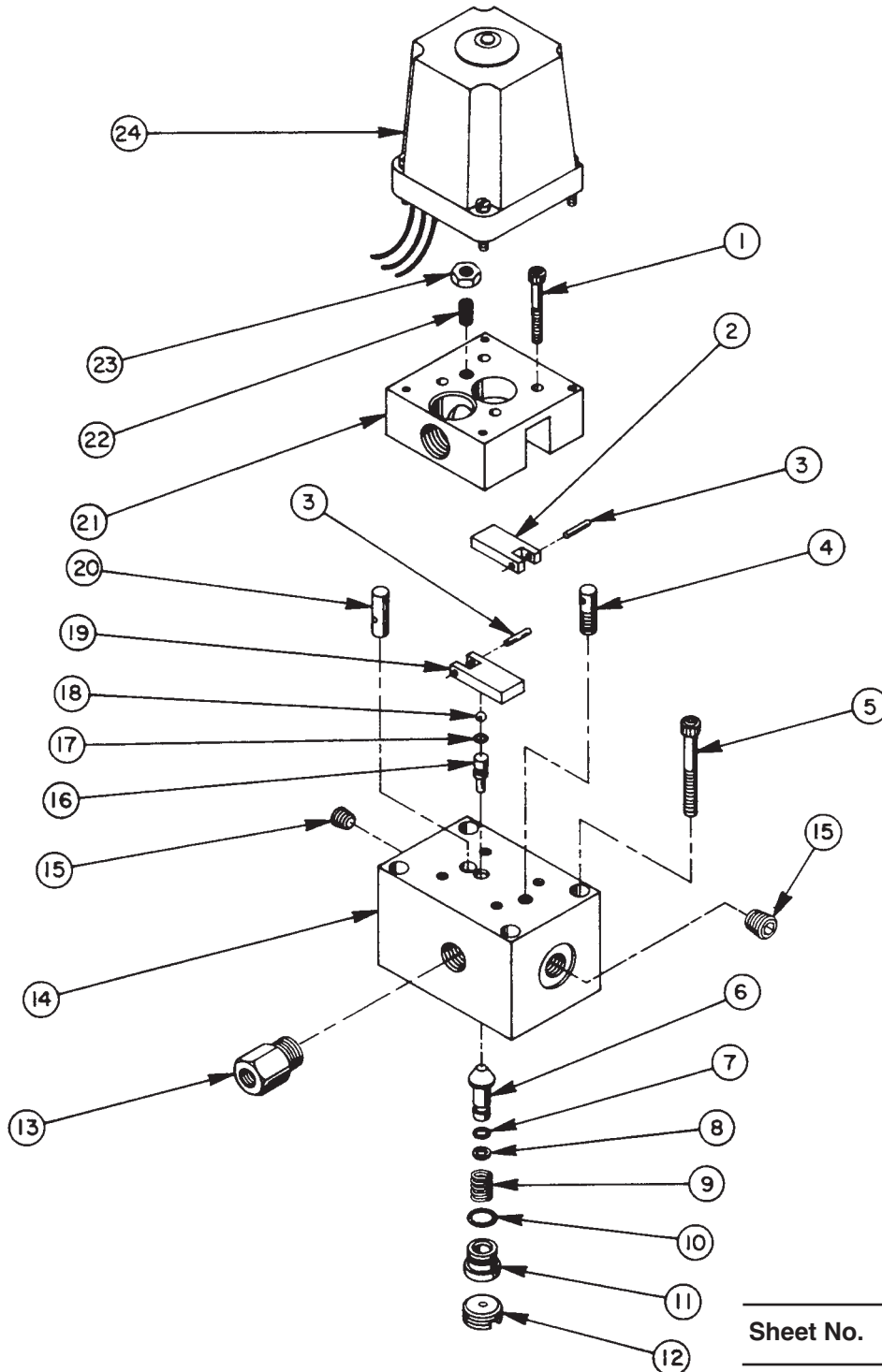

Sheet No. 1 of 2

Rev. 4 Date: 15 July 2008

Parts List, Form No. 100802, Back sheet 1 of 2

Item No.	Part No.	No. Req'd	Description
1	12650	4	Soc. Hd. Cap Screw (#10-24 UNC x 1-1/2 Lg.; Torque to 35/40 in. lbs.)
2	203102	1	Lever (Upper)
3	17026	2	Dowel Pin (1/8 dia. x 5/8 Lg.)
4	203100	1	Threaded Pin
5	10890	4	Soc. Hd. Cap Screw (1/4-20 x 2" Lg.)
6	203106	1	Poppet
7	*10265	1	O-ring (5/16 x 3/16 x 1/16)
8	*15174	1	Backup Washer (5/16 x 3/16 x 3/64)
9	17033	1	Compression Spring (5/16 I.D. x 5/8 Lg.)
10	*15292	1	O-ring (9/16 x 7/16 x 1/16)
11	350004	1	Guide
12	250004	1	Special Jam Screw (Torque to 225/250 in. lbs.)
13	309231	1	Metering Valve
14	58003	1	Valve Body
15	11127	2	Pipe Plug (3/8 NPTF)
16	203104	1	Stem
17	*10264	1	O-ring (1/4 x 1/8 x 1/16)
18	12223	1	Ball (3/16 dia.)
19	203103	1	Lever (Lower)
20	203101	1	Pin
21	421452	1	Linkage Block
22	10138	1	Set Screw (1/4-20 UNC x 5/8 Lg.)
23	10199	1	Nut (1/4-20 UNC)
24	17027-1	1	Solenoid (115 V., 50/60 Hz.)
	17027-2	1	Solenoid (220 V., 50/60 Hz.)
	306560	1	Solenoid (24 V., 50/60 Hz.)

PARTS INCLUDED BUT NOT SHOWN

250014	1	Trade Name Decal
--------	---	------------------

Part numbers marked with an asterisk (*) are contained in Repair Kit No. 300489.

ADVANCE, HOLD, RETURN SPECIFICATIONS

This is a remote-mounted, solenoid-operated, 2-position, 3-way valve. The valve has "advance" and "return" positions.

Advance: By running pump with solenoid de-energized. (Pump flow enters and goes directly to the cylinder port.)

Hold: Work is held when pump is stopped with solenoid de-energized. (Oil is held at outlet check in pump and at release poppet check in the valve.)

Return: Oil is directed back to tank by energizing the solenoid. (Release poppet opens through a force multiplying linkage.)

J.I.C. SYMBOL

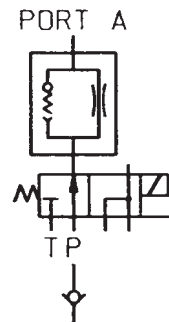

Note: For leakproof operation this valve should be used with a check valve located in the pressure line from pump unit.

Refer to any operating instructions included with the product for detailed information about operation, disassembly, and preventive maintenance.

Items found in this parts list have been carefully tested and selected. **Therefore: Use only genuine Power Team replacement parts!**

Additional questions can be directed to one of our Technical Services Departments.

SECTION A-A SPECIFICATIONS

Solenoid Leads
 Black Wire - Common
 Yellow Wire - 50 Hz.
 Red Wire - 60 Hz.

Note: Cap unused lead.

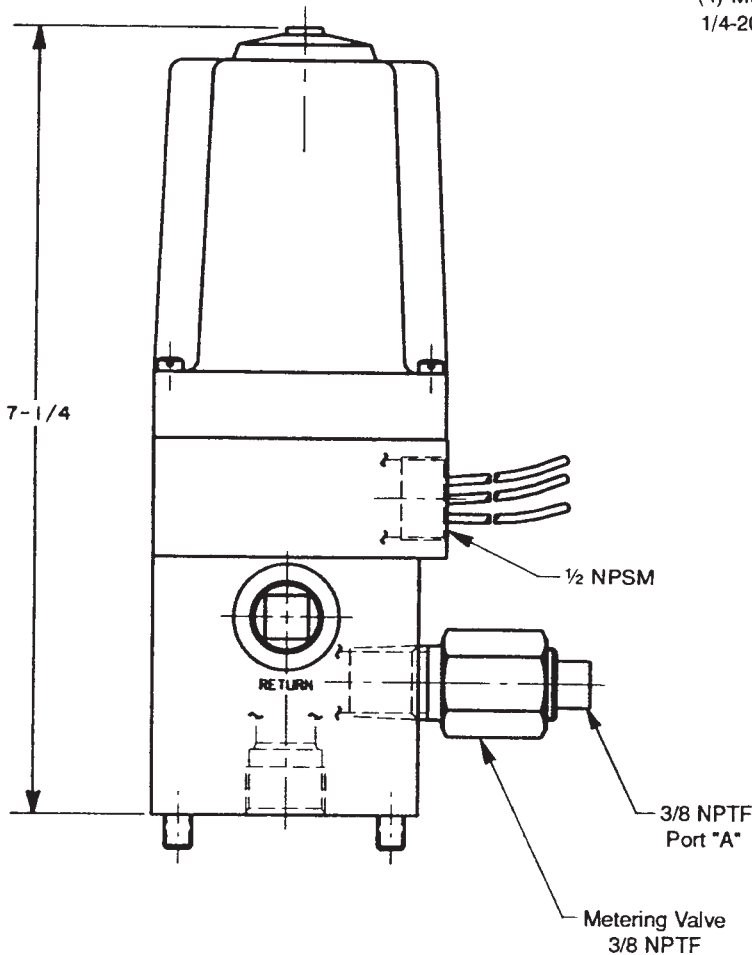
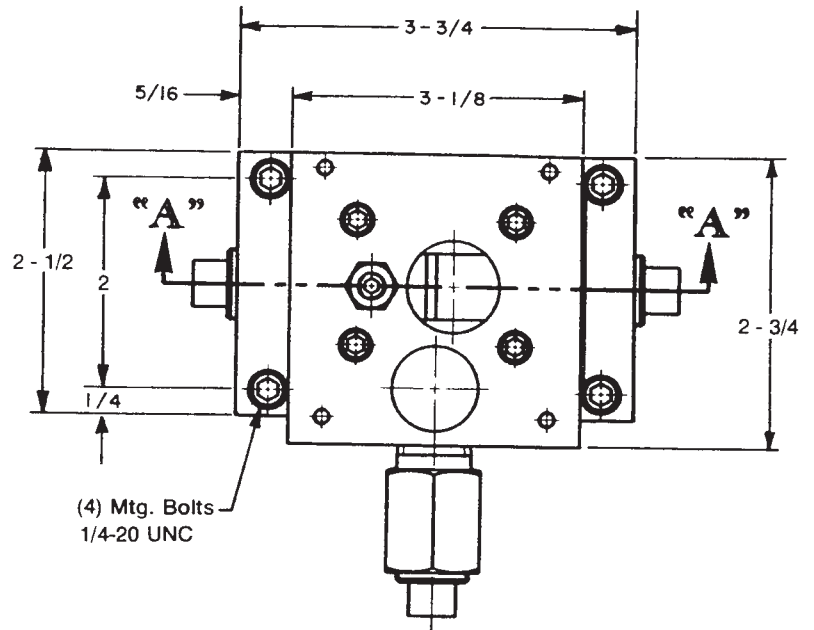

Assemble with Permabond No. 240 rapid bond or equivalent. Note: Force ball to bottom of drilled hole when bonding.

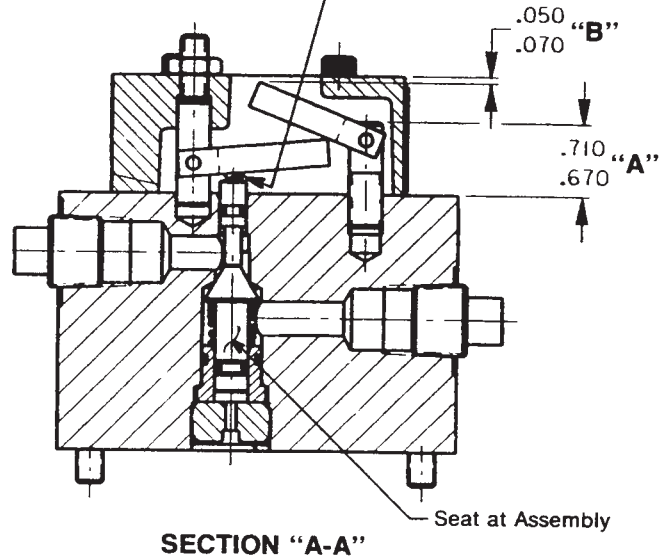

IMPORTANT:

Linkage Adjustment

1. Adjust pin #203100 (Item no. 4) to dim. "A".
2. Adjust set screw #10138 (Item no. 22) until upper lever #203102 (Item no. 2) is at dim. "B".
3. Lock in position with nut #10199 (Item no. 23).