

MODEL B ELECTRIC TWO-STAGE HYDRAULIC PUMP

GENERAL SECTION

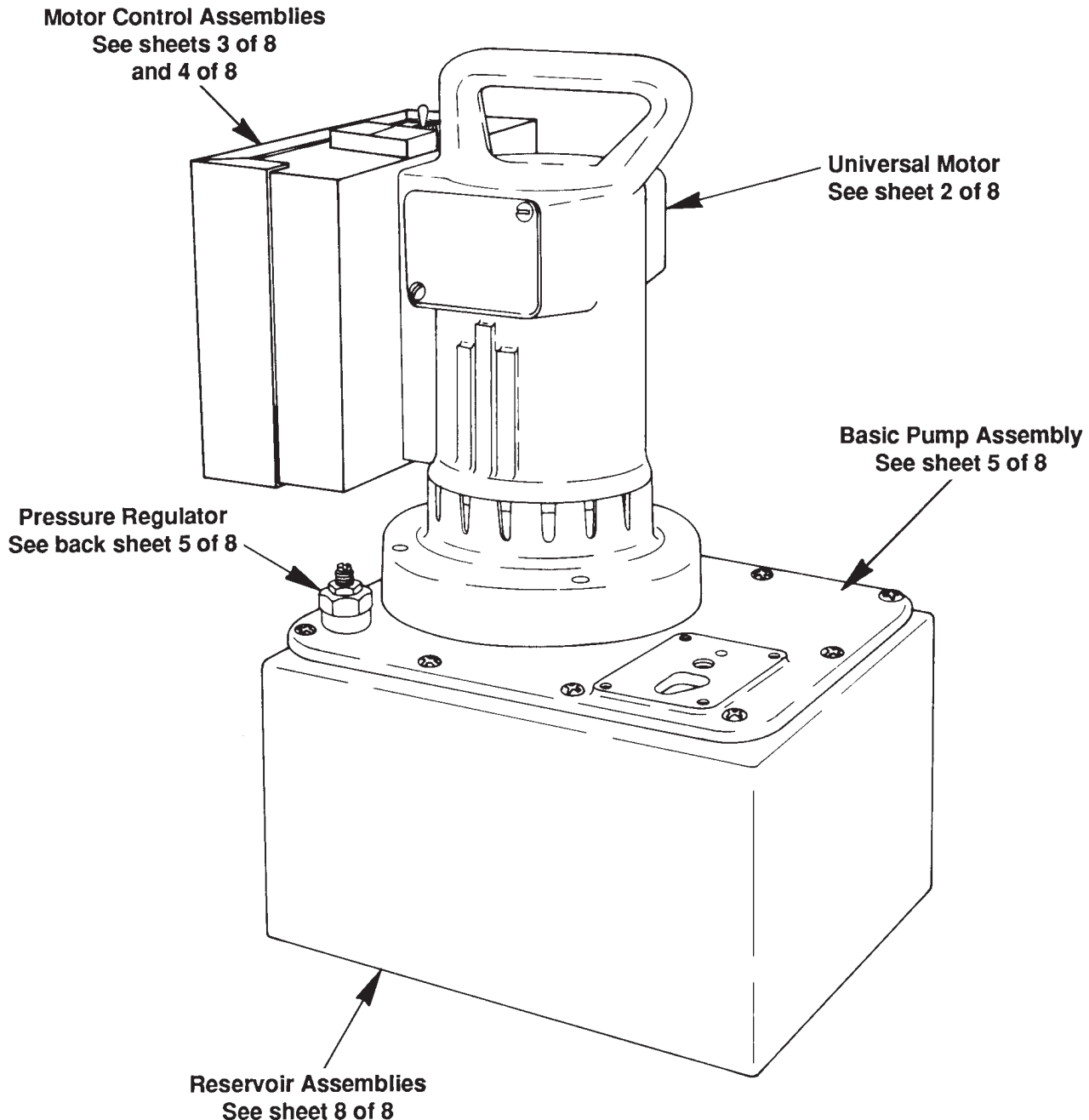

ELECTRICAL SCHEMATICS

NOTE: These schematics are only for standard pumps. Special applications may require different schematics that are not shown here.



WARNING

To help avoid personal injury, all electrical work must be done by a qualified electrician.

North American & International Color Codes

Conductors	North American	International
Line	Black	Brown
Neutral	White	Blue
Ground	Green	Green/Yellow

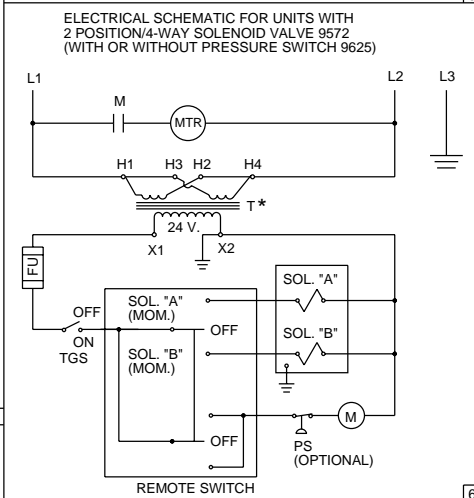
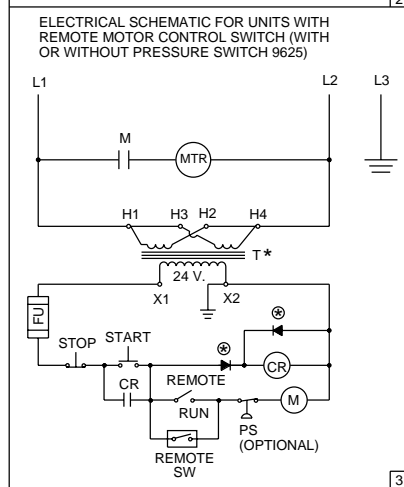
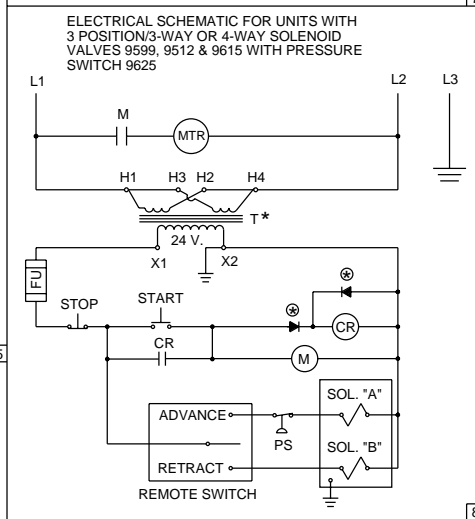
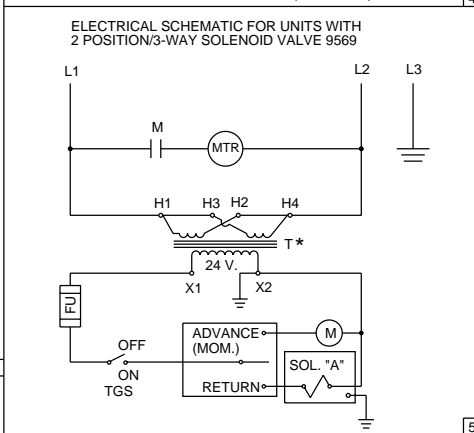
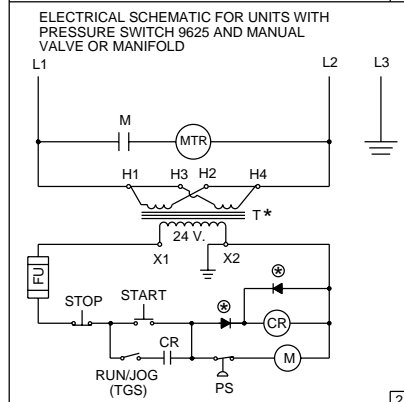
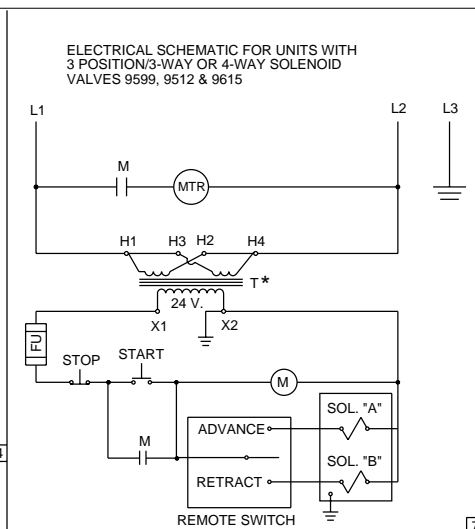
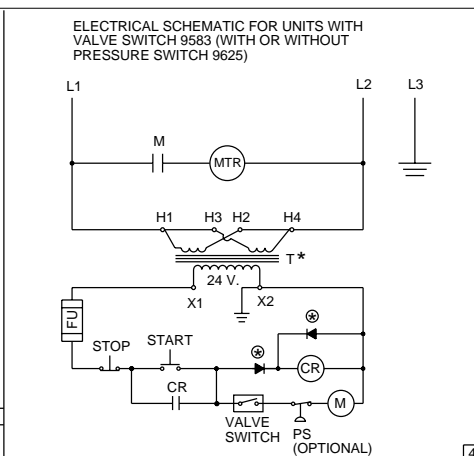
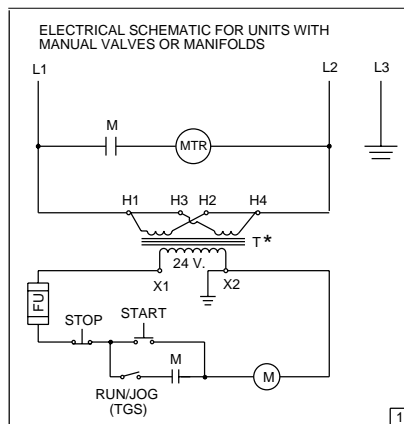

* NOTE: TRANSFORMER CONNECTIONS SHOWN ARE FOR 110/115 V., 50/60 HZ. FOR 220/230 V., 50/60 HZ. UNITS, TRANSFORMER CONNECTIONS TO BE AS FOLLOWS:
 H1 TO L1
 H2 & H3 TOGETHER
 H4 TO L2

⊗ NOTE: DIODES SHOWN IN SCHEMATICS ARE FOR 110/115 VOLT PRIMARY CIRCUITS ONLY, AND ARE NOT REQUIRED ON 220/230 VOLT CIRCUITS.



UNIVERSAL MOTOR

12,000 RPM, 115 & 230 Volt, 50/60 Hz.

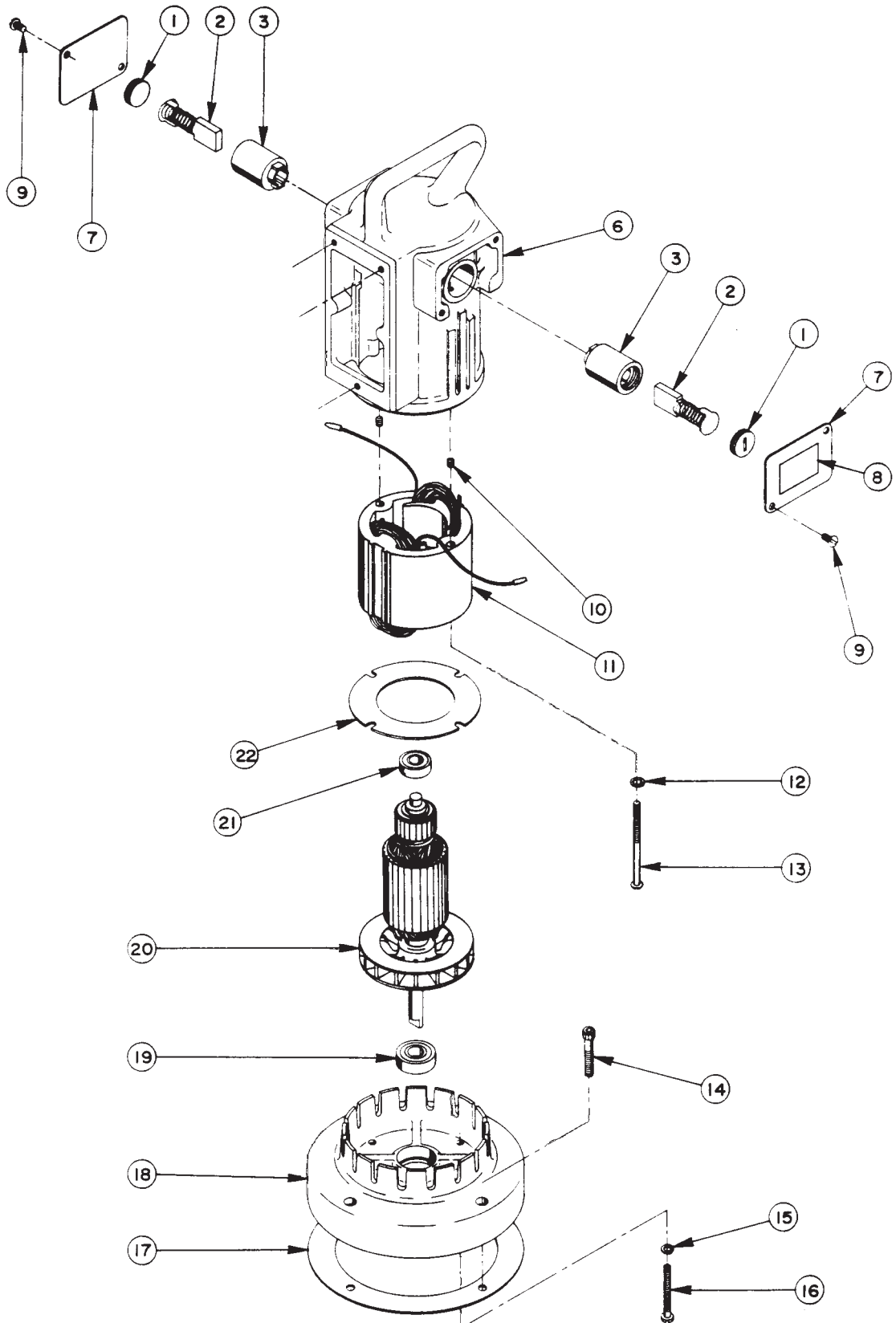

Item No.	Part No.	No. Req'd	Description
1	10806	2	Brush Holder Cap
2	10804	2	Brush Assembly
3	10805	2	Brush Holder (See note below)
6	61901	1	Motor Shell
7	21008	2	Cover
8	215164	1	Specifications Decal (For 115 Volt)
	215163	1	Specifications Decal (For 230 Volt)
9	10164	AR	Machine Screw (#10-24 x 3/8 Lg.)
10	10133	2	Set Screw
11	10802	1	Field (For 115 Volt)
	10803	1	Field (For 230 Volt)
12	12356	2	Lockwasher
13	10170	2	Machine Screw
14	10022	4	Cap Screw (#10-24 x 1-1/2 Lg.)
15	10241	4	Lockwasher
16	10169	4	Machine Screw (#10-24 x 2" Lg.; Torque to 20/25 in. lbs.)
17	30650	1	Gasket
18	40059	1	Motor Base
19	10439	1	Ball Bearing
20	10800	1	Armature (For 115 Volt; See note below)
	10801	1	Armature (For 230 Volt; See note below)
21	10438	1	Ball Bearing
22	20786	1	Baffle Plate



AR : As Required

BRUSH HOLDER & ARMATURE INSTALLATION SPECIFICATIONS

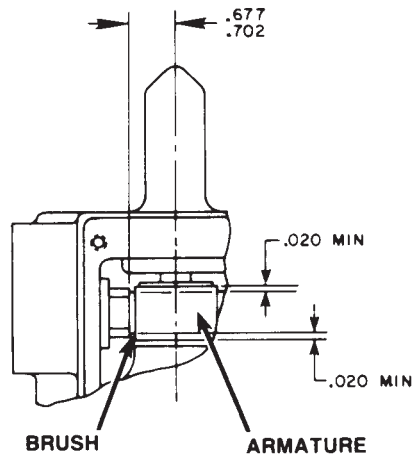

When replacing brushes or the armature, the dimensions shown must be as specified.

MOTOR CONTROL ASSEMBLY For PE55A & PE90A



THIS VIEW ROTATED 180°
TO SHOW WIRE CONNECTIONS.

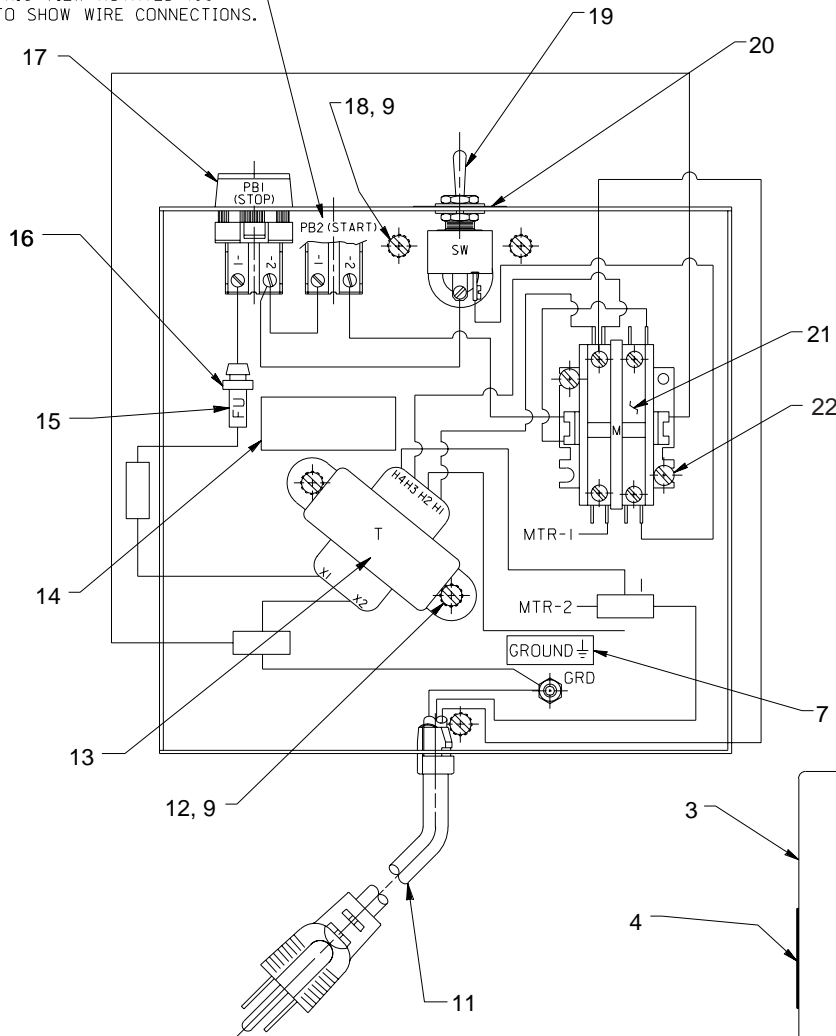

POWER CORD GROUND
(MUST BE ISOLATED BETWEEN
NUTS AND CAN BE AT
TOP OR BOTTOM OF STACK.)

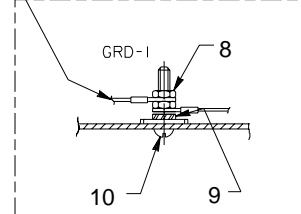

NOTE: SERRATED LOCK WASHER
MUST BE ADJACENT TO
METAL BOX. MORE WASHERS
CAN BE USED IF DESIRED.

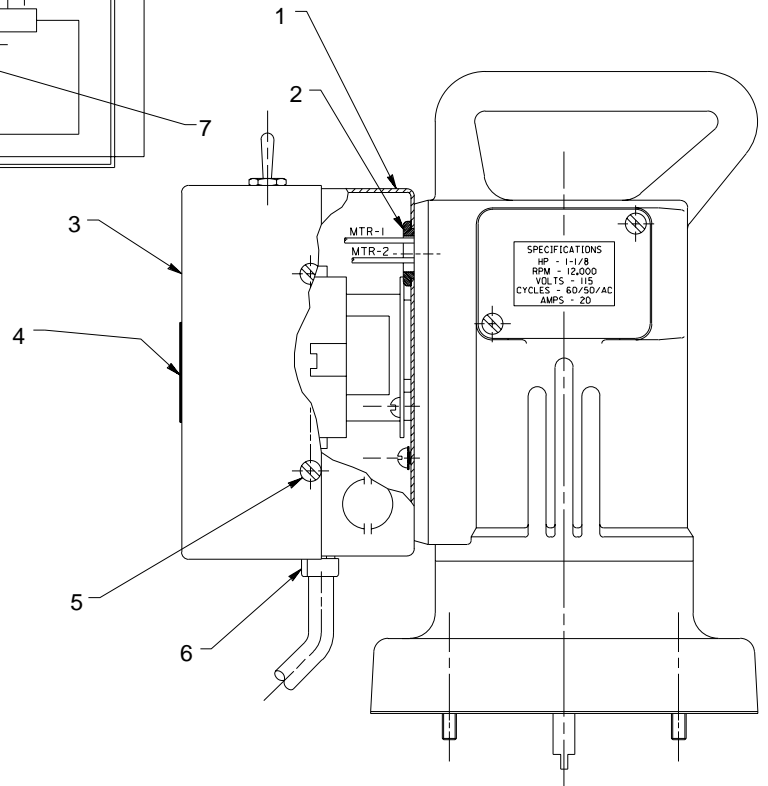

SPECIFICATIONS	
HP	- 1-1/8
RPM	- 12,000
VOLTS	- 115
CYCLES	- 60/50/AC
AMPS	- 20

(Note: For pumps built before Aug. 1, 1990 see parts list #100518)

Item No.	Part No.	No. Req'd	Description
1	51218WH2	1	Control Box
2	15497	1	Grommet
3	43126WH2	1	Control Box Cover
4	200188	1	Warning Decal
5	14812	4	Pan Hd. Screw (No. 8)
6	210112	1	Strain Relief Bushing
7	205189	1	Decal (Ground)
8	10197	2	Hex Nut (#10-24)
9	11108	3	Lockwasher (#10 External Tooth)
10	11856	1	Rd. Hd. Machine Screw (#10-24 x 1" Lg.)
11	307440	1	Cord Set (12/3 SJT0)
12	11539	6	Sl. Rd. Hd. Machine Screw (#10-24 UNC x 1/4 Lg.)
13	11852	1	Transformer
	350072	1	Transformer (For pumps equipped with solenoid valve)
14	250150	1	Decal (Fuse)
	250272	1	Decal (For pumps equipped with solenoid valve)
15	16887	1	Fuse Holder
16	206962	1	Fuse (3 amp)
	16888-8	1	Fuse (8 amp; For pumps equipped with solenoid valve)
17	309019	1	Double Pushbutton Switch
18	10164	3	Sl. Rd. Hd. Machine Screw (#10-24 UNC x 3/8 Lg.)
19	12301	1	Toggle Switch (On-Off)
20	204577	1	Decal (Run/Jog)
	250300	1	Decal (On/Off)
	250303	1	Decal (Run/Remote)
21	420718-4	1	Contactor
22	10166	2	Machine Screw (10-24 UNC x 1/2 Lg.)



OPTIONAL REMOTE MOTOR CONTROLS

25017	1	Remote Control Hand Switch (On/Off)
203225	1	Remote Control Hand Switch (Heavy duty rubber)
10461	1	Remote Control Foot Switch

OPTIONAL REMOTE SOLENOID VALVE CONTROLS

202777	1	Remote Control Hand Switch (Mom. On/Hold/Off; For 3-way Solenoid Valve)
202778	1	Remote Control Hand Switch (Mom. On/Off/Mom. On; For 4-way Solenoid Valve)
304718	1	Remote Control Hand Switch (Mom. On/Hold/Mom. Off)

ELECTRICAL SCHEMATIC
115 V./24 V., 50/60 Hz.

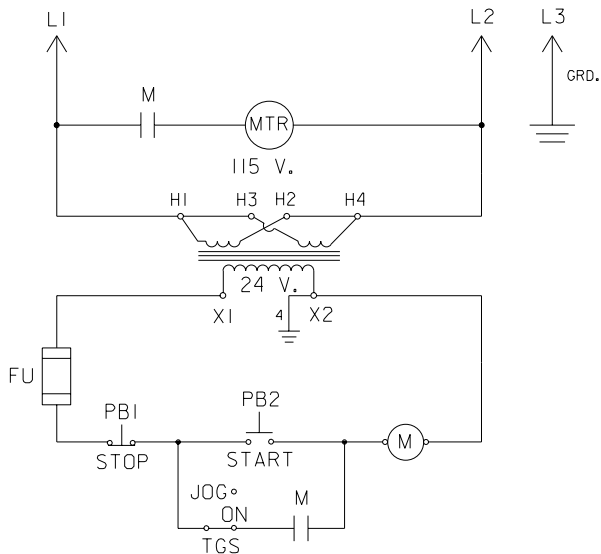

To help avoid personal injury, all electrical work must be done by a qualified electrician.

North American & International Color Codes

Conductors	North American	International
Line	Black	Brown
Neutral	White	Blue
Ground	Green	Green/Yellow

MOTOR CONTROL ASSEMBLY For PE55B & PE90B

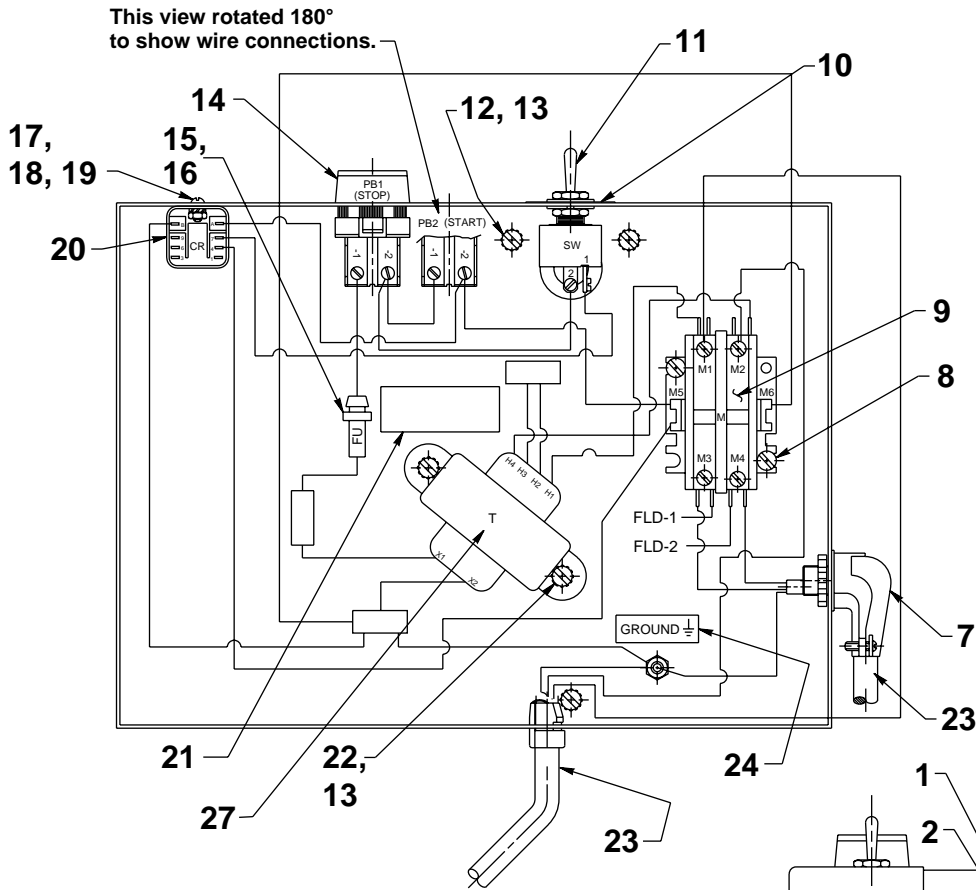

POWER CORD GROUND (MUST BE ISOLATED BETWEEN NUTS AND CAN BE AT TOP OR BOTTOM OF STACK.)

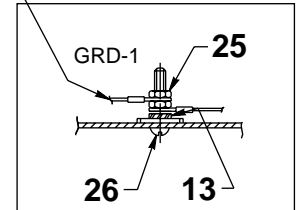

NOTE: SERRATED LOCK WASHER MUST BE ADJACENT TO METAL BOX. MORE WASHERS CAN BE USED IF DESIRED.

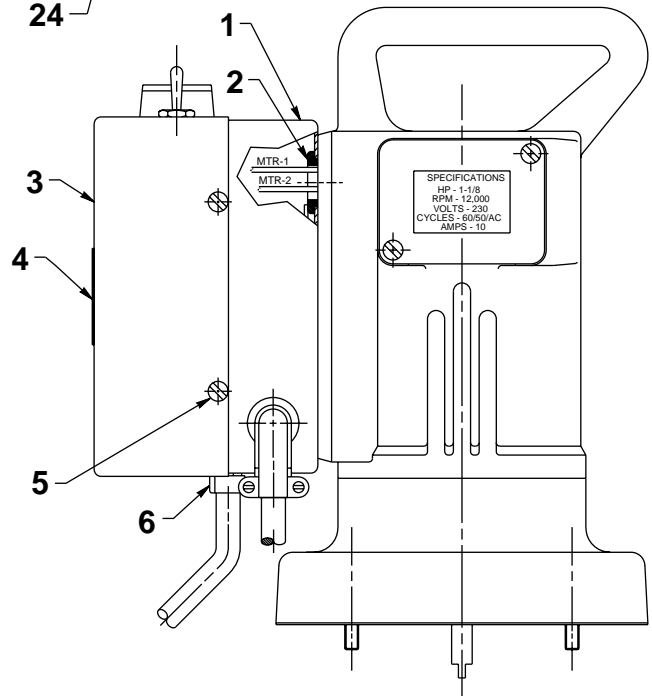

(Note: For pumps built before Aug. 1, 1990 see parts list #100518)

Item No.	Part No.	No. Req'd	Description
1	51218WH2	1	Control Box
2	15497	1	Grommet
3	43126WH2	1	Control Box Cover
4	200188	1	Warning Decal
5	14812	4	Pan Hd. Screw (No. 8)
6	210112	1	Strain Relief Bushing
8	10166	2	Machine Screw (10-24 UNC x 1/2 Lg.)
9	420718-4	1	Contactor
10	204577	1	Decal (Run/Jog)
	250300	1	Decal (On/Off)
	250303	1	Decal (Run/Remote)
11	12301	1	Toggle Switch (On-Off)
12	10164	3	Sl. Rd. Hd. Machine Screw (#10-24 UNC x 3/8 Lg.)
13	11108	6	Lockwasher (#10 External Tooth)
14	309019	1	Double Pushbutton Switch
15	206962	1	Fuse (3 amp)
	16888-8	1	Fuse (8 amp; For pumps equipped with solenoid valve)
16	16887	1	Fuse Holder
17	10159	2	Machine Screw (#6-32 UNC X 5/16 Lg.)
18	15906	2	Lockwasher (#6 External Tooth)
19	10195	2	Nut (#6-32 UNC)
20	39092	1	General Relay
21	250150	1	Decal (Fuse)
	250272	1	Decal (For pumps equipped with solenoid valve)

Item No.	Part No.	No. Req'd	Description
22	11539	6	Sl. Rd. Hd. Machine Screw (#10-24 UNC x 1/4 Lg.)
23	308752	8 ft.	Electrical Cable (14/3 SJT0)
24	205189	1	Decal (Ground)
25	10197	2	Hex Nut (#10-24)
26	11856	1	Rd. Hd. Machine Screw (#10-24 x 1" Lg.)
27	11852	1	Transformer
	350072	1	Transformer (For pumps equipped with solenoid valve)

OPTIONAL REMOTE MOTOR CONTROLS

25017	1	Remote Control Hand Switch (On/Off)
203225	1	Remote Control Hand Switch (Heavy duty rubber)
10461	1	Remote Control Foot Switch

OPTIONAL REMOTE SOLENOID VALVE CONTROLS

202777	1	Remote Control Hand Switch (Mom. On/Hold/Off; For 3-way Solenoid Valve)
202778	1	Remote Control Hand Switch (Mom. On/Off/Mom. On; For 4-way Solenoid Valve)
304718	1	Remote Control Hand Switch (Mom. On/Hold/Mom. Off)



ELECTRICAL SCHEMATIC
230 V./24 V., 50/60 Hz.

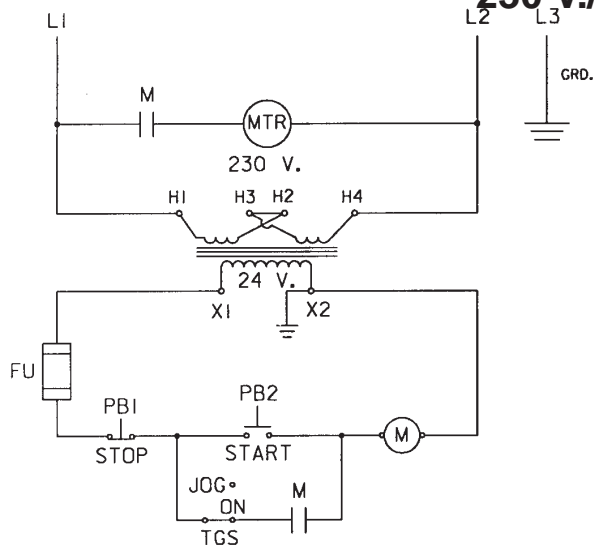

To help avoid personal injury, all electrical work must be done by a qualified electrician.

North American & International Color Codes

Conductors	North American	International
Line	Black	Brown
Neutral	White	Blue
Ground	Green	Green/Yellow

To Parts List

GENERAL PUMP ASSEMBLY

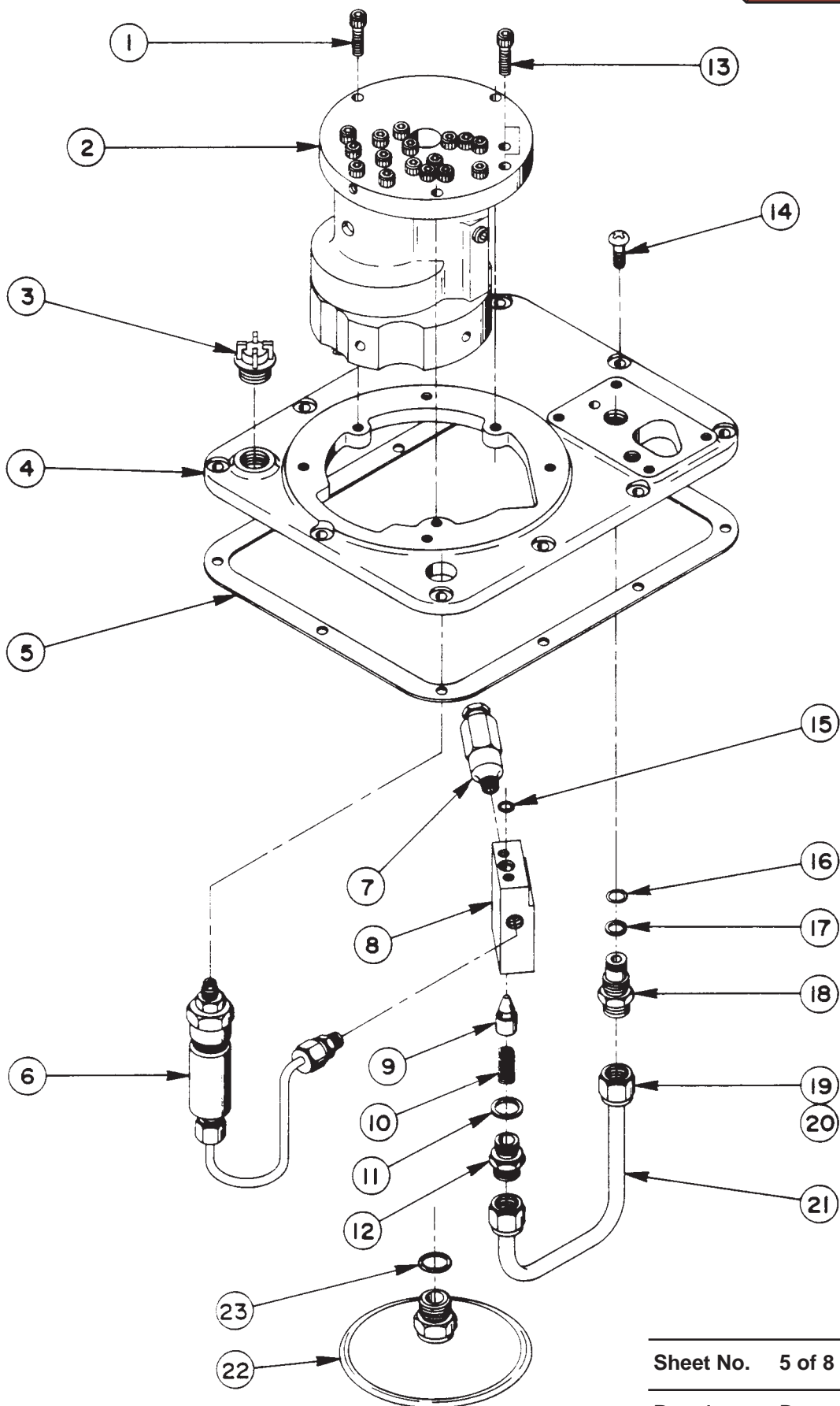

Parts List, Form No. 101223, Back sheet 5 of 8

Item No.	Part No.	No. Req'd	Description
1	10016	3	Soc. Hd. Cap Screw (1/4-20 UNC x 1" Lg.)
2	*27207	1	Basic Pump Ass'y Replacement (See chart below)
	*28348	1	Basic Pump Ass'y Replacement (See chart below)
3	20937	1	Filler Plug
4	40064WH2	1	Cover
5	40164	1	Gasket
6	22360	1	Pressure Regulator Assembly (See below)
7	21278	1	Relief Valve (Set at 10,100/10,700 PSI)
	21278-50	1	Relief Valve (Set at 5,100/5,700 PSI)
8	20776	1	Valve Body
9	20771	1	Poppet
10	10425	1	Compression Spring (3/8 O.D. x 3/4 Lg.)

Item No.	Part No.	No. Req'd	Description
11	10261	1	Copper Washer (3/4 x 19/32 x 1/32)
12	20770	1	Connector (Torque to 40/45 ft. lbs.)
13	10015	2	Soc. Hd. Cap Screw (1/4-28 UNF x 1" Lg.; Torque to 180 in. lbs.)
14	10177	10	Machine Screw (1/4-20 UNC x 3/4 Lg.)
15	10266	1	O-ring (3/8 x 1/4 x 1/16)
16	10268	1	O-ring (1/2 x 3/8 x 1/16)
17	11863	1	Teflon Backup Washer (1/2 x 3/8 x 1/16)
18	20787	1	Valve Connector
19	10430	2	Tube Sleeve
20	10431	2	Tube Nut
21	21045	1	Oil Line
22	21344	1	Filter Assembly (Includes Item 23)
23	10300	1	O-ring (5/8 x 15/32 x 5/64)



HIGH SPEED (12,000 RPM)

SERIES	MAX. PSI	BASIC PUMP ASS'Y	BASIC PUMP ASS'Y REPLACEMENT	HIGH PRES. PUMP ASS'Y	NO. OF PISTONS
PE55A & PE55B	10,000	50403	*27207	33113	3
PE90A & PE90B	5,000	50405	*28348	33114	6

*Includes all items on sheet 6 of 8 and items 1, 7, 8, 9, 10, 11, 12, 13, 15 & 22 on this sheet.

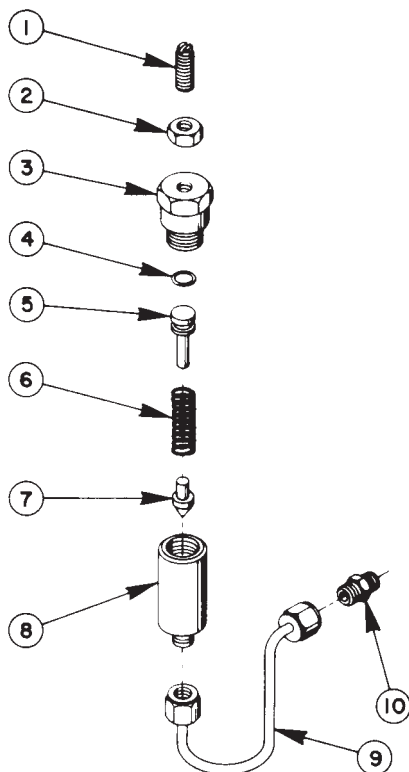

PRESSURE REGULATOR ASSEMBLY

Item No.	Part No.	No. Req'd	Description
1	22362	1	Adjusting Screw
2	10386	1	Hex Jam Nut (3/8-24 UNF)
3	21305	1	Valve Cap
4	10268	1	O-ring (1/2 x 3/8 x 1/16)
5	21306	1	Spring Guide
6	10495	1	Compression Spring (1/2 O.D. x 1-5/8 Lg.)
7	21046	1	Valve Stem
8	22361	1	Body
9	29267	1	Oil Line Assembly (with nuts)
10	14844	1	Connector Fitting

Note: Shaded areas reflect last revision(s) made to this form.



BASIC PUMP ASSEMBLY

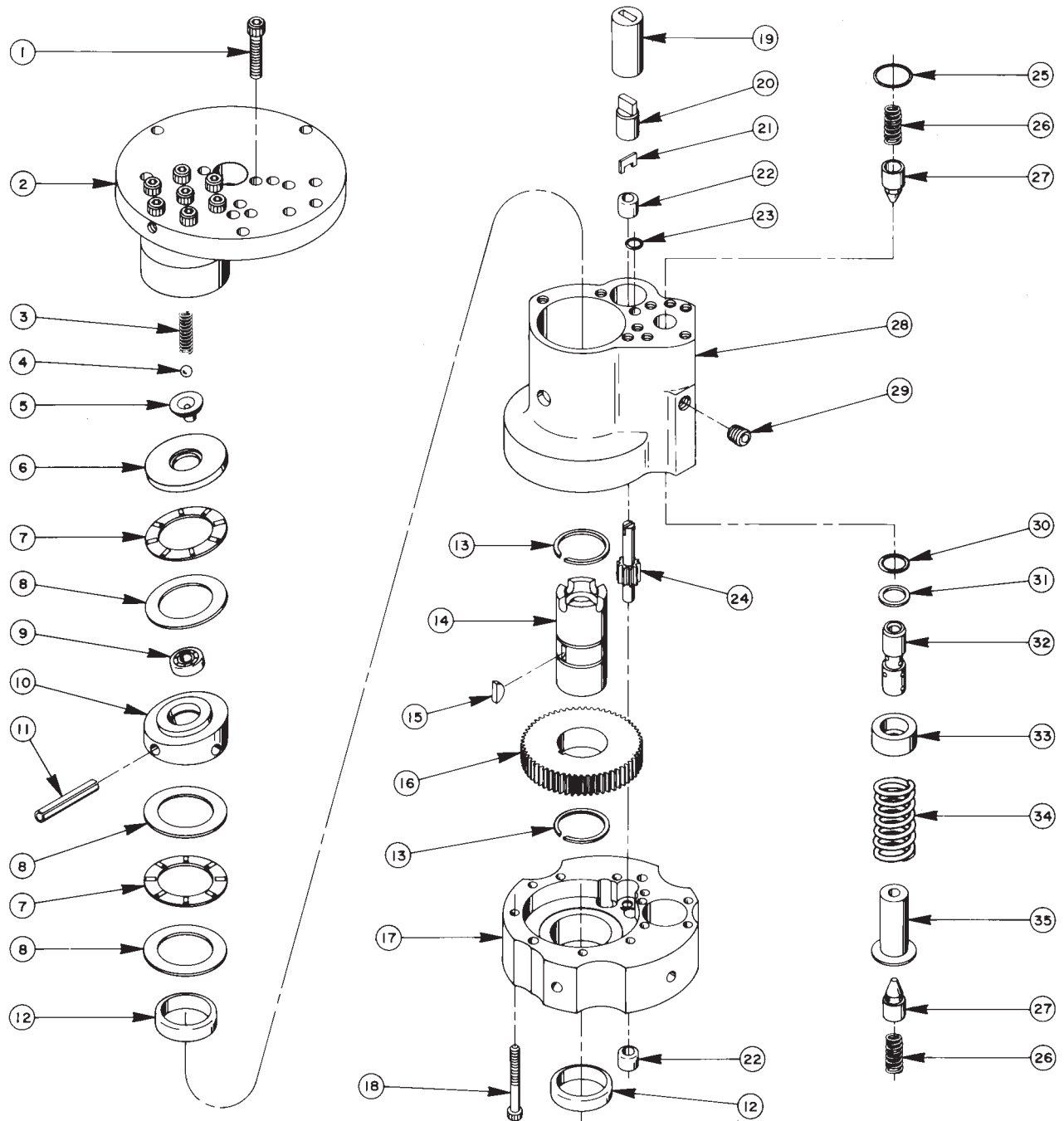

Parts List, Form No. 101223, Back sheet 6 of 8

Item No.	Part No.	No. Req'd	Description
1	10020	9	Soc. Hd. Cap Screw (1/4-20 UNC x 1-1/4 Lg.; Torque to 170/180 in. lbs.)
2	33113	1	High Pressure Pump Ass'y (See sheet 7 of 8 and chart on back sheet 5 of 8)
	33114	1	High Pressure Pump Ass'y (See sheet 7 of 8 and chart on back sheet 5 of 8)
3	10361	1	Compression Spring (1/4 O.D. x 1" Lg.)
4	10375	1	Steel Ball (1/4 dia.)
5	23547	1	Bearing Top Plate
6	23548	1	Top Plate
7	11228	2	Thrust Bearing
8	11813	3	Bearing Race
9	11814	1	Ball Bearing
10	23549	1	Angle Plate
11	11955	1	Roll Pin (1/4 dia. x 1-3/4 Lg.)
12	11064	2	Needle Bearing
13	11261	2	Retaining Ring
14	23556	1	Shaft
15	11821	1	Woodruff Key
16	23574	1	Gear
17	40072	1	Pump End Plate
18	10001	13	Soc. Hd. Cap Screw (#10-32 UNF x 1-3/4 Lg.; Torque to 50 in. lbs.)
19	21091	1	Zinc Coupling
20	21092	1	Adapter
21	21093	1	Key
22	11198	2	Needle Thrust Bearing (See note below)
23	10266	1	O-ring (3/8 x 1/4 x 1/16)
24	20774	1	Drive Gear
25	10303	1	O-ring (7/8 x 3/4 x 1/16)
26	10425	2	Compression Spring (3/8 O.D. x 3/4 Lg.)
27	20771	2	Poppet
28	40071	1	Pump Body
29	10427	1	Pipe Plug (1/8 NPTF)
30	10271	1	O-ring (11/16 x 1/2 x 3/32)
31	12389	1	Teflon Backup Washer (11/16 x 1/2 x 1/16)
32	20849	1	Spool
33	23255	1	Guide
34	10426	1	Compression Spring (1" O.D. x 1-13/16 Lg.)
35	23256	1	Spring Guide



NEEDLE BEARING INSTALLATION SPECIFICATIONS

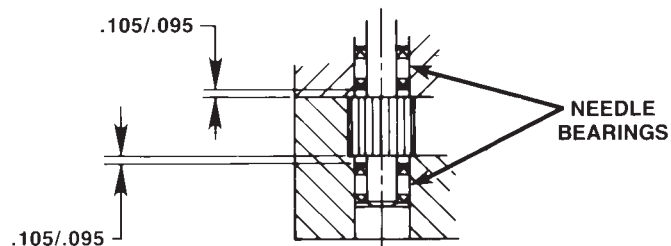

When replacing the needle bearings on the drive gear of the basic pump, the dimensions shown must be as specified.

Note: Shaded areas reflect last revision(s) made to this form.

HIGH PRESSURE PUMP ASSEMBLY

SEE DIAGRAM ON REVERSE SIDE FOR IMPORTANT ASS'Y INFORMATION.

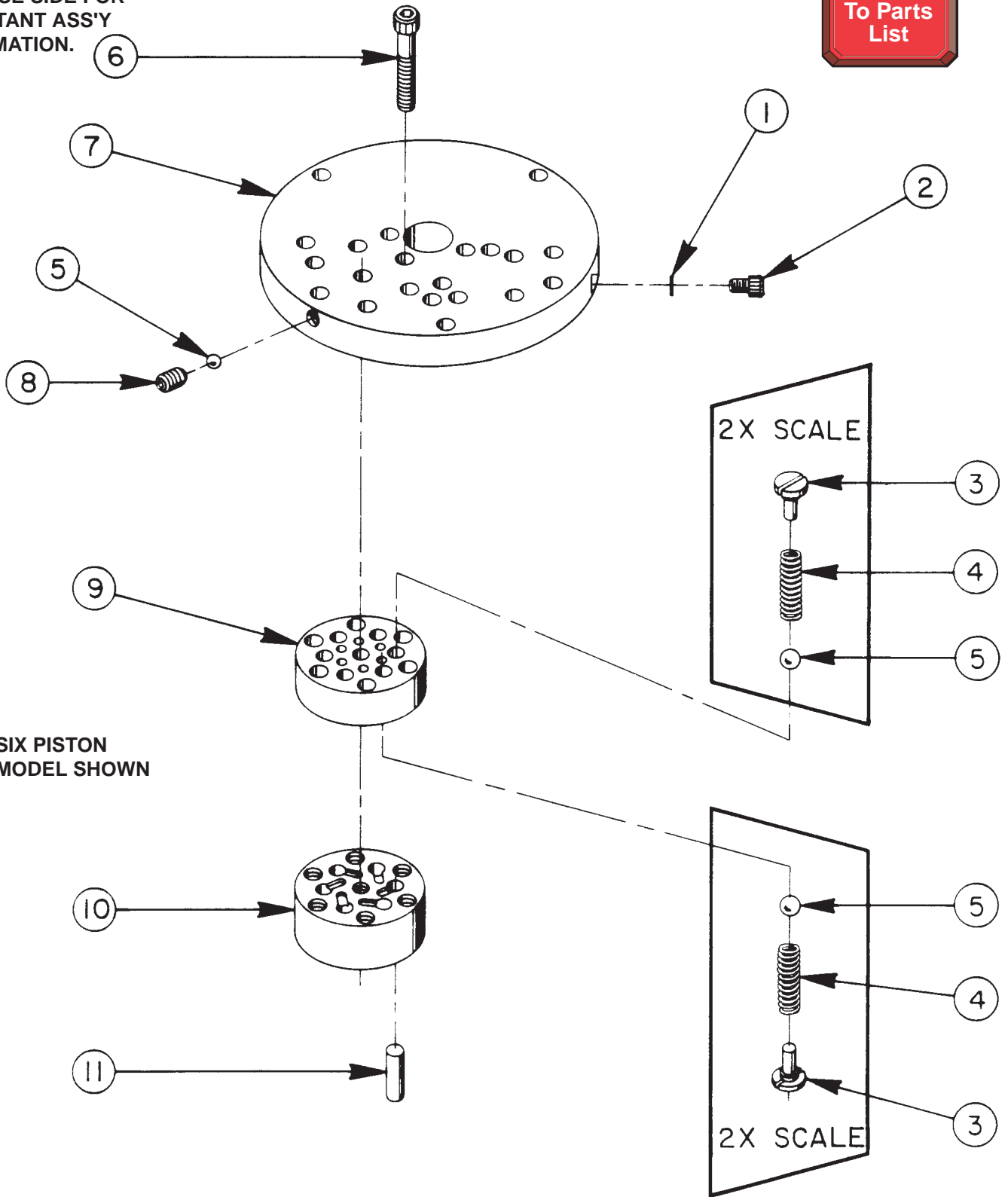

SIX PISTON MODEL SHOWN

33113 PUMP ASSEMBLY

3 Pistons, 9/32 Dia.

Item No.	Part No.	No. Req'd	Description
1	10442	1	Copper Washer (3/8 x 1/4 x 1/32)
2	10002	1	Soc. Hd. Cap Screw (1/4-20 UNC x 3/8 Lg.; Torque to 140/160 in. lbs.)
3	*24549	6	Valve Guide
4	*10445	6	Compression Spring (5/32 O.D. x 3/4 Lg.)
5	*12223	7	Steel Ball (3/16 dia.)
6	*10023	7	Soc. Hd. Cap Screw (1/4-28 UNF x 1-1/2 Lg.; Torque to 170/180 in. lbs.; See note below)
7	*50411	1	Top Plate
8	10519	1	Soc. Set Screw (1/4-20 UNC x 3/8 Lg.; Torque to 65/70 in. lbs.)
9	*40630	1	Valve Head
10	*41062	1	Pump Barrel
11	*21628	3	Piston

Consult factory when replacing items marked with an asterisk (*).

33114 PUMP ASSEMBLY

6 Pistons, 9/32 Dia.

Item No.	Part No.	No. Req'd	Description
1	10442	1	Copper Washer (3/8 x 1/4 x 1/32)
2	10002	1	Soc. Hd. Cap Screw (1/4-20 UNC x 3/8 Lg.; Torque to 140/160 in. lbs.)
3	*24549	12	Valve Guide
4	*10445	12	Compression Spring (5/32 O.D. x 3/4 Lg.)
5	*12223	13	Steel Ball (3/16 dia.)
6	*10023	7	Soc. Hd. Cap Screw (1/4-28 UNF x 1-1/2 Lg.; Torque to 170/180 in. lbs.; See note below)
7	*50411	1	Top Plate
8	10519	1	Soc. Set Screw (1/4-20 UNC x 3/8 Lg.; Torque to 65/70 in. lbs.)
9	*41048	1	Valve Head
10	*41063	1	Pump Barrel
11	*21628	6	Piston

Consult factory when replacing items marked with an asterisk (*).

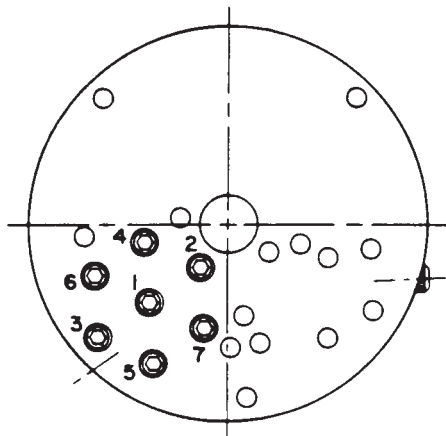

BOLT TIGHTENING SEQUENCE

NOTE: Assemble in sequence shown.
Lubricate under head and on threads.
Torque to 180 in. lbs.

RESERVOIR ASSEMBLIES



2 GAL. RESERVOIR

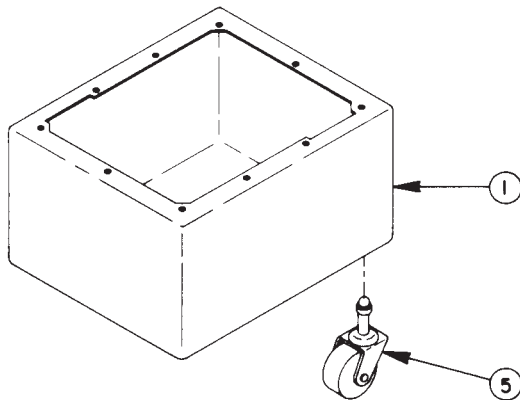

5 & 10 GAL. RESERVOIRS

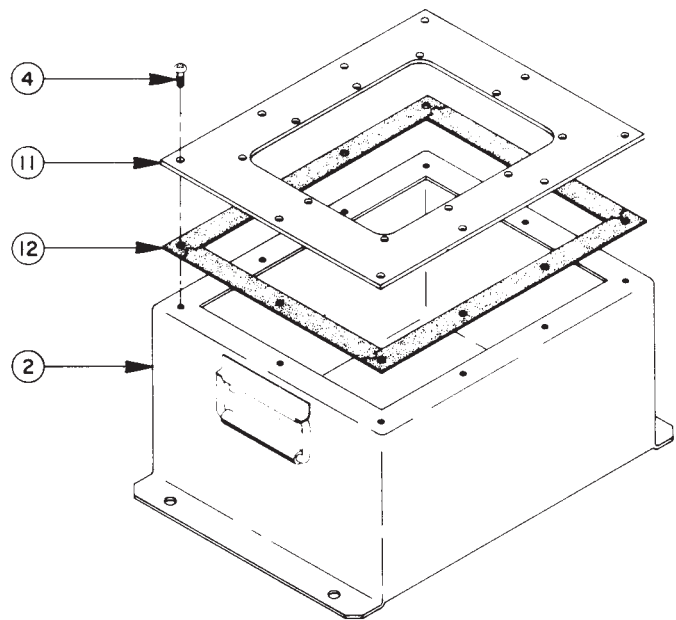

FILTER & EXTENSIONS

Used on 5, 7, & 10 Gal. Reservoirs as Applicable

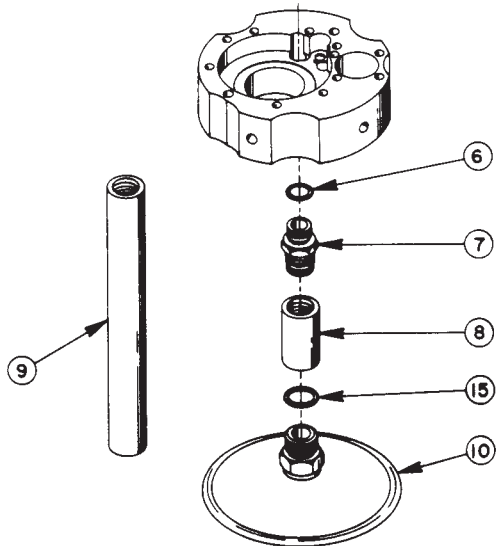

7 GAL. RESERVOIR

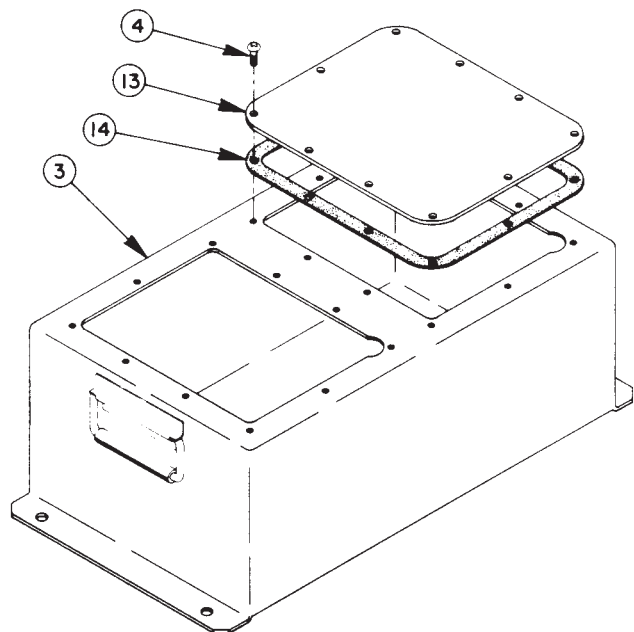

RESERVOIR ASSEMBLIES

NOTE: For complete Reservoir Assembly order the following:

- 209122 - 5 gallon reservoir assembly
- 209123 - 7 gallon reservoir assembly
- RP100 -10 gallon reservoir assembly

These numbers include the following parts listed below as applicable.

Item No.	Part No.	No. Req'd	Description
1	40063OR9	1	2 gallon Reservoir
	60597OR9	1	2 gallon Reservoir with handles and drain
2	40137OR9	1	5 gallon Reservoir
	40193OR9	1	10 gallon Reservoir
3	50051OR9	1	7 gallon Reservoir
4	10177	10	Machine Screw (1/4-20 UNC x 3/4 Lg.)
5	10494	4	Swivel Caster (For 2 gallon reservoir)
6	10300	1	O-ring (5/8 x 15/32 x 5/64)
7	20879	1	Connector
8	22032	1	Suction Line (For 5 & 7 gallon reservoir)
9	22038	1	Suction Line (For 10 gallon reservoir)
10	21345	1	Filter Assembly
11	40194AL2	1	Adapter Cover Plate (For 5 & 10 gallon reservoir)
12	40490	1	Gasket (For 5 & 10 gallon reservoir)
13	40188AL2	1	Cover Plate (For 7 gallon reservoir)
14	40164	1	Gasket (For 7 gallon reservoir)
15	10527	1	O-ring (13/16 x .644 x .087)

PARTS NOT SHOWN

309219	2	Trade Name Decal
--------	---	------------------



Refer to any operating instructions included with this product for detailed information about operation, testing, disassembly, reassembly, and preventive maintenance.

Items found in this parts list have been carefully tested and selected. **Therefore: Use only genuine Power Team replacement parts!**

Additional questions can be directed to our Technical Services Department.