

Parts List for:

4008
4009
P460

P460 Series
P460D
P460D Series

MODEL C
TWO-STAGE HYDRAULIC HAND PUMP
GENERAL ASSEMBLY

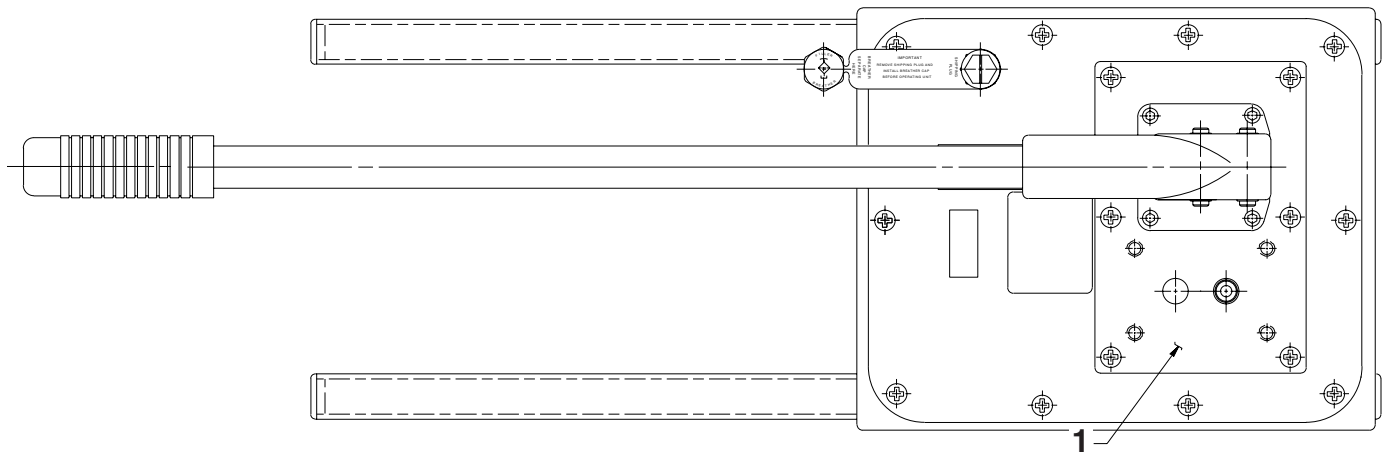

Basic Pump Assembly - See back sheet 1 of 3

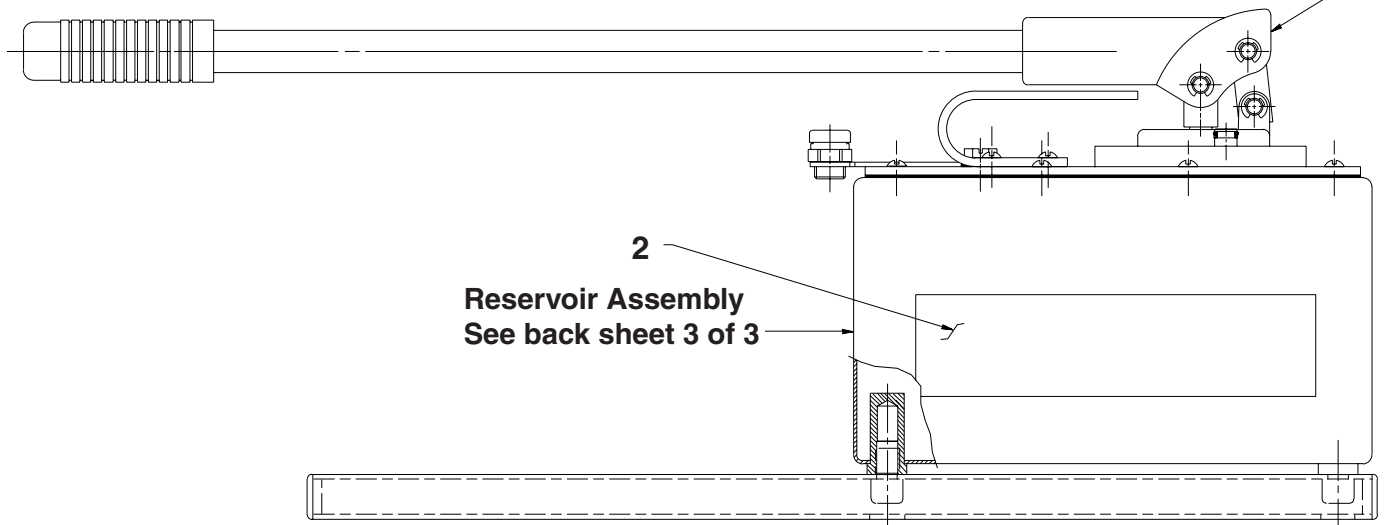

Reservoir Assembly
See back sheet 3 of 3

Item No.	Part No.	No. Req'd	Description
1	420295	1	Valve (3-way; For P460 & 4008)
	52510	1	Valve (4-way; For P460D & 4009. Note: Use drain tube #202781)
2	250959	2	Trade Name Decal (For 4008 & 4009)
	309219	2	Trade Name Decal (For P460 & P460D)

BASIC PUMP ASSEMBLY

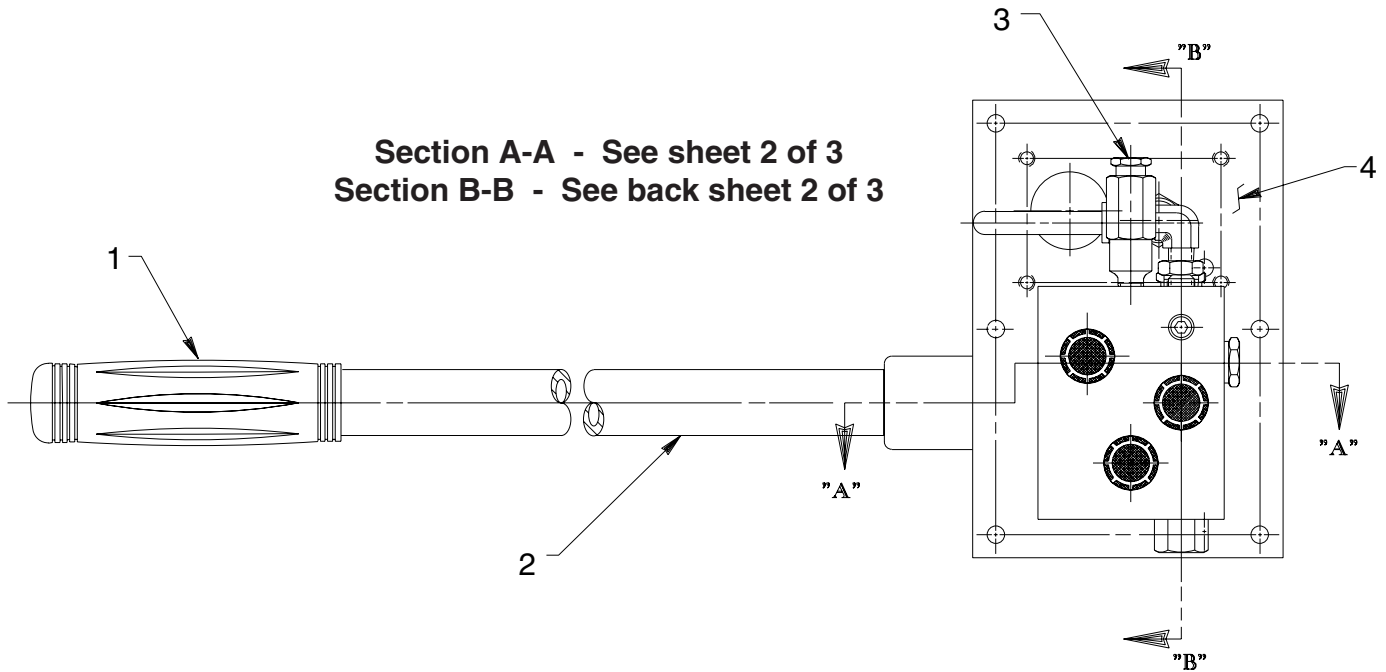

Item No.	Part No.	No. Req'd	Description
1	11390	1	Flex Grip Handle
2	30708	1	Handle
3	21278	1	Relief Valve Assembly (See note below)
4	420418GY8	1	Cover Plate

NOTE

Standard relief valves are set at 10,100/10,700 PSI.
Relief valves pre-set at special settings are available.
Refer to your pump model number or contact Power Team Technical Services.

SECTION A-A

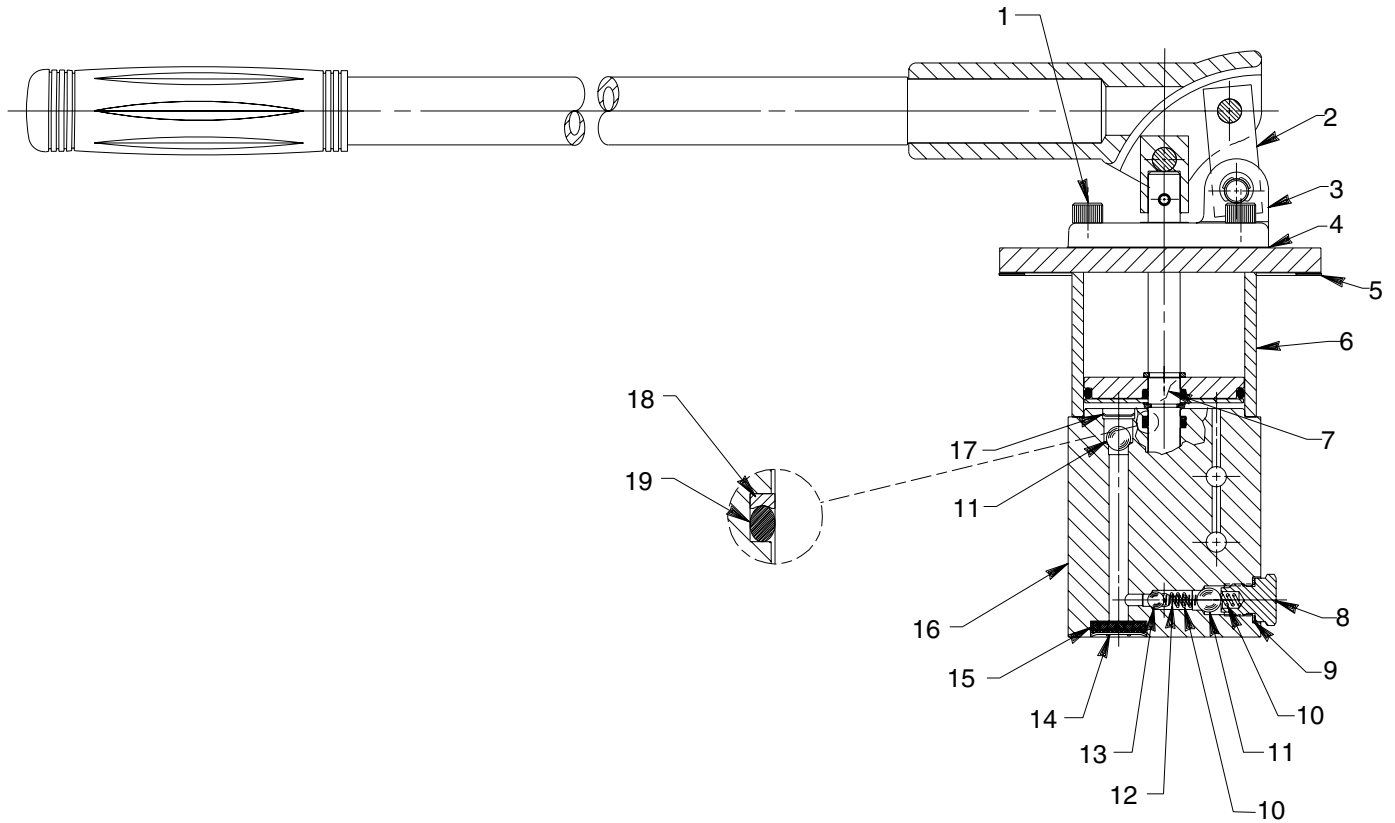

Item No.	Part No.	No. Req'd	Description	Item No.	Part No.	No. Req'd	Description
1	250671	4	Screw (5/16-24 UNF x 3-1/2 Lg.; Torque to 240/250 in. lbs.) Note: Torque in increments of 100 in. lbs.	10	10444	2	Compression Spring (3/16 I.D. X 13/32 Lg.)
2	21603	1	Pivot Block	11	10378	2	Steel Ball (3/8 dia.)
3	420419BK2	1	End Cap	12	211797	1	Spring (5/32 O.D. X 5/8 Lg.)
4	*22143	1	End Cap Gasket	13	10375	1	Steel Ball (1/4 dia.)
5	*30709	1	Reservoir Gasket	14	*214586	3	Retaining Ring (Internal)
6	350302	1	Spacer	15	*214578	3	Filter (Insert screen with cupped side in.)
7	251342	1	Piston Assembly (Nitrile seals)	16	64202	1	Pump Body
	251518	1	Piston Assembly (Viton seals)	17	*250670	2	Retaining Ring
	251519	1	Piston Assembly (EPR seals)	18	*213987	1	Backup Washer (Assemble with concave surface towards o-ring.)
8	305975	1	Valve Screw (Torque to 350/370 in. lbs.)	19	*10271	1	O-ring (11/16 X 1/2 X 3/32; Nitrile)
9	*14874	1	Soft Copper Washer (.700 X 1/2 X 1/32)		†11445	1	O-ring (11/16 X 1/2 X 3/32; Viton)
					•19406	1	O-ring (11/16 X 1/2 X 3/32; EPR)

Part numbers marked with an asterisk (*) are contained in Repair Kit No. 300617.
 Part numbers marked with a dagger (†) are contained in Viton Seal Kit No. 300662.
 Part numbers marked with a bullet (•) are contained in EPR Seal Kit No. 300663.

Note: For a piston replacement repair kit, order #300999.

Note: Shaded areas reflect last revision(s) made to this form.

SECTION B-B

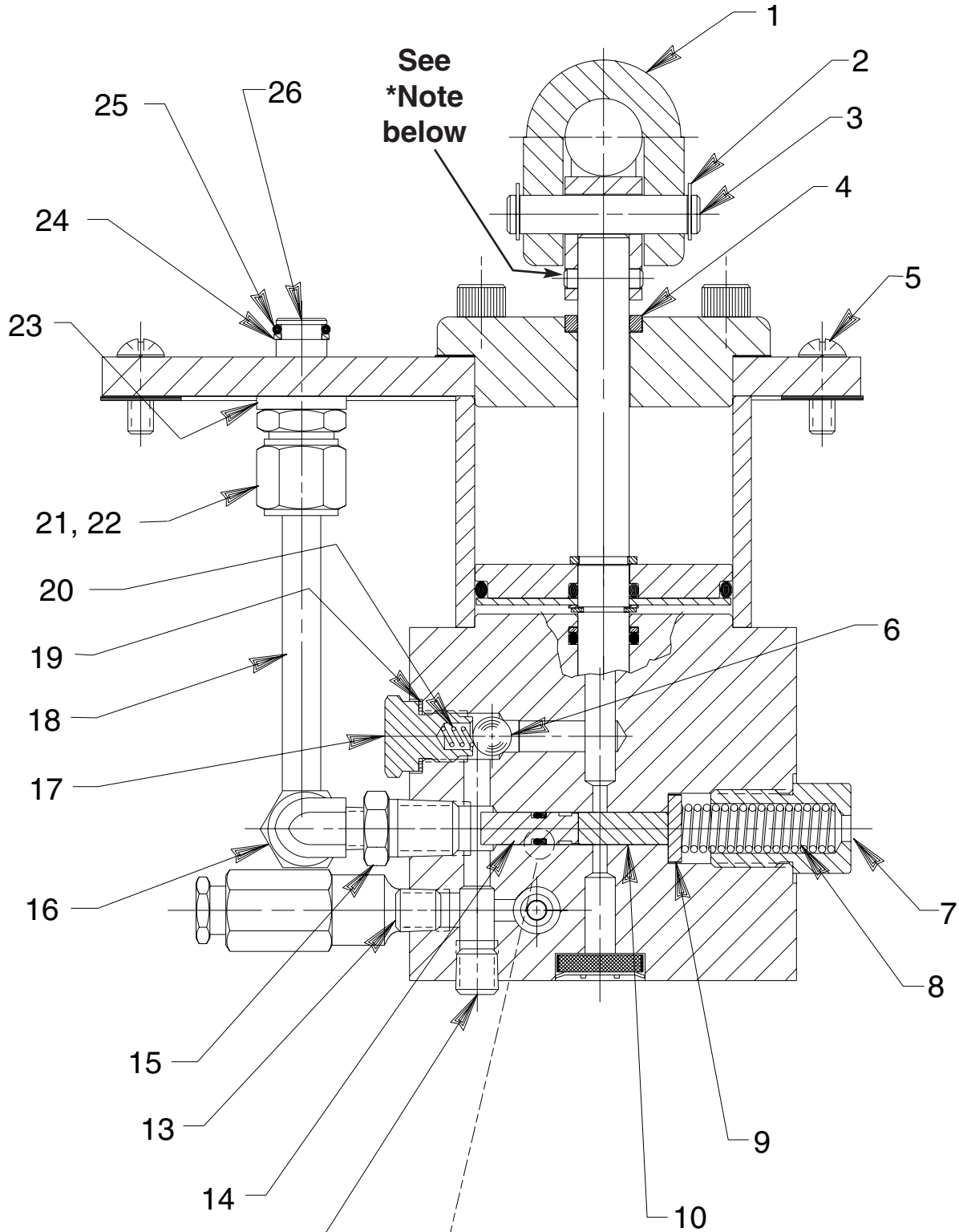

See
*Note
below

***Note:** Attachment of the handle assembly to the piston assembly was done differently on Model C pumps built before and after May 1993. Use the following directions to remove the handle based on when your pump was built:
For pumps built before May 1993: Heat the handle connector to 600° F to break the Loctite seal.
For pumps built after May 1993: Remove roll pin from the piston/ring assembly and handle connector.

Item No.	Part No.	No. Req'd	Description
1	30701	1	Lever
2	11032	6	Retaining Ring
3	21609	3	Clevis Pin
4	*15092	1	Rod Wiper (Nitrile)
	†19321	1	Rod Wiper (Viton)
	•250841	1	Rod Wiper (EPR)
5	10177	6	Machine Screw (1/4-20 UNC X 3/4 Lg.)
6	10378	1	Steel Ball (3/8 dia.)
7	308430	1	Unloading Valve Fitting
8	10367	1	Compression Spring (1/2 O.D. x 2" Lg.)
9	214692	1	Disc
10	250672	1	Dowel Pin
11	*15174	1	Backup Ring (5/16 X 3/16 X 3/64)
12	*10265	1	O-ring (5/16 X 3/16 X 1/16; Nitrile)
	†11437	1	O-ring (5/16 X 3/16 X 1/16; Viton)
	•17714	1	O-ring (5/16 X 3/16 X 1/16; EPR)
13	10427	2	Pressure Plug
14	250658	1	Unloading Valve Piston
15	13269	1	Reducer Bushing
16	10475	1	Tube Elbow
17	305975	1	Valve Screw (Torque to 350/370 in. lbs.)
18	350340	1	Oil Line
19	14874	1	Soft Copper Washer (.700 X 1/2 X 1/32)
20	10444	1	Compression Spring (3/16 I.D. X 13/32 Lg.)
21	10430	1	Tube Sleeve (3/8)
22	10431	1	Tube Nut (Torque to 40/50 ft. lbs.)
23	21484	1	Spacer
24	*11863	1	Backup Washer (1/2 X 3/8 X 1/16)
25	*10268	1	O-ring (1/2 X 3/8 X 1/16; Nitrile)
	†19775	1	O-ring (1/2 X 3/8 X 1/16; Viton)
	•17716	1	O-ring (1/2 X 3/8 X 1/16; EPR)
26	20787	1	Valve Connector (Torque to 20/30 ft. lbs.)

Part numbers marked with an asterisk (*) are contained in Repair Kit No. 300617.
Part numbers marked with a dagger (†) are contained in Viton Seal Kit No. 300662.
Part numbers marked with a bullet (•) are contained in EPR Seal Kit No. 300663.

TWO GALLON RESERVOIR ASSEMBLY

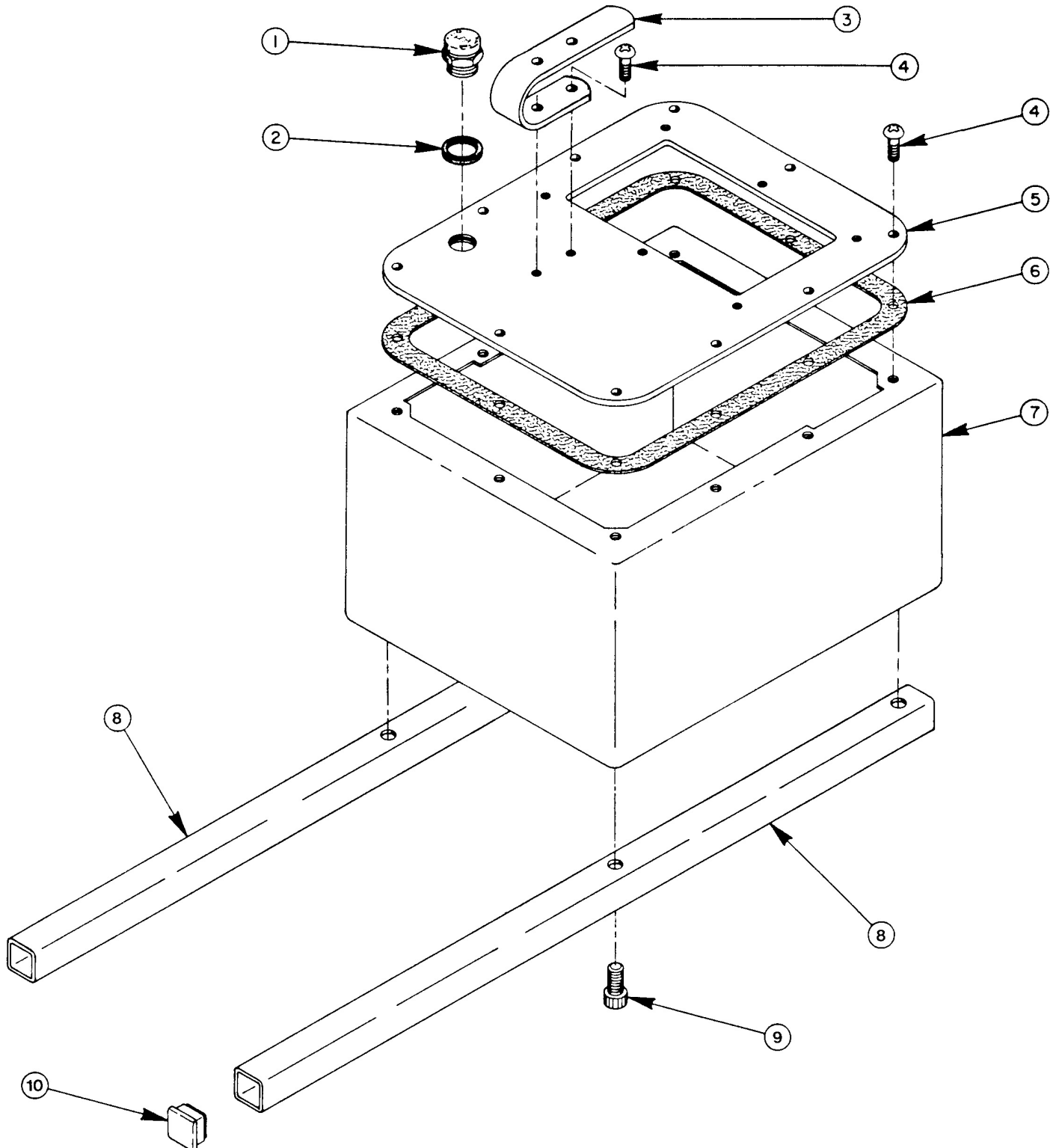

Item No.	Part No.	No. Req'd	Description
1	20937	1	Filler/Vent Cap
2	*200415	1	Rubber Seal
3	24066	1	Handle
4	10177	12	Machine Screw (1/4-20 UNC x 3/4 Lg.)
5	41810WH2	1	Cover Plate

Item No.	Part No.	No. Req'd	Description
6	47409	1	Cover Gasket
7	40063BL2	1	Reservoir (For 4008 & 4009)
	40063OR9	1	Reservoir (For P460 & P460D)
8	307569	2	Support Tube
9	213836	4	Soc. Hd. Cap Screw
10	12126	4	Plastic Tube Insert

Part numbers marked with an asterisk (*) are contained in Repair Kit No. 300617.