

Parts List for:

P126-10
P126-10-50-220

**MODEL B
ELECTRIC
TWO-STAGE HYDRAULIC PUMP**

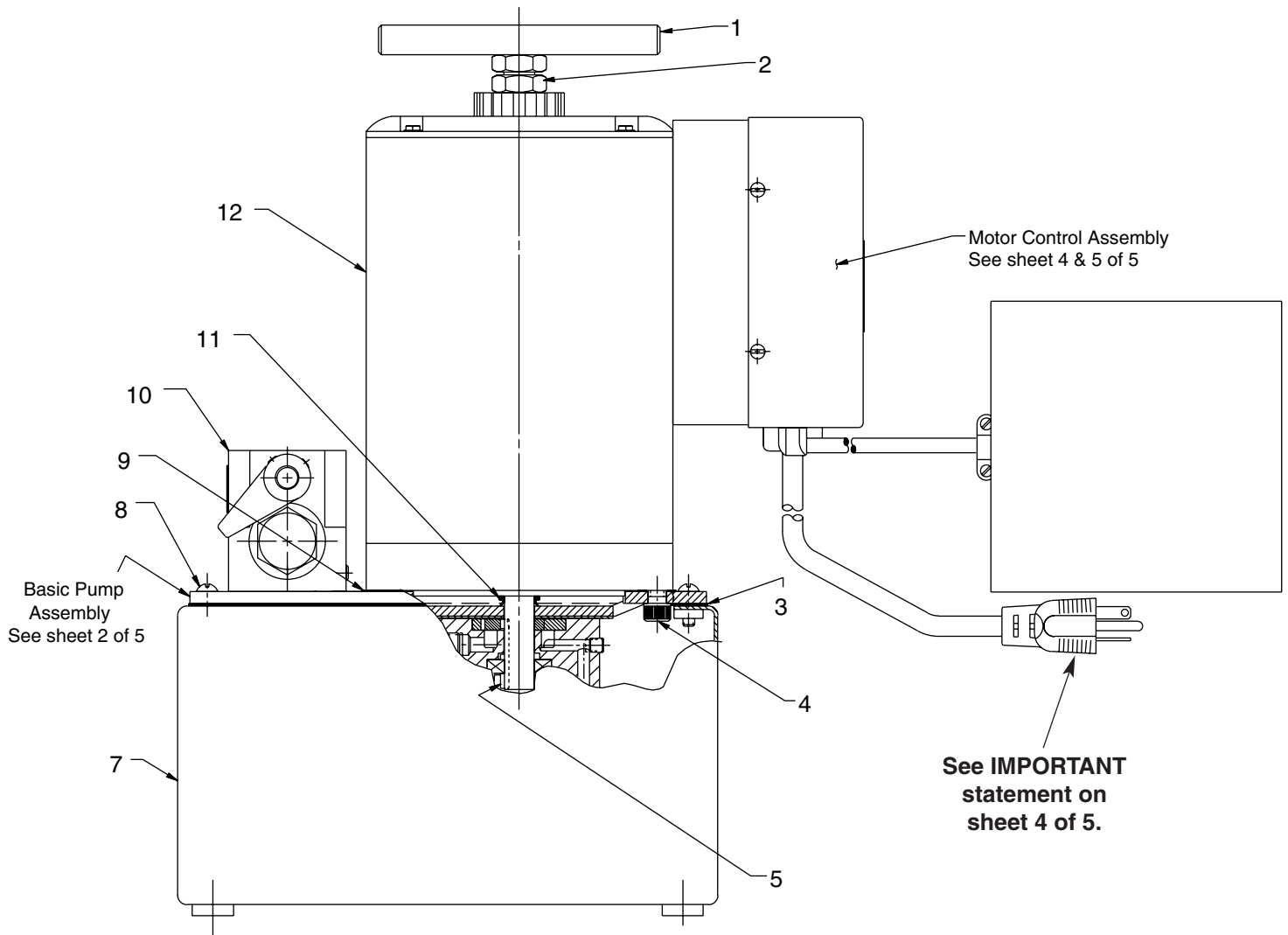

Item No.	Part No.	No. Req'd	Description
1	203146	1	T-handle
2	10394	1	Hex Nut
3	40164	1	Gasket
4	10050	4	Cap Screw (3/8-16 X 1" Lg.; Torque to 90/100 in. lbs.)
5	214097	1	Key
7	40063BL20	1	Reservoir
8	10177	10	Machine Screw (1/4-20 UNC X 3/4 Lg.)
9	307425	1	Motor Base Gasket
10	420669	1	Automatic/Manual Valve
11	213674	1	V-ring
12	58053BL20	1	Electric Motor (For P126-10)
	53104WH2	1	Electric Motor (For P126-10-50-220)

HYDRAULIC SCHEMATIC

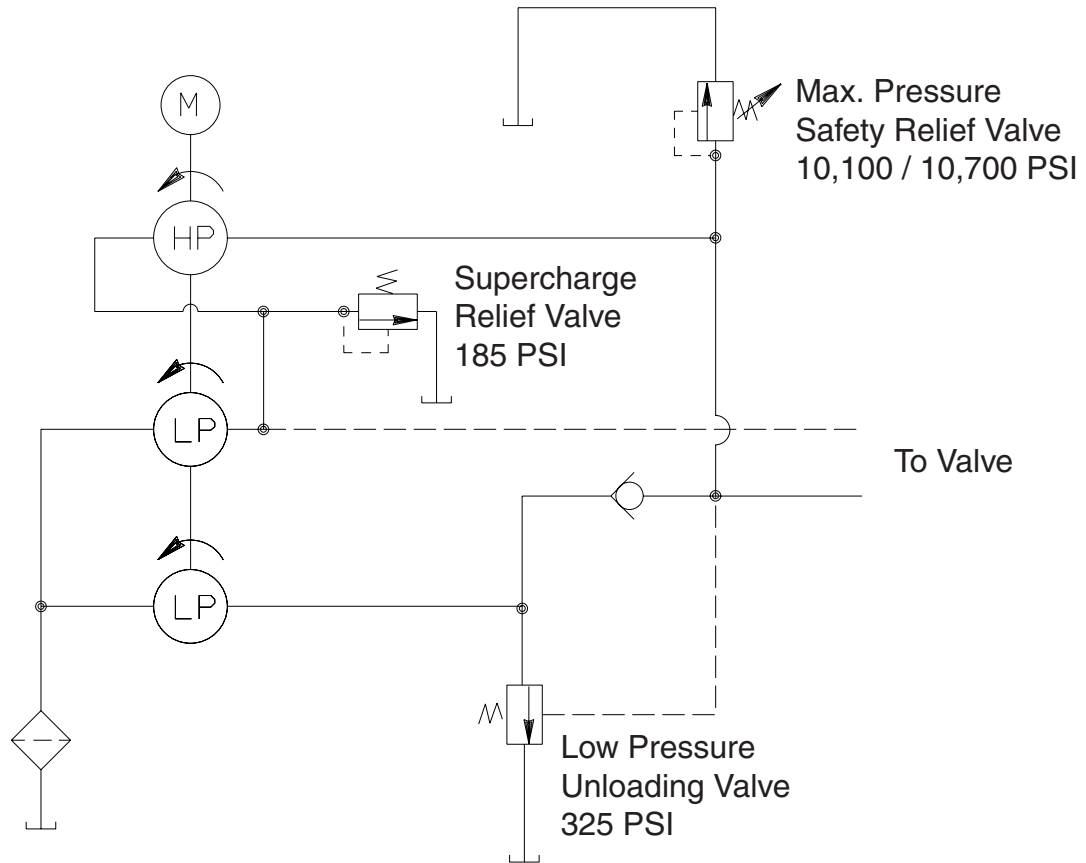

Refer to any operating instructions included with this product for detailed information about operation, testing, disassembly, reassembly, and preventive maintenance.

Items found in this parts list have been carefully tested and selected. **Therefore: Use only genuine Power Team replacement parts!**

Additional questions can be directed to our Technical Services Department.

Note: Removed decal (Item #6) at last revision(s) made to this form.

BASIC PUMP ASSEMBLY SIDE VIEW

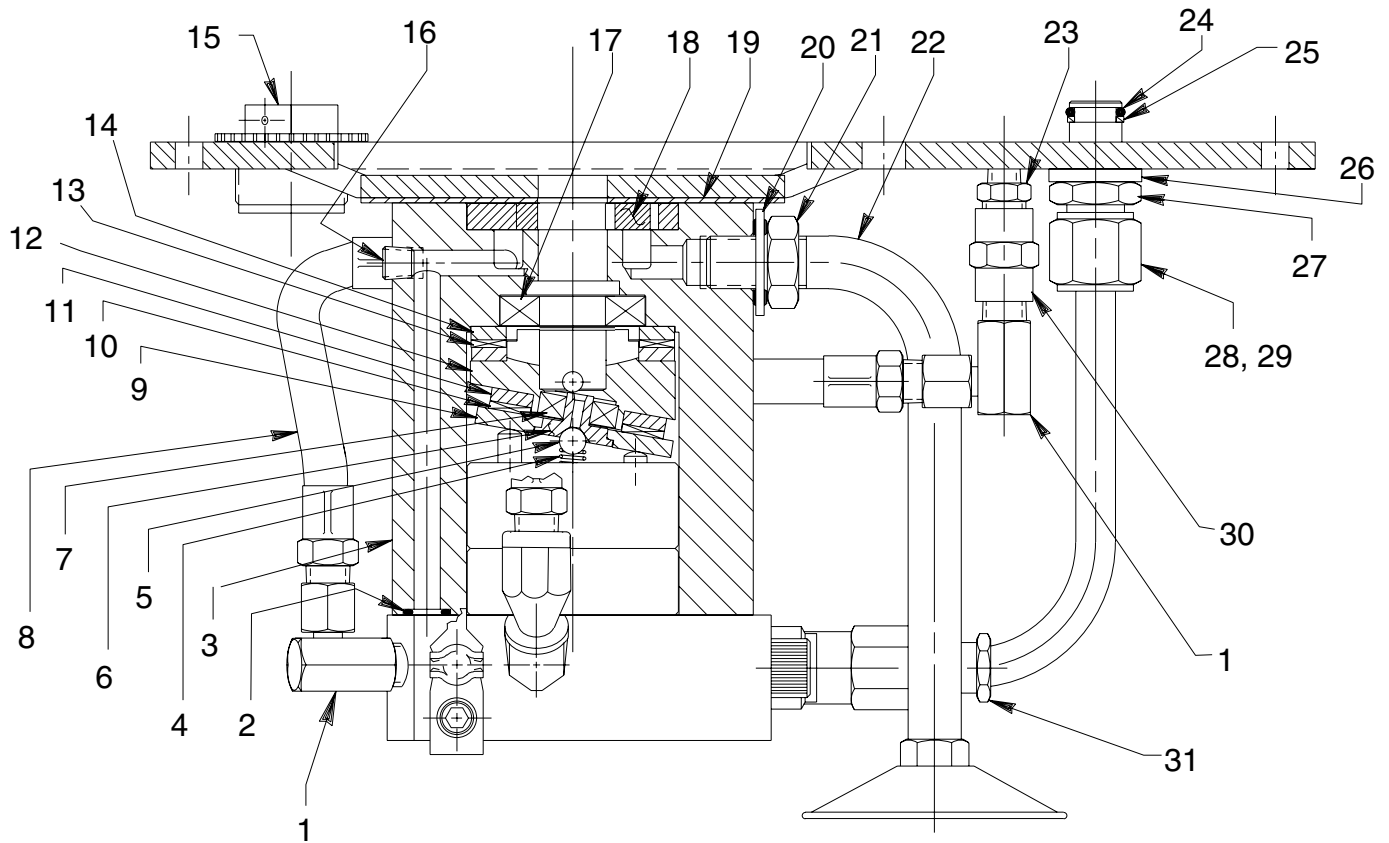

Item No.	Part No.	No. Req'd	Description
1	14440	2	Straight Fitting
2	10267	1	O-ring (7/16 x 5/16 x 1/16)
3	58333	1	Pump Body
4	16320	1	Compression Spring (1/4 O.D. x 3/4 Lg.)
5	10375	1	Steel Ball (1/4 dia.)
6	23547	1	Top Plate Bearing
7	11814	1	Ball Bearing
8	304819	1	Hose Assembly
9	23548	1	Top Plate
10	15431	1	Needle Thrust Bearing
11	15432	1	Needle Thrust Bearing Race
12	350487	1	Angle Plate
13	11228	1	Needle Thrust Bearing
14	11227	2	Needle Thrust Bearing Race
15	213706	1	Filler Cap
16	11084	1	Pipe Plug (1/16 NPTF; Torque to 35/45 in. lbs. oiled)
17	15695	1	Ball Bearing
18	15693	1	Gerotor Set
19	307296	1	Wear Plate (NOTE: Install with metal stamped side of plate toward motor. Disregard stamped note.)

Item No.	Part No.	No. Req'd	Description
20	213709	1	Washer Seal (Turn on, do not push on)
21	10390	1	Nut (1/2-20 UNF)
22	213686	1	Intake Tube
23	215373	1	Straight Fitting
24	10268	1	O-ring (1/2 x 3/8 x 1/16)
25	11863	1	Backup Washer (1/2 x 3/8 x 1/16)
26	21484	1	Washer
27	214882	1	Valve Connector (Note: Torque valve connector to 20/30 ft. lbs. into cover plate. Hold valve connector and torque tube nut [item 29] to 40/50 ft. lbs.)
28	10430	1	Tube Sleeve
29	10431	1	Tube Nut
30	18841	1	Pipe Connector
31	21278	1	Relief Valve (Set at 10,100 / 10,700 PSI)

BASIC PUMP ASSEMBLY-BOTTOM VIEW

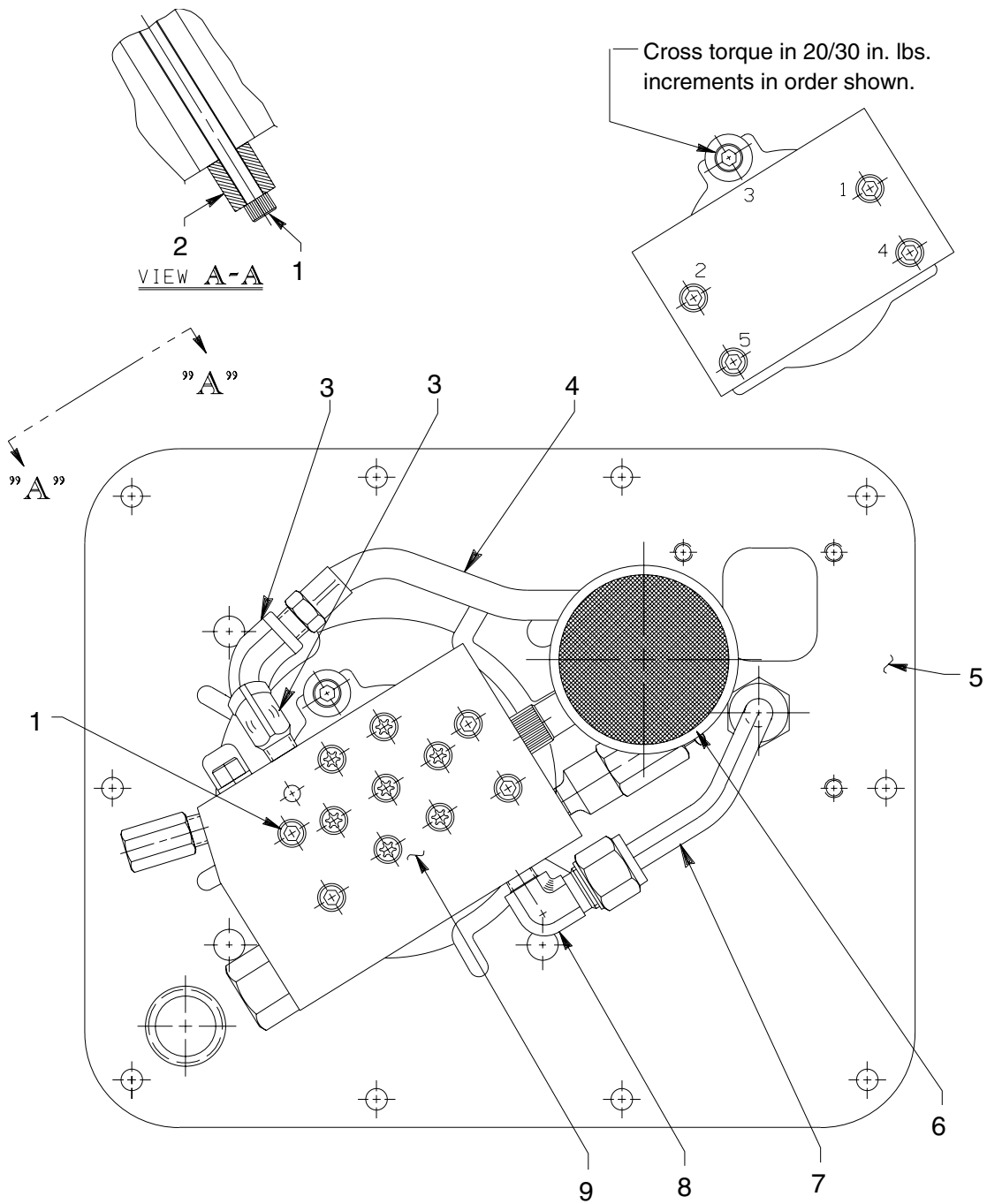

Item No.	Part No.	No. Req'd	Description
1	15642	5	Cap Screw (1/4-20 UNC X 5" Lg.; Torque to 55/65 in. lbs.)
2	214720	1	Spacer
3	19121	2	45° Elbow Fitting
4	304819	1	Hose Assembly
5	47606	1	Cover Plate
6	29682	1	Filter
7	350596	1	Oil Tube
8	10475	1	Tube Elbow
9	420556	1	High Pressure Pump (See sheet 3 of 5)

HIGH PRESSURE PUMP ASSEMBLY

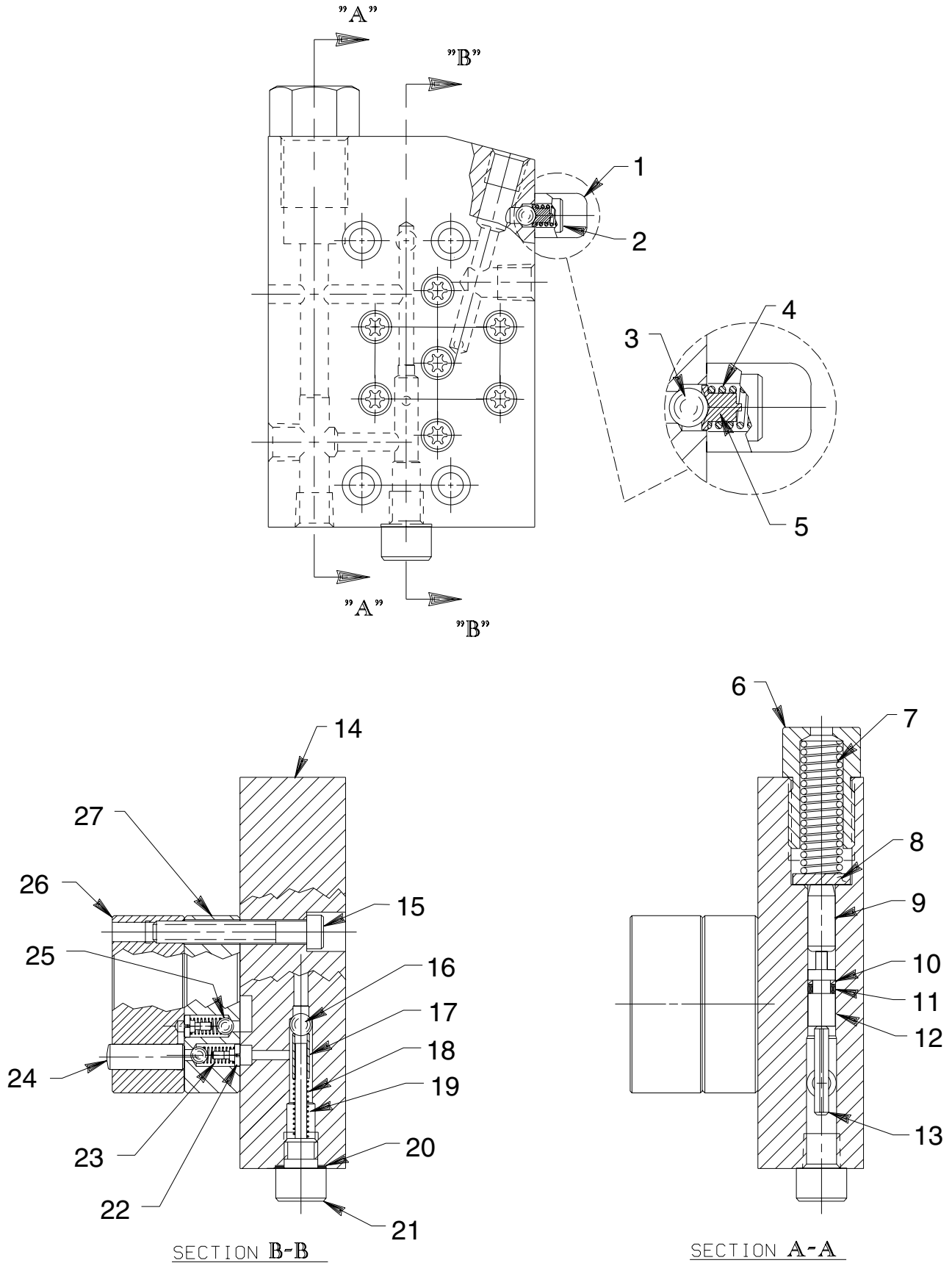

Item No.	Part No.	No. Req'd	Description
1	350577	1	Spring Retainer
2	10002	1	Cap Screw (1/4-20 UNC X 3/8 Lg.)
3	10374	1	Steel Ball (7/32 Dia.)
4	15691	1	Compression Spring (1/4 O.D. X 5/8 Lg.)
5	200796	1	Adapter
6	308430	1	Unloading Valve Fitting
7	214694	1	Compression Spring (1/2 O.D. X 2-1/8 Lg.)
8	214692	1	Disc
9	250800	1	Dowel Pin
10	15174	1	Backup Washer (5/16 X 3/16 X 3/64)
11	10265	1	O-ring (5/16 X 3/16 X 1/16)
12	250954	1	Piston
13	11566	1	Pin (Note: Place loose in body [Item#14].)
14	64343	1	End Plate
15	16747	7	Screw (1/4-28 UNF X 1-3/4 Lg.; See illustration below)
16	10375	2	Steel Ball (1/4 dia.)
17	201998	1	Sleeve
18	14431	1	Compression Spring (3/16 O.D. X 3/4 Lg.)
19	12571	1	Pin
20	12042	1	Copper Washer (9/16 X 3/8 X 1/32)
21	29690	1	Screw
22	24549	4	Spring Guide
23	10445	4	Compression Spring (5/32 O.D. X 3/4 Lg.)
24	20775	2	Piston
25	12223	4	Ball (3/16 Dia.)
26	41006	1	Barrel
27	41007	1	Valve Head

BOLT TIGHTENING SEQUENCE

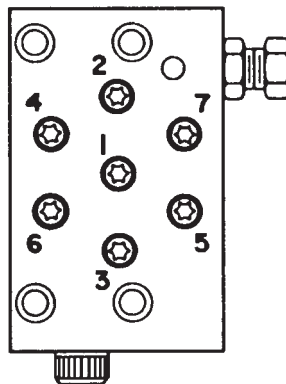

NOTE: Assemble in sequence shown. Lubricate under head on threads. Torque to 170 in. lbs.

MOTOR CONTROL ASSEMBLY FOR P126-10

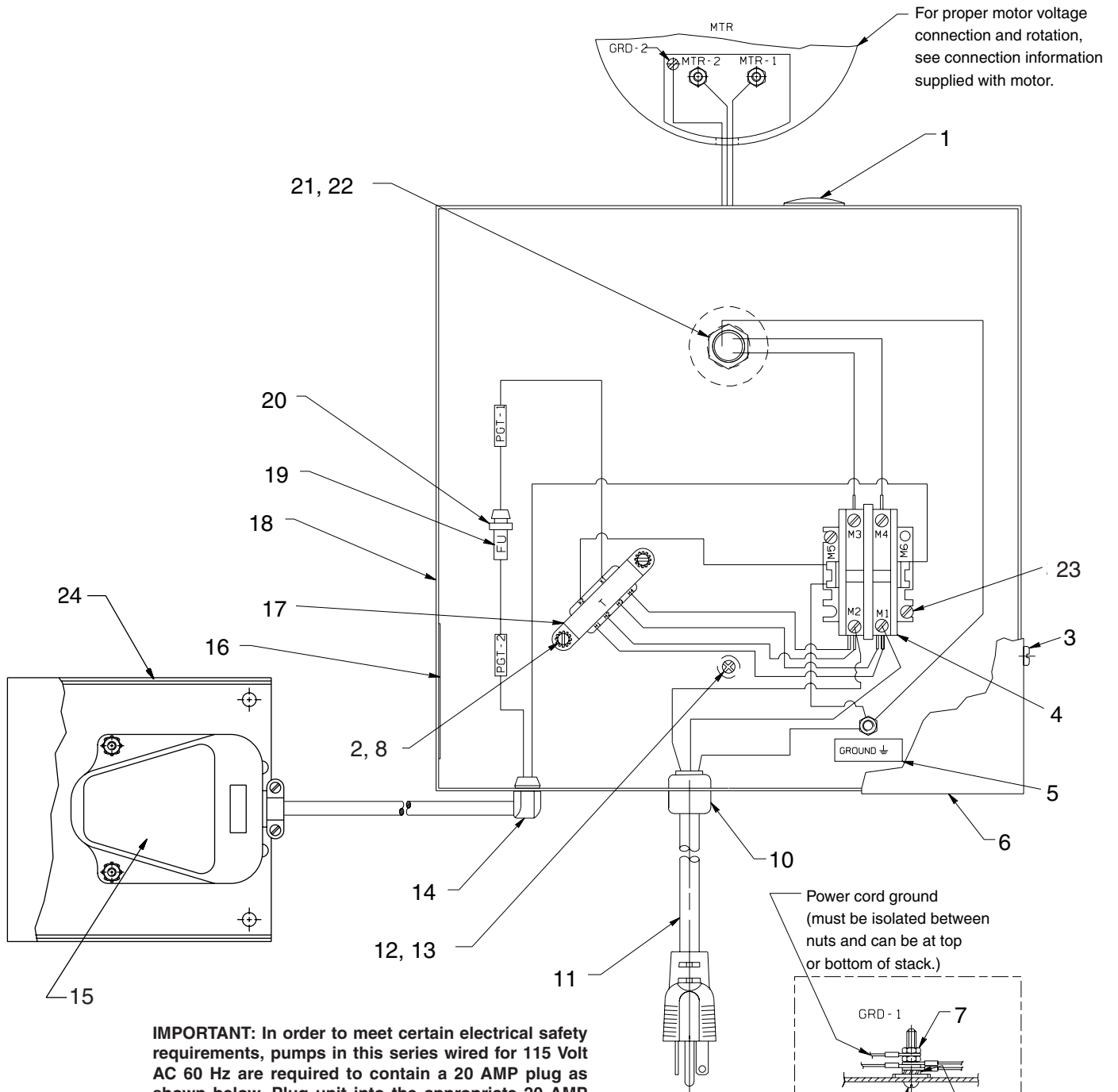

IMPORTANT: In order to meet certain electrical safety requirements, pumps in this series wired for 115 Volt AC 60 Hz are required to contain a 20 AMP plug as shown below. Plug unit into the appropriate 20 AMP electrical female receptacle. Do not modify the pump power cord or plug in any way - doing so will VOID the product warranty on any electrical components.

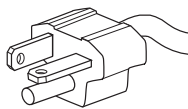

20 AMP PLUG

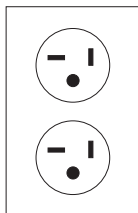

20 AMP RECEPTACLE

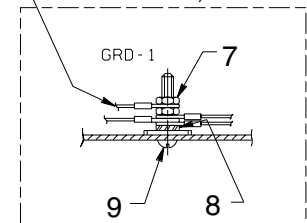

NOTE: Serrated lockwasher must be adjacent to metal box. More washers can be used if desired.

Item No.	Part No.	No. Req'd	Description
1	17782	1	Snap Plug
2	11539	2	Machine Screw (#10-24 X 1/4 Lg.)
3	14812	4	Tapping Screw (#8-18 X 3/8 Lg.)
4	420718-4	1	Contacto (2-pole)
5	205189	1	Ground Decal
6	43126BL20	1	Control Box Cover
7	10197	2	Nut (#10-24 UNC)
8	11108	3	Lockwasher (#10 External Tooth)
9	11856	1	Machine Screw (#10-24 X 1" Lg.)
10	210112	1	Strain Relief Bushing
11	350155	1	Cord Set
12	13532	1	Tapping Screw (#8-32 X 3/8 Lg.)
13	206857	1	Plain Washer (Special)
14	12176	1	Relief Bushing

Item No.	Part No.	No. Req'd	Description
15	10461	1	Foot Switch
16	250150	1	Decal
17	305665	1	Transformer
18	51218BL20	1	Electrical Control Box
19	206962	1	Fuse (3 amp)
20	16887	1	Fuse Holder
21	11202	1	Nipple
22	212434	1	Washer
23	10166	2	Machine Screw (#10-24 X 1/2 Lg.)
24	16339	1	Foot Switch Guard

PARTS INCLUDED BUT NOT SHOWN

200188	1	Warning Decal
--------	---	---------------

**ELECTRIC SCHEMATIC
FOR P126-10**

115 & 230 Volt, 60 Hz.; Single Phase



WARNING

To help avoid personal injury, all electrical work must be done by a qualified electrician.

North American & International Color Codes

Conductors	North American	International
Line	Black	Brown
Neutral	White	Blue
Ground	Green	Green/Yellow

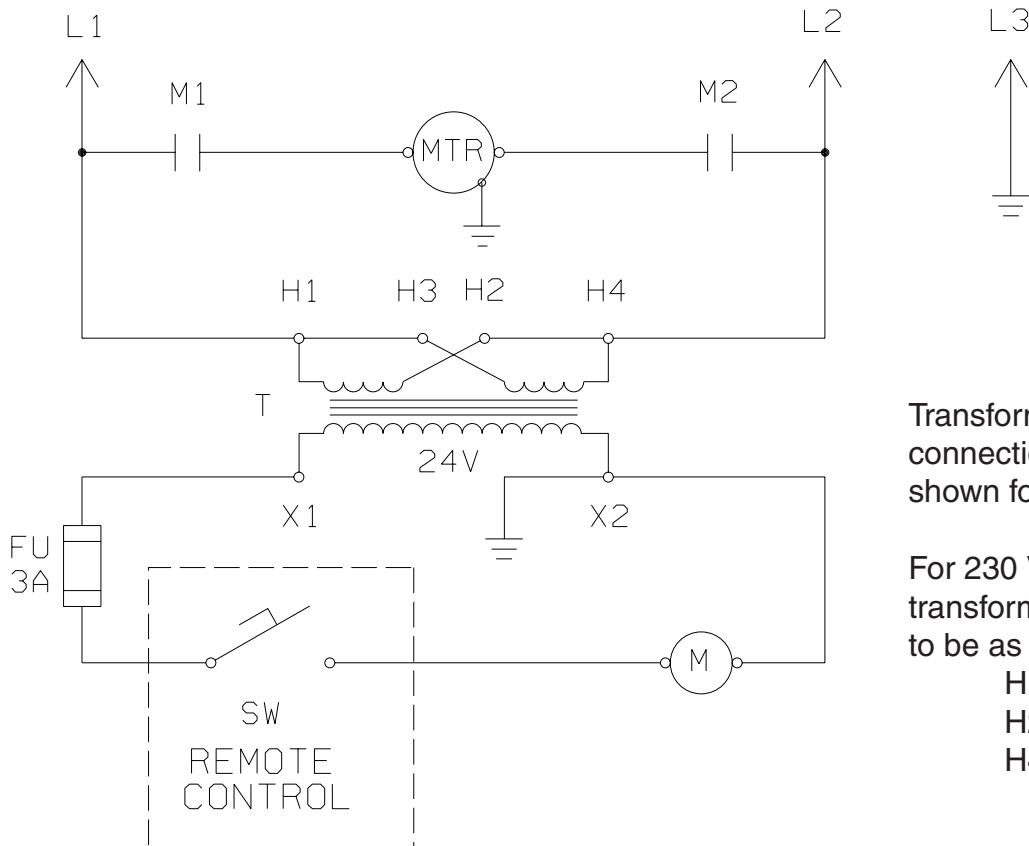

Transformer connections are as shown for 115 V., 60 Hz.

For 230 V., 60 Hz. units, transformer connections to be as follows:

- H1 to L1
- H2 to H3
- H4 to L2

MOTOR CONTROL ASSEMBLY FOR P126-10-50-220

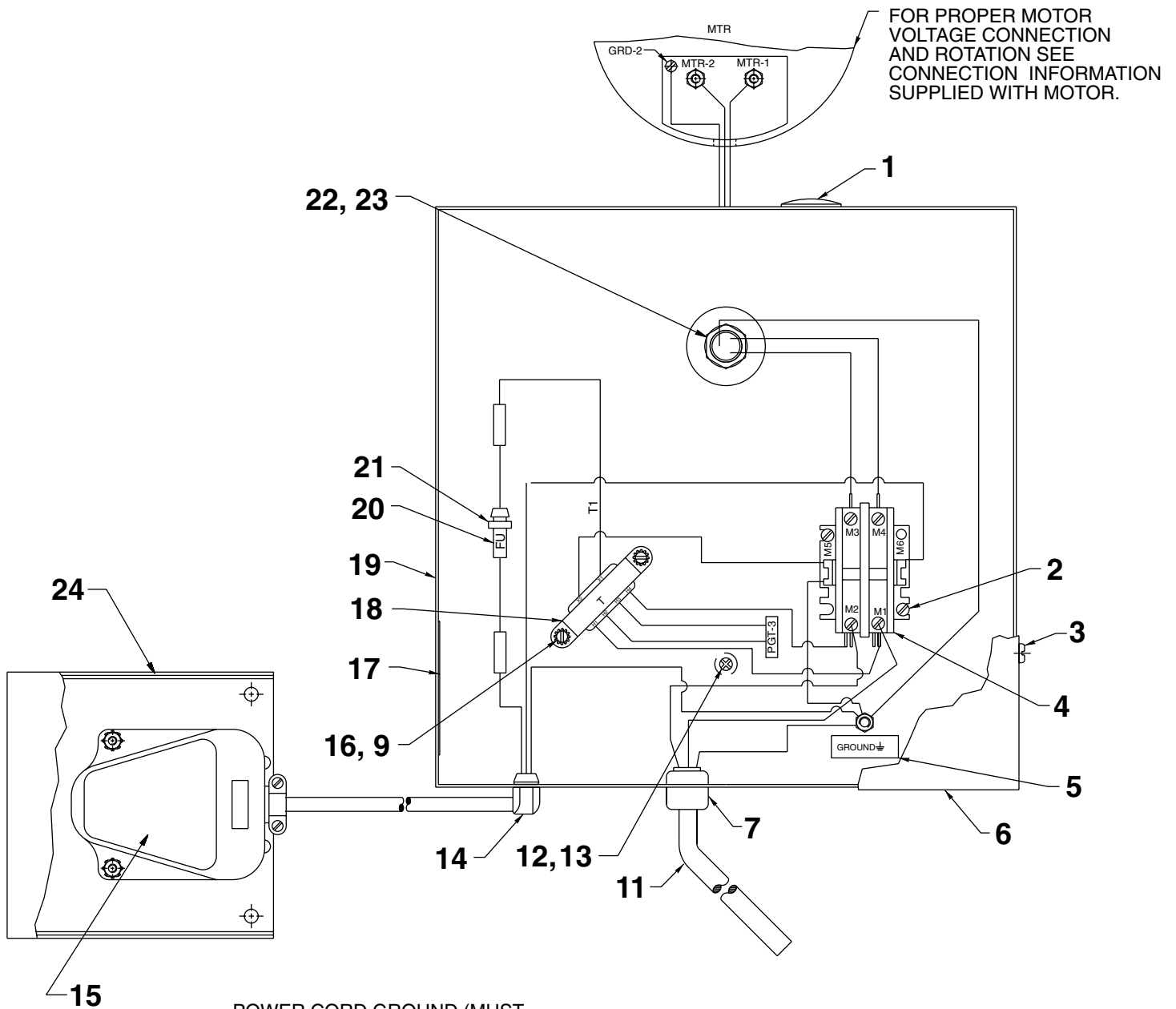

POWER CORD GROUND (MUST BE ISOLATED BETWEEN NUTS AND CAN BE AT TOP OR BOTTOM OF STACK.)

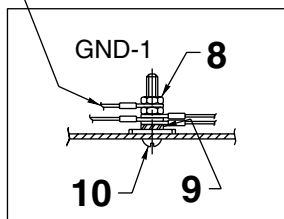

NOTE: SERRATED LOCK WASHER MUST BE ADJACENT TO METAL BOX, MORE WASHERS CAN BE USED IF DESIRED.

Item No.	Part No.	No. Req'd	Description	Item No.	Part No.	No. Req'd	Description
1	17782	1	Snap Plug	13	206857	1	Washer (For #10 bolt)
2	10166	2	Machine Screw (#10-24 X 1/2 Lg.)	14	12176	1	Relief Bushing
3	14812	4	Tapping Screw (#8-18 X 3/8 Lg.)	15	10461	1	Remote Foot Control
4	420718-4	1	Contactora (2 Pole)	16	11539	2	Machine Screw (#10-24 X 1/4 Lg.)
5	205189	1	Ground Decal	17	250150	1	Warning Decal
6	43126WH2	1	Control Box Cover	18	305665	1	Transformer
7	210112	1	Relief Bushing	19	51218WH2	1	Electrical Control Box
8	10197	2	Nut (#10-24 UNC)	20	206962	1	Fuse, (3 Amp 250 V)
9	11108	3	Lockwasher (#10 External Tooth)	21	16887	1	Fuse Holder
10	11856	1	Machine Screw (#10-24 X 1" Lg.)	22	11202	1	Nipple
11	307439	8 ft.	Cable (12/3 SJTO)	23	212434	1	Washer (For 7/8 bolt)
12	13532	1	Tapping Screw (#8-32 X 3/8 Lg.)	24	16339	1	Foot Switch Guard

ELECTRIC SCHEMATIC FOR P126-10-50-220 220 Volt, 50 Hz.; Single Phase



WARNING

To help avoid personal injury, all electrical work must be done by a qualified electrician.

North American & International Color Codes

Conductors	North American	International
Line	Black	Brown
Neutral	White	Blue
Ground	Green	Green/Yellow

