

MODEL B
DOUBLE-ACTING
HYDRAULIC CYLINDER
Max. Capacity: 103.1 Tons At 10,000 PSI

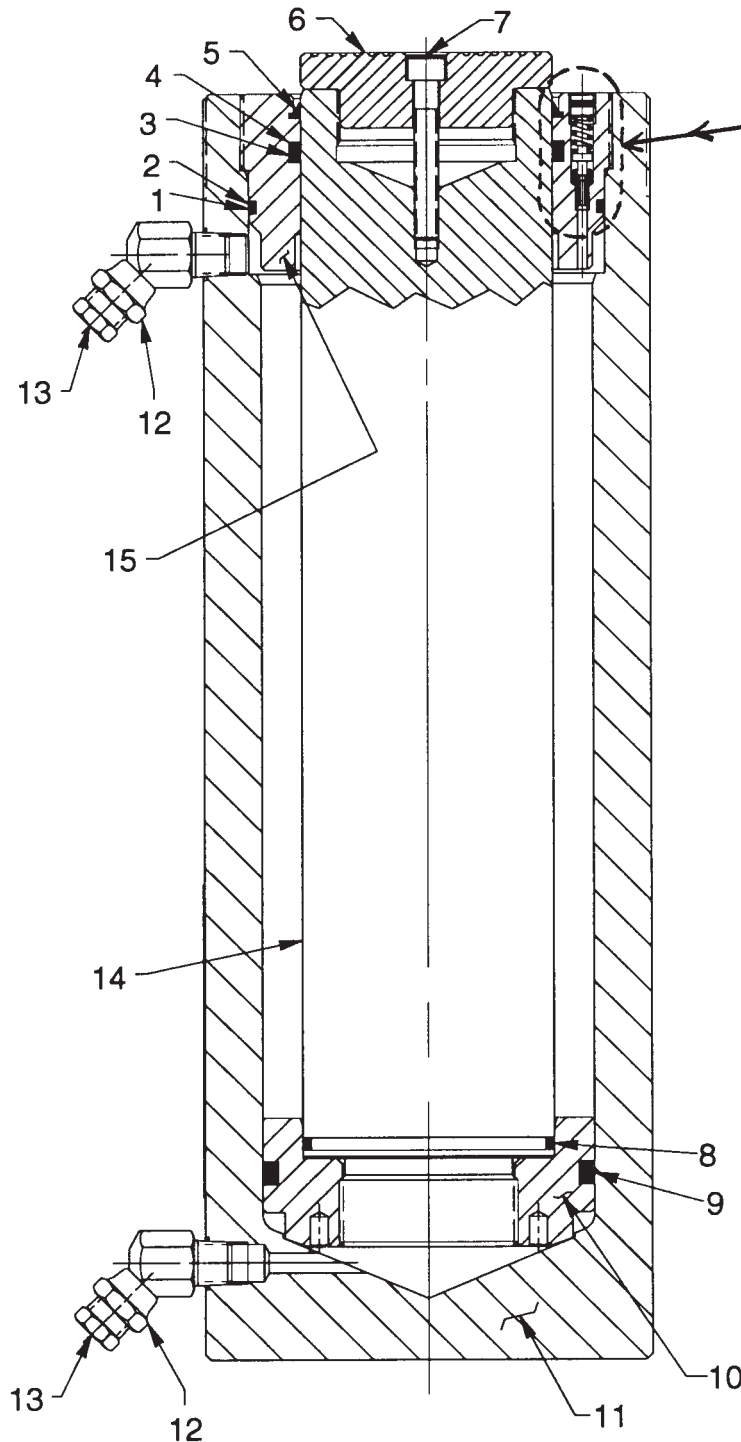

Double-acting
Cylinder
Relief Valve

See important

! DANGER

statement
on page 2



DANGER : To help avoid possible serious personal injury or death,

- In the event that the cylinder retract port is ever restricted or plugged, a double-acting cylinder relief valve will help prevent excessive pressure from building in the cylinder. **DO NOT** attempt to adjust or service this relief valve! If oil leakage is detected from this relief valve, discontinue use of the cylinder immediately and contact Power Team or OTC Technical Services. Only Power Team or OTC Authorized Hydraulic Service Centers should service this relief valve.

Item No.	Part No.	No. Req'd	Description
1	*10299	1	O-ring (5-1/2 x 5-1/4 x 1/8, -252)
2	*19270	1	Backup Washer (5-1/2 x 5-1/4 x .048, -252)
3	*19178	1	U-cup, (pre-2004)
	*19178-DEEP	1	U-cup, (post-2004)
4	*19337	1	Backup Washer (4-1/8 x 3-7/8 x .070, -344)
5	*205775	1	Rod Wiper
6	38408	1	Serrated Insert
7	10435	1	Cap Screw (3/8-16 UNC x 2-1/2 Lg.)
8	*11924	1	O-ring (3-7/8 x 3-5/8 x 1/8, -239)
9	*19207	1	T-seal with Backup Ring
10	43271	1	Piston Head (Use Loctite No. 277 when assembling piston head to piston rod [Item #1]. Torque to 200 ft. lbs.)
11	64640	1	Cylinder Body
12	10648	2	45° Elbow Fitting
13	250952	2	Pipe Plug
14	51290	1	Piston Rod
15	51289	1	Retainer Nut, (pre-2004) (Torque to 150 ft. lbs. min.)
	51289-DEEP	1	Retainer Nut, (post-2004) (Torque to 150 ft. lbs. min.)

PARTS INCLUDED BUT NOT SHOWN

*37782	1	Warning Decal
350950	1	Trade Name Decal

Part numbers marked with an asterisk (*) are contained in Repair Kit No. 3000120

Refer to any operating instructions included with this product for detailed information about operation, testing, disassembly, reassembly, and preventive maintenance.

Items found in this parts list have been carefully tested and selected. **Therefore: Use only genuine replacement parts!**

Additional questions can be directed to our Technical Services Department.