

Model B
C-FRAME PRESS
 Max. Capacity: 11.2 Ton at 10,000 PSI

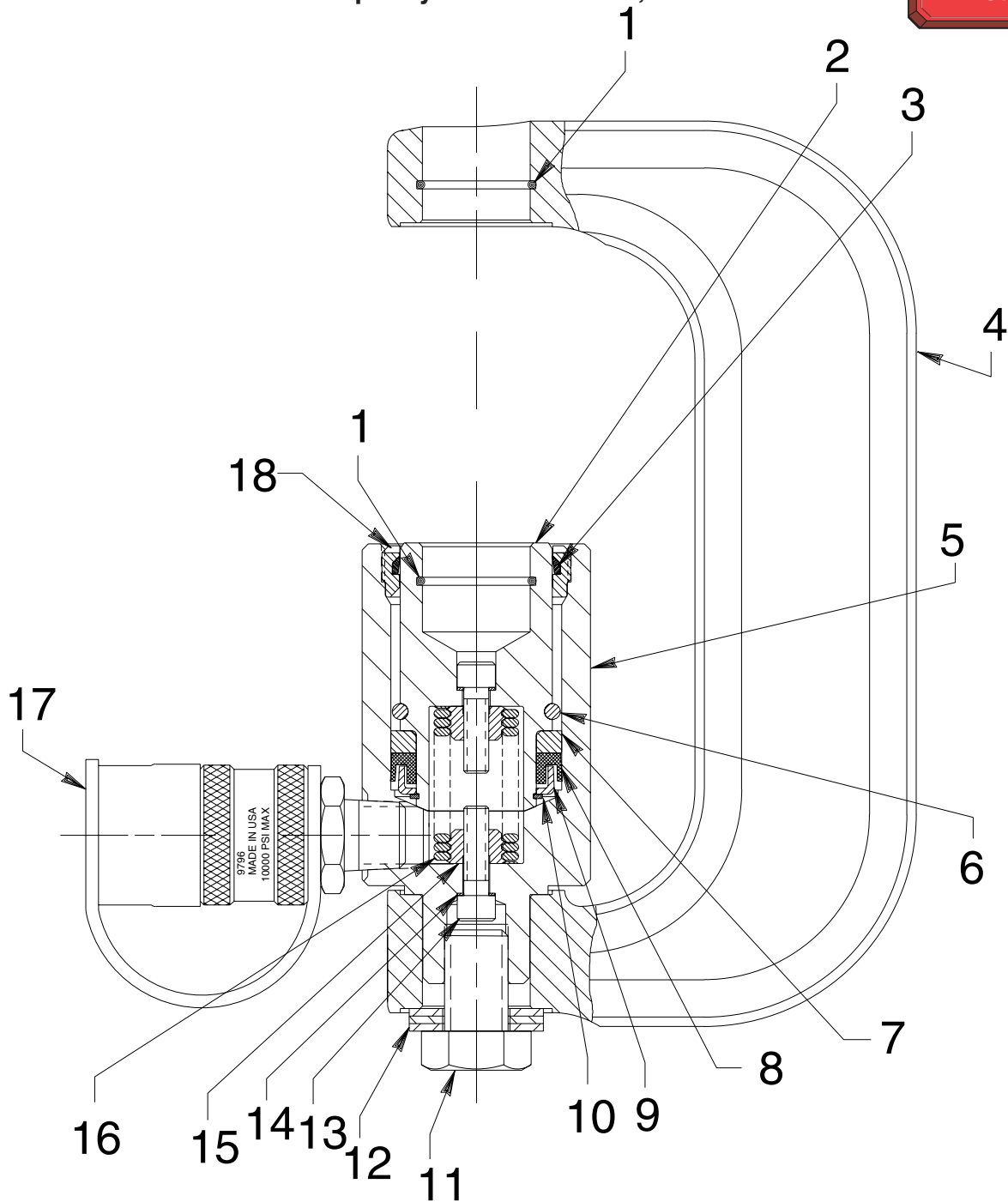

Sheet No.	1 of 1
Issue Date:	7-20-95

Parts List, Form No. 101617, Back sheet 1 of 1

Item No.	Part No.	No. Req'd	Description
1	15184	2	O-ring (1-3/16 x 1-1/16 x 1/16, -023)
2	421140	1	Piston Rod
3	*201429	1	Rod Wiper
4	58095	1	C-frame
5	420213	1	Cylinder Body
6	201433	1	Retaining Ring
7	201363	1	Piston Head (Assemble with groove toward shoulder.)
8	*16067	1	U-cup
9	201359	1	Slip Retainer
10	*16076	1	Retaining Ring
11	17124	1	Cap Screw (5/8-18 UNF x 1" Lg.)
12	13324	3	Plain Washer (Type A)
13	10012	2	Cap Screw (1/4-20 x 7/8 Lg.; Torque to 90/110 in. lbs.)
14	*10442	2	Copper Washer
15	204414	2	Spring Retainer
16	204249	1	Extension Spring (Stretch, clean, & lubricate before assembly. Assemble flush with spring retainer ends.)
17	9796	1	Quick Coupler
18	351030	1	Retainer Nut (Torque to 100/110 in. lbs.)

PARTS INCLUDED BUT NOT SHOWN

212064	1	Warning Decal
KMT250376	1	Trade Name Decal

Part numbers marked with an asterisk (*) are contained in Repair Kit No. 300116.

