

Parts List for:

61869	P157-LUAM	P159-GRC
64662	P157N	P159-LANCO
64663	P157-SAUBER	P159-PARKER
P157	P157V	P159-PFAFF
P157-AMKUS	P159	P159E
P157E	P159-AW	P159N
		P159V

MODEL C TWO-STAGE HYDRAULIC HAND PUMP TWO-WAY VALVE

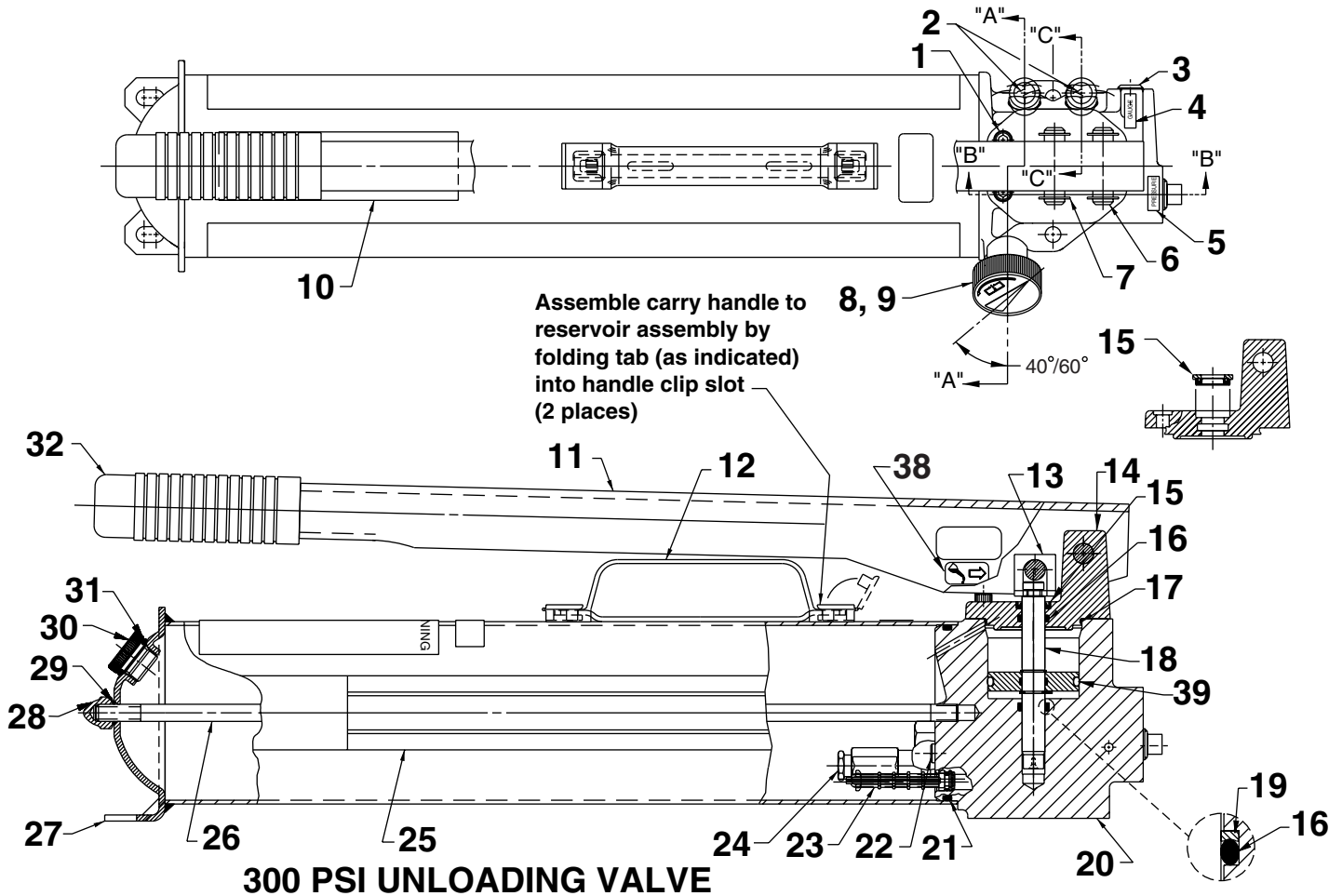

1000 & 1400 PSI UNLOADING VALVE

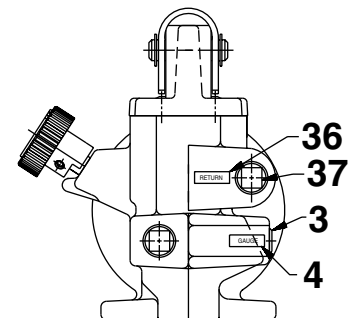
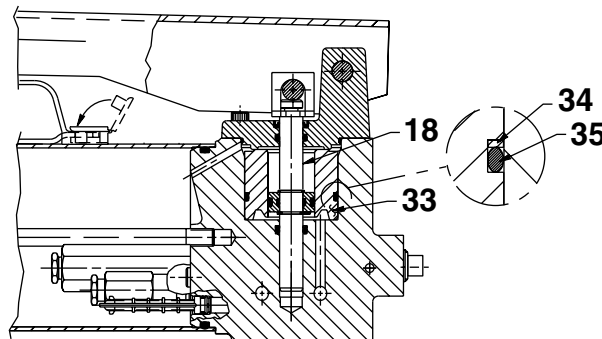

END VIEW OF
P157-AMKUS ONLY

WARNING
To help prevent personal injury, all repairs **MUST** be performed by a qualified person trained in the repair of hydraulic equipment.

Parts List, Form No. 101796, Back sheet 1 of 3

Item No.	Part No.	No. Req'd	Description
1	251564	4	Cap Screw (1/4-20 UNC x 3/4 Lg.; Torque to 200 in. lbs.)
2	■†*215907	2	Decal (DO NOT REMOVE)
3	14972	1	Plug (1/4 NPTF)
4	215300	1	Decal (GAUGE)
5	215301	1	Decal (PRESSURE)
6	211742	2	Dowel Pin
7	211743	4	Retaining Ring (For 7/16" shaft)
8	351087	1	Knob (Note: Screw in valve stem until seated [bottomed out]. Then position knob as shown approximately 1/16" from casting surface.)
9	10556	2	Set Screw (Torque to 50/70 in. lbs.)
10	■*305977	1	Warning Decal (For all except P159-PFAFF)
11	61806OR9	1	Handle (For P157, P159-PARKER, P159, & P159-LANCO)
	61806BK2	1	Handle (For P159-GRC)
	61806BL2	1	Handle (For 61869)
	61806GY6	1	Handle (For P159-PFAFF)
	61806YE3	1	Handle (For P157-LUAM & P157-AMKUS)
	61806GY14	1	Handle (For P157-SAUBER)
	47417	1	Handle Assembly (For 64662, 64663 & P159-AW)
12	58048	1	Carry Handle
13	350923	1	Piston Clip
14	58485WH2	1	Pump Body Cap (Iron)
15	■*15092	1	Rod Wiper
	†19321	1	Rod Wiper
	•250841	1	Rod Wiper
16	■*10271	2	O-ring (11/16 x 1/2 x 3/32)
	†11445	2	O-ring (11/16 x 1/2 x 3/32)
	•19406	2	O-ring (11/16 x 1/2 x 3/32)
	■10274	2	O-ring (For P157-SAUBER)
17	■*251603	1	O-ring (2-1/8 X 2" X 1/16)
	†18985	1	O-ring (2-1/8 X 2" X 1/16)
	•251604	1	O-ring (2-1/8 X 2" X 1/16)
18	253270	1	Piston Ass'y (For P157 Series, 64662 & 64663)
	253268	1	Piston Ass'y (For P159 Series & 61869)
	351509	1	Piston Ass'y (For P157-SAUBER)
	■10658	1	O-ring (Piston; For P157-SAUBER)
	■19131	1	Backup (Piston; For P157-SAUBER)
19	*†*213987	1	O-ring Backup Washer
	■252805	1	O-ring Backup Washer (For P157-SAUBER)
20	64597	1	Pump Body
	65149	1	Pump Body (For P157-AMKUS)
	65622	1	Pump Body (For P157-SAUBER)
21	■*214693	1	O-ring (3-7/8 x 3-5/8 x 1/8)
	†19048	1	O-ring (3-7/8 x 3-5/8 x 1/8)
	•214072	1	O-ring (3-7/8 x 3-5/8 x 1/8)
22	10427	1	Plug (1/8 NPTF)
23	■*215075	1	Filter Plug
24	21278	1	High Pressure Relief Valve (Set at 10,100/10,700 PSI; P157, P159, P159-AW, P159-GRC, P159-LANCO, P159-PFAFF, 64663)
	21278-75	1	High Pressure Relief Valve (Set at 7,600/8,200 PSI; For 61869)
	21278-86	1	High Pressure Relief Valve (Set at 8,700/9,300 PSI; For 64662)
	21278-105-S	1	High Pressure Relief Valve (Set at 10,600/11,100 PSI; For P157-LUAM & P157-AMKUS)
	21278-70	1	High Pressure Relief Valve (Set at 7,100/7,700 PSI; For P159-PARKER)
25	360054	1	Trade Name Decal (For P157, P157E, P157N & P157V)
	360054	1	Trade Name Decal (For P159, P159E, P159N & P159V)
	252186	1	Trade Name Decal (For P159-PFAFF)
	251742	2	Trade Name Decal (For P159-GRC)

Note: Shaded areas reflect last revision(s) made to this form.

Item No.	Part No.	No. Req'd	Description
26	252502	1	Tie Rod
27	58915	1	Reservoir
	58916	1	Reservoir (For P157-AMKUS)
28	10842	1	Acorn Nut (Torque to 90/110 in.lbs. Fully engage acorn nut onto tie rod before torquing to body.)
29	13943	1	O-ring (1/2 X 3/8 X 1/16; Urethane)
	†11439	1	O-ring (1/2 X 3/8 X 1/16; Viton)
	•17716	1	O-ring (1/2 X 3/8 X 1/16; EPR)
30	351245	1	Fill Cap
31	10274	1	O-ring (15/16 X 11/16 X 1/8; Nitrile)
	253597	1	O-ring (15/16 X 11/16 X 1/8; Viton)
	253598	1	O-ring (15/16 X 11/16 X 1/8; EPR)
32	211769	1	Handle Grip (For all except P159-AW, 64663 & 64662)
33	308486	1	Adapter (For P157, P157-LUAM, P157E, P157N, P157V, 64662, 64663 & P157-AMKUS)
34	■*†19137	1	O-ring Backup Washer (2" x 1-13/16 x 3/64; For P157, P157-LUAM, P157E, P157N, P157V, 64662, 64663 & P-157-AMKUS)
35	■*10913	1	O-ring (2" x 1-13/16 x 3/32; For P157, P157-LUAM, P157N, 64662, 64663 & P157-AMKUS)
	•14287	1	O-ring (For P157E)
	†19015	1	O-ring (For P157V)
36	201746	1	Decal (Return)
37	11127	1	Plug Fitting (3/8 NPTF)
38	253234	1	Decal, Oil Pivot Pins
39	*10294	1	O-ring (2.00 x 1.75 Nitrile)
	†11447	1	O-ring (2.00 x 1.75 Viton)
	•215366	1	O-ring (2.00 x 1.75 EPR)

PARTS INCLUDED BUT NOT SHOWN

10029	4	Cap Screw (5/16-18 UNC x 3/4 Lg.; For 64662 & 64663)
10474	1	Fitting (For 64662)
36890	1	Hose Assembly (For 64662)
†205724	1	Decal (Viton seals)
•250328	1	Decal (EPR seals)
251943	1	Decal (For P159-PFAFF)

Part numbers marked with an asterisk (*) are contained in Standard Repair Kit No. 300942.

Part numbers marked with a dagger (†) are contained in Viton Seal Kit No. 300690.

Part numbers marked with a bullet (•) are contained in EPR Seal Kit No. 300691.

Part numbers marked with a square (■) are contained in Standard Repair Kit No. 300926 (for P159-SAUBER only).

SECTION VIEWS

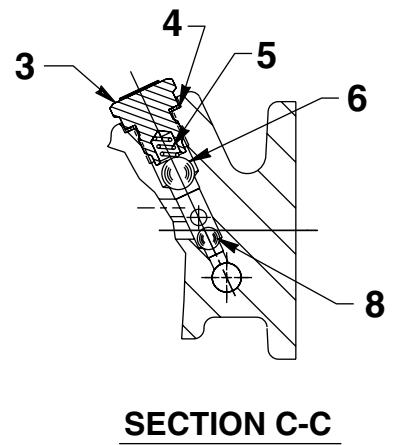
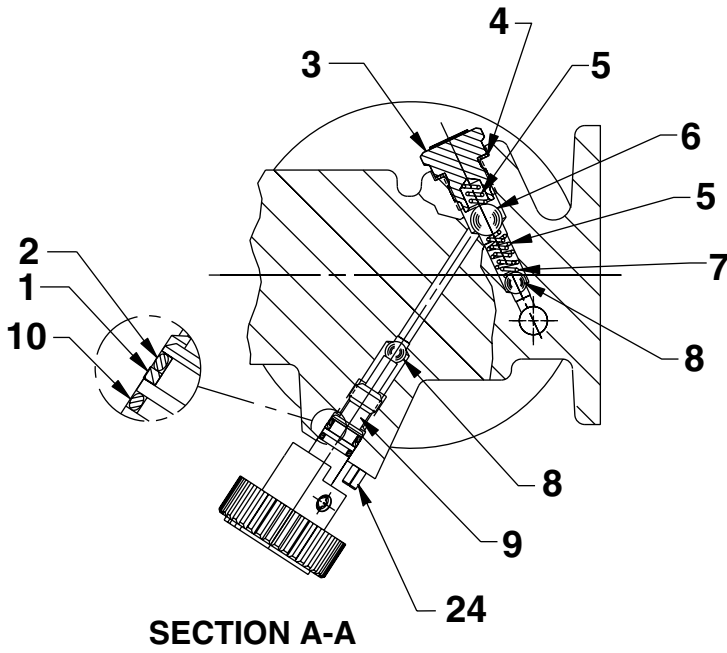

1000 & 1400 PSI UNLOADING VALVE

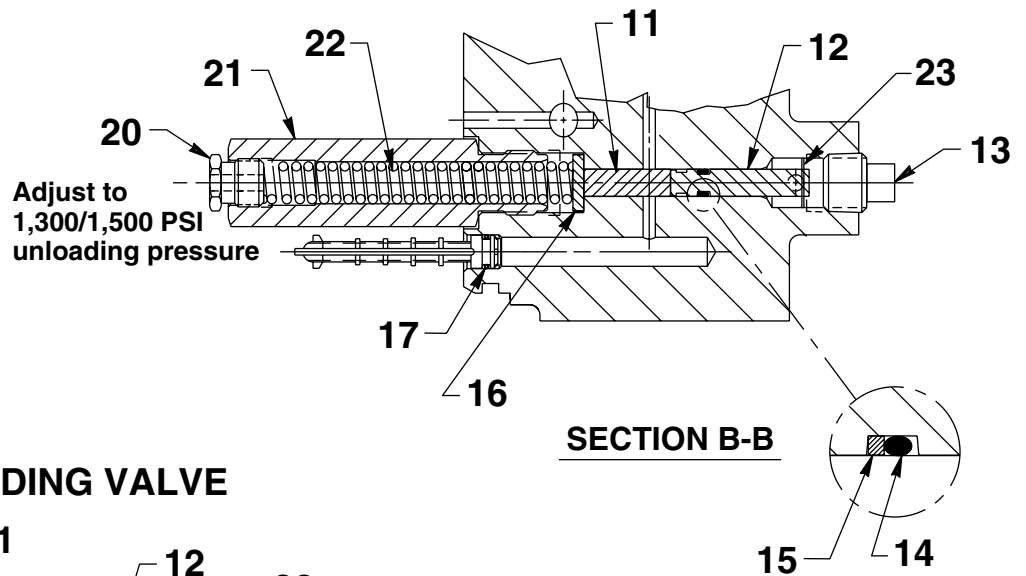

300 PSI UNLOADING VALVE

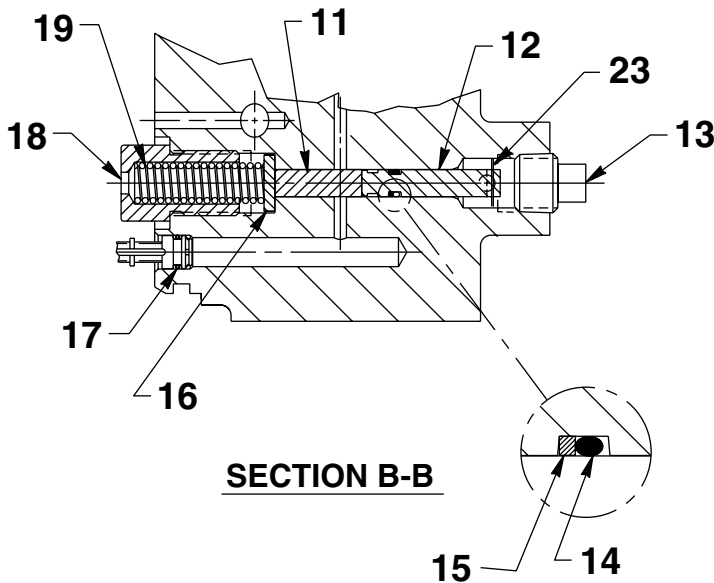

Item No.	Part No.	No. Req'd	Description
1	*†•15085	1	O-ring Backup Washer (7/16 x 5/16 x 3/64)
2	■*10267	1	O-ring (7/16 x 5/16 x 1/16)
	†18974	1	O-ring
	•13472	1	O-ring
3	351952	2	Valve Screw (Torque to 350/370 in. lbs.)
4	■*14874	2	Copper Washer (.700 x 1/2 x 1/32 thk.)
5	■*10444	3	Compression Spring (3/16 I.D. x 13/32 Lg.)
6	■*10378	2	Steel Ball (3/8 Dia.)
7	■*211797	1	Compression Spring (5/32 O.D. x 5/8 Lg.)
8	■*10375	3	Steel Ball (1/4 dia.)
9	350185	1	Release Valve Screw
10	14763	1	O-ring (.43 x .32; Urethane)
11	14588	1	Dowel Pin
12	252275	1	Unloading Valve Piston Kit (Includes #252273 retaining ring [Item # 23] and #214691 unloading valve piston)
13	11127	1	Plug (3/8 NPTF)
14	■*10265	1	O-ring (5/16 x 3/16 x 3/64)
	†11437	1	O-ring
	•17714	1	O-ring
15	■*†•15174	1	O-ring Backup Washer (5/16 x 3/16 x 3/64)
16	214692	1	Unloading Valve Washer
17	■*12557	1	O-ring (11/32 x 7/32 x 1/16)
	†18973	1	O-ring
	•215375	1	O-ring
18	308430	1	Spring Retainer (For P159, P159-AW, P159-GRC, P159-LANCO, P159-PARKER, P159-PFAFF, P159E, P159N, P159V & 61869)
19	214694	1	Compression Spring (For P159, P159-AW, P159-GRC, P159-LANCO, P159-PARKER, P159-PFAFF, P159E, P159V, P159N, 61869)
20	305912	1	Valve Adjusting Screw (For P157, P157-LUAM, P157E, P157N, P157V, 64662, 64663 & P157-AMKUS)
21	308488	1	Spring Retainer (For P157, P157-LUAM, P157E, P157N, P157V, 64662, 64663 & P157-AMKUS)
22	214808	1	Compression Spring (15/32 O.D. x 4-7/16 Lg.; For P157, P157-LUAM, P157E, P157N, P157V, 64662, 64663 & P157-AMKUS)
23	252273	1	Retaining Ring (Included in Item #12)
24	10714	1	Slotted Spring Pin (Included with pump body [Item #20 on back sheet 1 of 3].)

Part numbers marked with an asterisk (*) are contained in Standard Repair Kit No. 300942.

Part numbers marked with a dagger (†) are contained in Viton Seal Kit No. 300690.

Part numbers marked with a bullet (•) are contained in EPR Seal Kit No. 300691.

Part numbers marked with a square (■) are contained in Standard Repair Kit No. 300926 (for P159-SAUBER only).

Refer to any operating instructions included with this product for detailed information about operation, testing, disassembly, reassembly, and preventive maintenance.

Items found in this parts list have been carefully tested and selected. **Therefore: Use only genuine Power Team replacement parts!**

Additional questions can be directed to our Technical Services Department.