

Parts List for:

P157D P159D Series
P157D Series P159D-PFAFF
P159D

MODEL C TWO STAGE HYDRAULIC HAND PUMP With 4-Way Valve

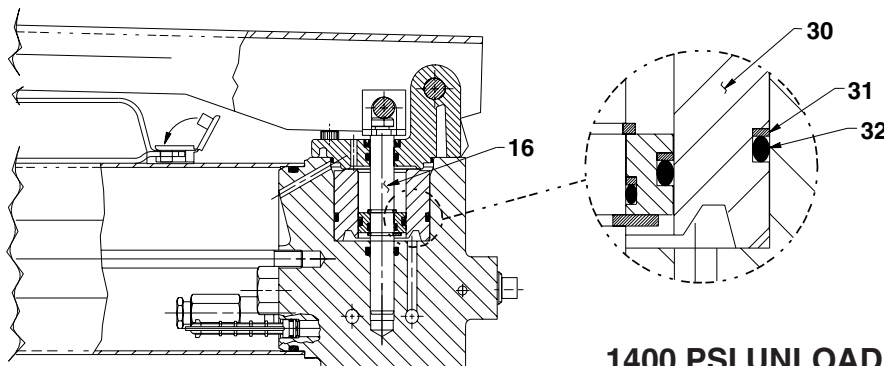
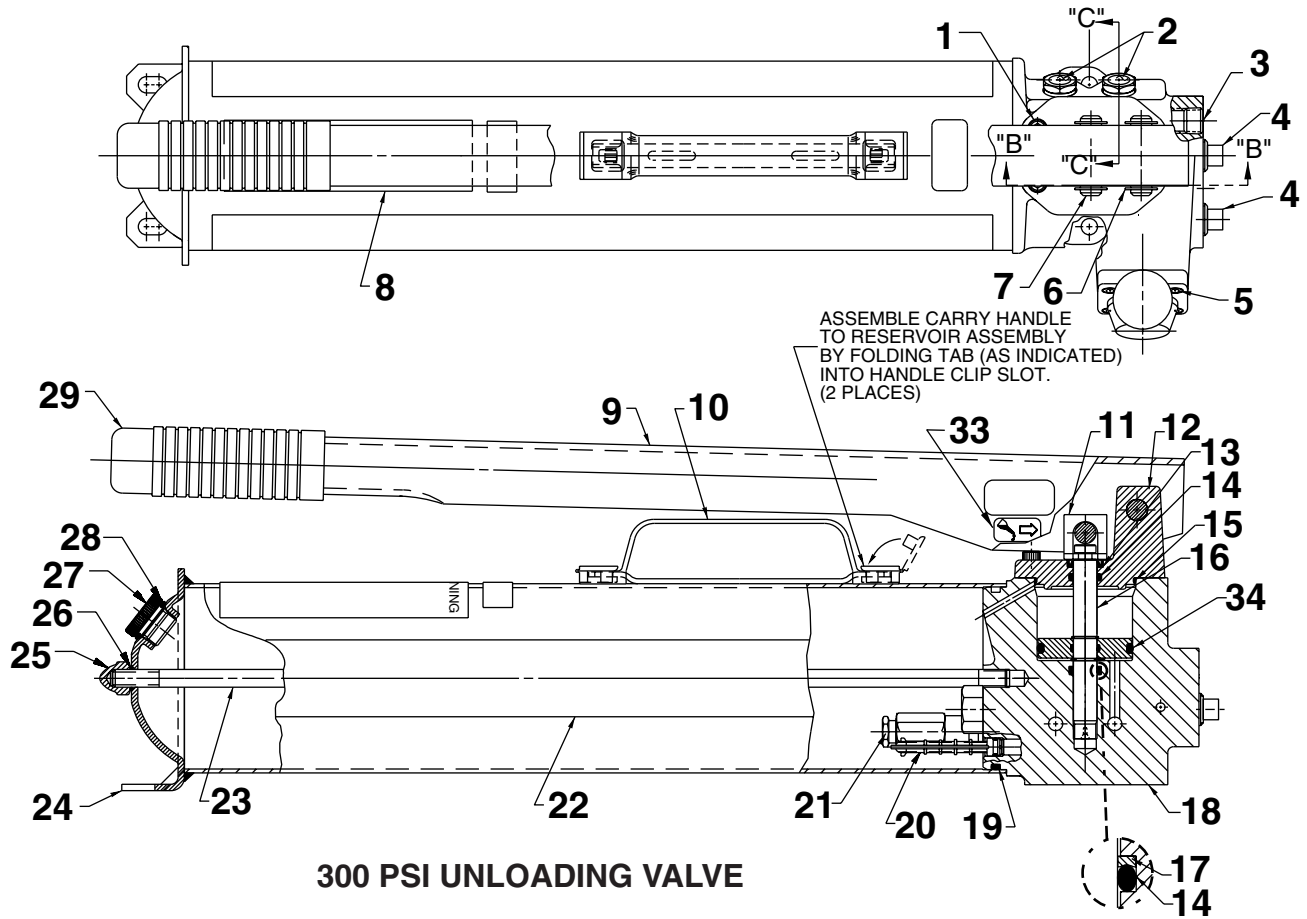

WARNING: To help prevent personal injury, all repairs **MUST** be performed by a qualified person trained in the repair of hydraulic equipment.

Parts List, Form No. 101797, Back sheet 1 of 2

Item No.	Part No.	No. Req'd	Description
1	251564	4	Cap Screw (1/4-20 UNC x 3/4 Lg.; Torque to 200 in lbs.)
2	215907	2	Decal ("DO NOT REMOVE")
3	14972	1	Plug
4	11127	2	Plug (3/8 NPTF)
5	11434	4	Cap Screw (#10-24 UNC X 1/2 Lg.)
6	211743	4	Retaining Ring (For 7/16 shaft)
7	211742	2	Dowel Pin (7/16 dia. X 1-3/4 Lg.)
8	•†*305977	1	Warning Decal
9	61806OR9	1	Handle
10	58048	1	Carry Handle
11	350923	1	Piston Clip
12	58485WH2	1	Pump Body Cap (Iron)
13	*15092	1	Rod Wiper
	†19321	1	Rod Wiper
	•250841	1	Rod Wiper
14	*10271	2	O-ring (11/16 X 1/2 X 3/32)
	†11445	2	O-ring (11/16 X 1/2 X 3/32)
	•19406	2	O-ring (11/16 X 1/2 X 3/32)
15	*251603	1	O-ring (2-1/8 x 2" x 1/16)
	†18985	1	O-ring (2-1/8 x 2" x 1/16)
	•251604	1	O-ring (2-1/8 x 2" x 1/16)
16	253270	1	Piston Assembly (For P157D, P157DE, P157DN & P157DV)
	253268	1	Piston Assembly (For P159D & P159D-PFAFF)
17	*213987	1	O-ring Backup Washer (11/16 X 1/2 X 3/64)
18	64506	1	Pump Body
19	*214693	1	O-ring (3-7/8 X 3-5/8 X 1/8)
	†19048	1	O-ring (3-7/8 X 3-5/8 X 1/8)
	•214072	1	O-ring (3-7/8 X 3-5/8 X 1/8)
20	•†*215075	1	Filter Plug

Item No.	Part No.	No. Req'd	Description
21	21278	1	Relief Valve Assembly (See note below)
22	360054	1	Trade Name Decal
23	252502	1	Tie Rod
24	58915	1	Reservoir Assembly
25	10842	1	Acorn Nut (Torque to 90/110 in. lbs. Fully engage acorn nut onto tie rod before torquing to body.)
26	13943	1	O-ring (1/2 X 3/8 X 1/16; Urethane)
	†11439	1	O-ring (1/2 X 3/8 X 1/16)
	•17716	1	O-ring (1/2 X 3/8 X 1/16)
27	351245	1	Filler Cap
28	10274	1	O-ring (.87 x .68; Nitrile)
	253597	1	O-ring (.87 x .68; Viton)
	253598	1	O-ring (.87 x .68; EPR)
29	211769	1	Handle Grip
30	308486	1	Adapter (For P157D)
31	•†*19137	1	O-ring Backup Washer (2" X 1 13/16 X 3/64; For P157D)
32	*10913	1	O-ring (2" X 1-13/16 X 3/32; For P157D)
	†19015	1	O-ring (2" X 1-13/16 X 3/32)
	•14287	1	O-ring (2" X 1-13/16 X 3/32)
33	253234	1	Decal, Oil Pivot Pins
34	*10294	1	O-ring (2.00 x 1.75 Nitrile)
	†11447	1	O-ring (2.00 x 1.75 Viton)
	•215366	1	O-ring (2.00 x 1.75 EPR)

PARTS INCLUDED BUT NOT SHOWN

†205724	1	Decal (Viton seals)
308588	1	Optional Handle Retainer
•250328	1	Decal (EPR seals)

Part numbers marked with an asterisk (*) are contained in Standard Repair Kit No. 300692.

Part numbers marked with a dagger (†) are contained in Viton Seal Kit No. 300693.

Part numbers marked with a bullet (•) are contained in EPR Seal Kit No. 300694.



NOTE

Standard relief valves are set at 10,100/10,700 PSI.

Relief valves pre-set at special settings are available.

Refer to your pump model number or contact Power Team Technical Services.

Note: Shaded areas reflect last revision(s) made to this form.



SECTION VIEWS

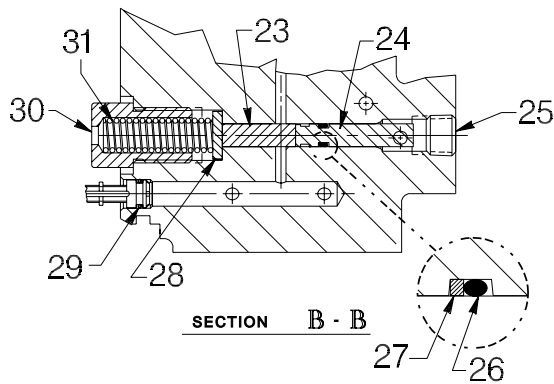
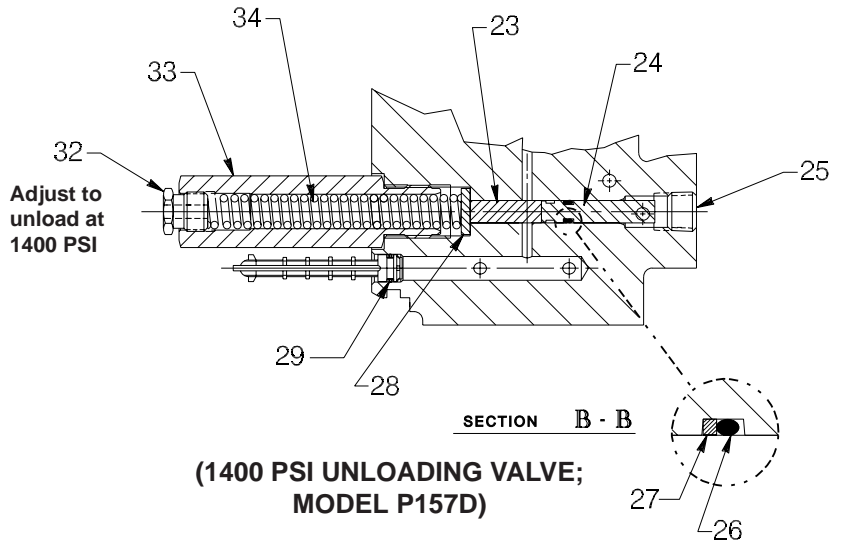
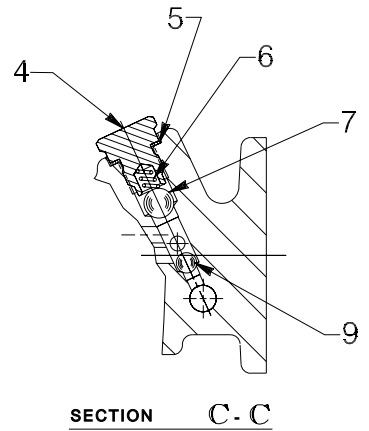
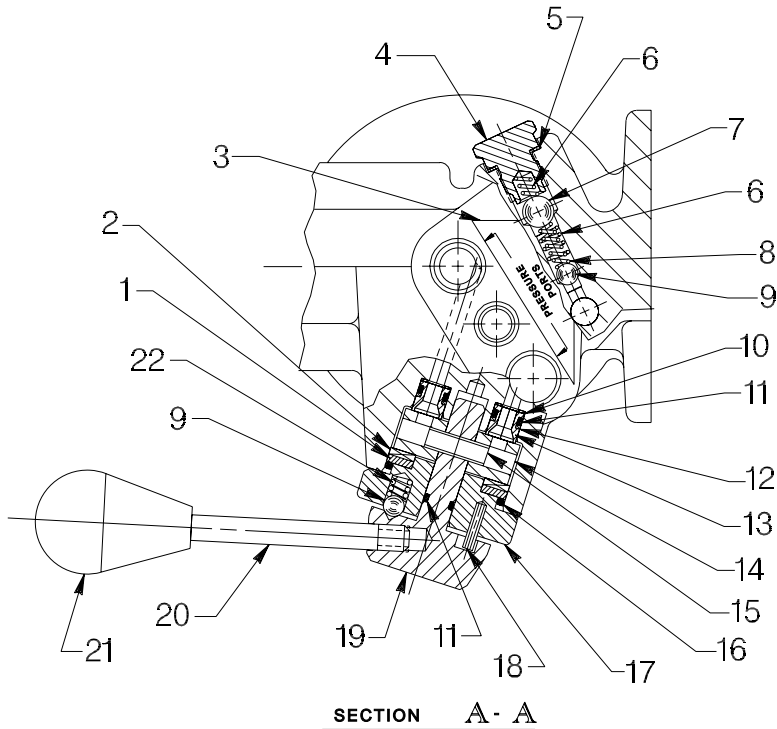

(300 PSI UNLOADING VALVE;
MODELS P159D)

Parts List, Form No. 101797, Back sheet 2 of 2

Item No.	Part No.	No. Req'd	Description
1	12189	1	Needle Thrust Bearing Race
2	12188	1	Needle Thrust Bearing
3	215302	1	Decal
4	351952	2	Valve Screw (Torque to 350/370 in. lbs.)
5	*14874	2	Copper Washer (.700 X 1/2 X 1/32 Thk.)
6	*10444	3	Compression Spring (3/16 I.D. X 13/32 Lg.)
7	*10378	2	Steel Ball (3/8 dia.)
8	*211797	1	Compression Spring (5/32 O.D. X 5/8 Lg.)
9	*10375	3	Steel Ball (1/4 dia.)
10	*12187	3	Spring Washer (#10 style)
11	*10266	4	O-ring (3/8 X 1/4 X 1/16)
	†11438	4	O-ring (3/8 X 1/4 X 1/16)
	•17715	1	O-ring (3/8 X 1/4 X 1/16)
12	•†12184	3	Backup Washer (3/8 X 1/4 X .048)
13	24570	3	Shear Seal
14	32071	1	Rotor
15	10716	1	Roll Pin (1/4 dia. X 3/4 Lg.)
16	*10930	1	O-ring (1-1/2 X 1-5/16 X 3/32)
	†19008	1	O-ring (1-1/2 X 1-5/16 X 3/32)
	•13455	1	O-ring (1-1/2 X 1-5/16 X 3/32)
17	25821	1	Cover
18	11587	1	Roll Pin (1/8 dia. X 1/2 Lg.)
19	32070	1	Stem
20	24564	1	Stud
21	12821	1	Knob
22	*12195	1	Compression Spring (1/4 O.D. X 1/2 Lg.)
23	14588	1	Dowel Pin
24	252275	1	Unloading Valve Piston Kit
25	14972	2	Plug
26	*10265	1	O-ring (5/16 X 3/16 X 1/16)
	†11437	1	O-ring (5/16 X 3/16 X 1/16)
	*17714	1	O-ring (5/16 X 3/16 X 1/16)
27	•†15174	1	O-ring Backup Washer (5/16 X 3/16 X 3/64)
28	214692	1	Disc
29	*12557	1	O-ring (11/32 X 7/32 X 1/16)
	†18973	1	O-ring (11/32 X 7/32 X 1/16)
	*215375	1	O-ring (11/32 X 7/32 X 1/16)
30	308430	1	Spring Retainer (For P159D)
31	214694	1	Compression Spring (For P159D)
32	305912	1	Valve Adjusting Screw (For P157D)
33	308488	1	Spring Retainer (For P157D)
34	214808	1	Compression Spring (15/32 O.D. X 4-7/16 Lg.; For P157D)

Part numbers marked with an asterisk (*) are contained in Standard Repair Kit No. 300692.

Part numbers marked with a dagger (†) are contained in Viton Seal Kit No. 300693.

Part numbers marked with a bullet (•) are contained in EPR Seal Kit No. 300694.



Refer to any operating instructions included with this product for detailed information about operation, testing, disassembly, reassembly, and preventive maintenance.

Items found in this parts list have been carefully tested and selected. **Therefore: Use only genuine Power Team replacement parts!**

Additional questions can be directed to our Technical Services Department.