

Parts List for:

PE302R-220
PE302R-2-220
PE303R-220

PE303R-2-220
PE304R-220
PE304R-2-220

MODEL B
ELECTRIC HYDRAULIC PUMP
Max. Capacity: 10,000 PSI



This view illustrates models with a 1-3/4 gallon reservoir.

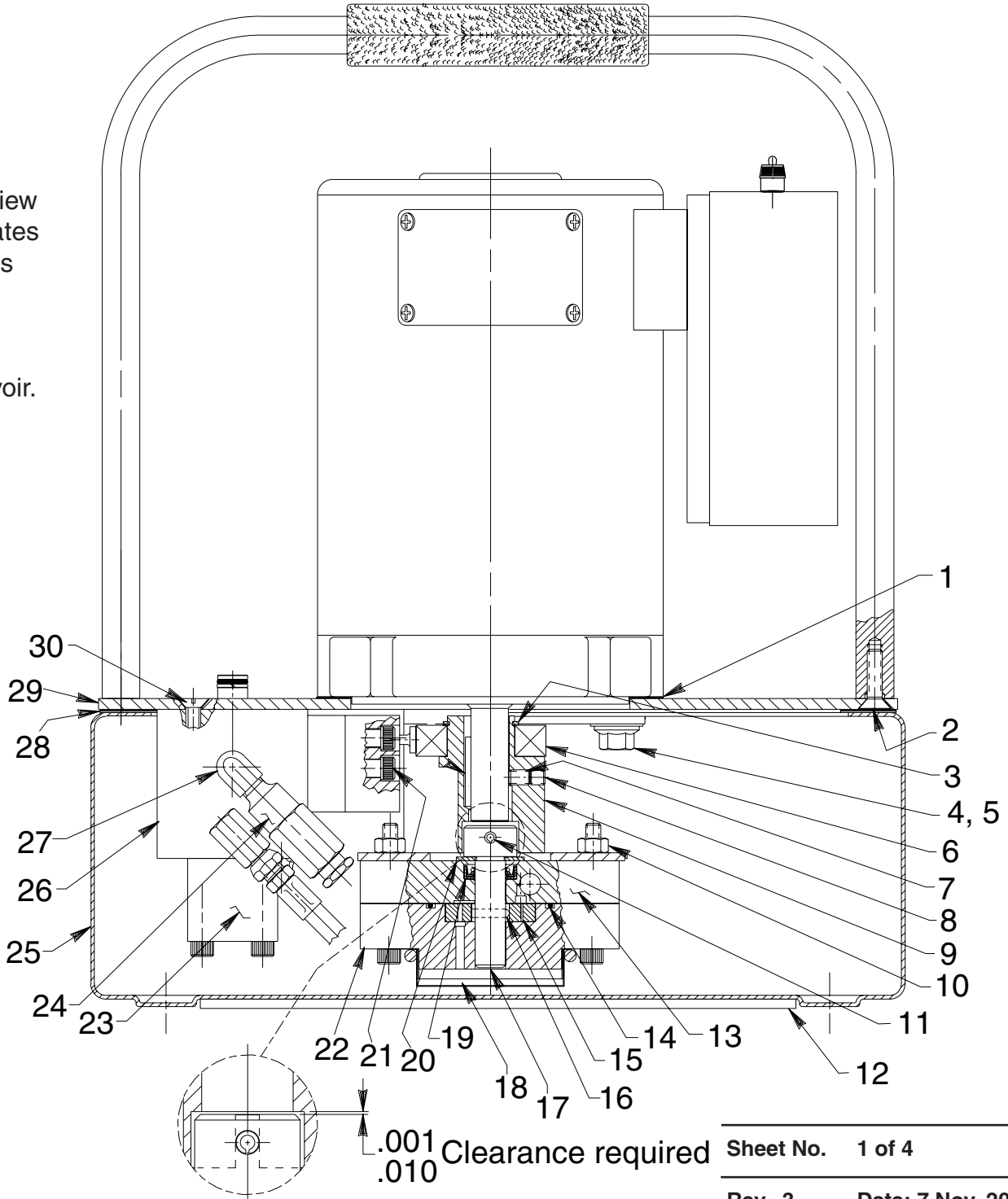

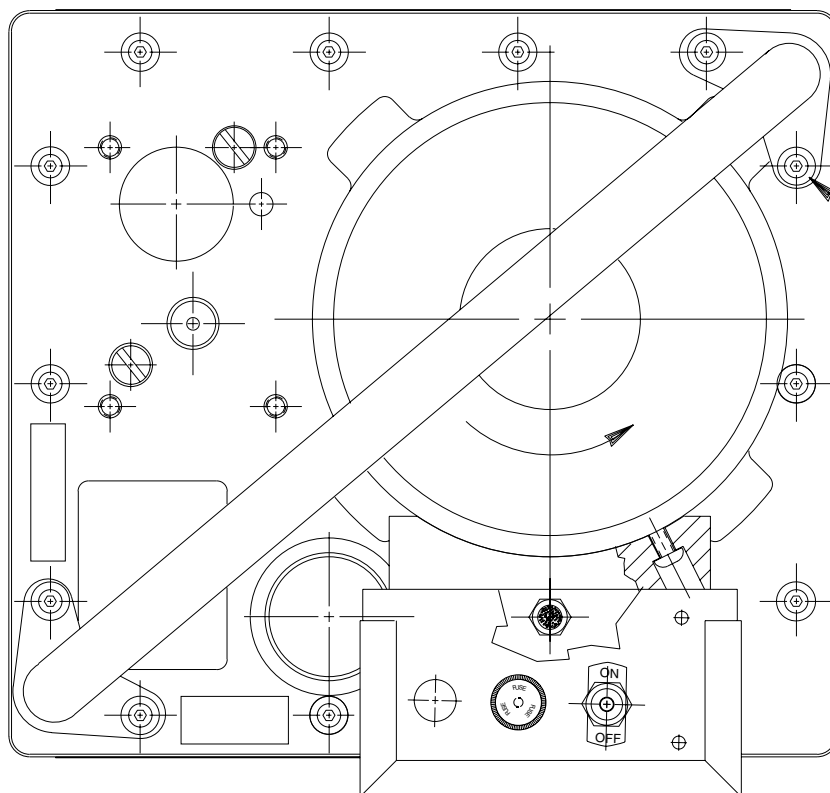

31

This view illustrates the handle orientation, and its mounting, on models with a one gallon reservoir.

Item No.	Part No.	No. Req'd	Description
1	351060	1	Motor Base Gasket
2	11529	4	Cap Screw (1/4-20 UNC x 3/4 Lg.; Apply Loctite No. 242 or equiv. For PE302R-2-220, PE303R-2-220 & PE304R-2-220)
3	209798	1	Retaining Ring
4	213663	4	Cap Screw (3/8-16 UNC X 1" Lg.)
5	10258	4	Washer (For 3/8 bolt; Torque to 230/250 in. lbs.)
6	209805	1	Ball Bearing
7	10136	1	Set Screw (1/4-20 UNC x 1/4 Lg.; Torque to 60/80 in. lbs.)
8	10519	1	Set Screw (1/4-20 UNC X 3/8 Lg.; Torque to 60/80 in. lbs.)
9	420840	1	Eccentric
10	10199	2	Hex Nut (1/4-20 UNC)
11	12298	1	Roll Pin (3/16 dia. x 1-1/2" Lg.)
12	420427	1	Rubber Pad (For PE302R-2-220, PE303R-2-220 & PE304R-2-220)
	420948	1	Rubber Pad (For PE302R-220, PE303R-220, & PE304R-220)
13	64623	1	Upper Gerotor Housing
14	10922	1	O-ring (2-1/8" X 1-15/16" X 3/32)
15	304826	1	Gerotor
16	209794	1	Gerotor Drive Pin
17	350940	1	Gerotor Shaft
18	21846	1	Filter Support
19	304830	1	Oil Seal
20	12595	1	Washer (1-1/8" X 1/2 X .077 Thk.)

Item No.	Part No.	No. Req'd	Description
21	10022	4	Screw (1/4-20 UNC X 1-1/2" Lg.; Torque to 180/200 in. lbs.)
22	64580	1	Gerotor Housing
23	350930	1	Retaining Block
24	21278	1	Relief Valve Assembly (Set at 10,100/10,700 PSI)
25	64665OR9	1	Reservoir (1 Gal. - For PE302R-220, PE303R-220, & PE304R-220)
	64241OR9	1	Reservoir (2 Gal. For PE302R-2-220, PE303R-2-220 & PE304R-2-220)
26	64612	1	Check Body
27	13229	1	Street Elbow
28	420931	1	Reservoir Gasket (For PE302R-220, PE303R-220, & PE304R-220)
	420424	1	Reservoir Gasket (For PE302R-2-220, PE303R-2-220 & PE304R-2-220)
29	64666BK2	1	Cover Plate (For PE302R-220, PE303R-220, & PE304R-220)
	64579BK2	1	Cover Plate (For PE302R-2-220, PE303R-2-220 & PE304R-2-220)
30	11529	2	Screw (1/4-20 UNC x 3/4 Lg.)
31	15911	4	Cap Screw (1/4-20 5/8 Lg.; Apply Loctite No. 242 or equiv. and torque to 60/80 in. lbs. For PE302R-220, PE303R-220, & PE304R-220)



HIGH PRESSURE PUMP ASSEMBLY

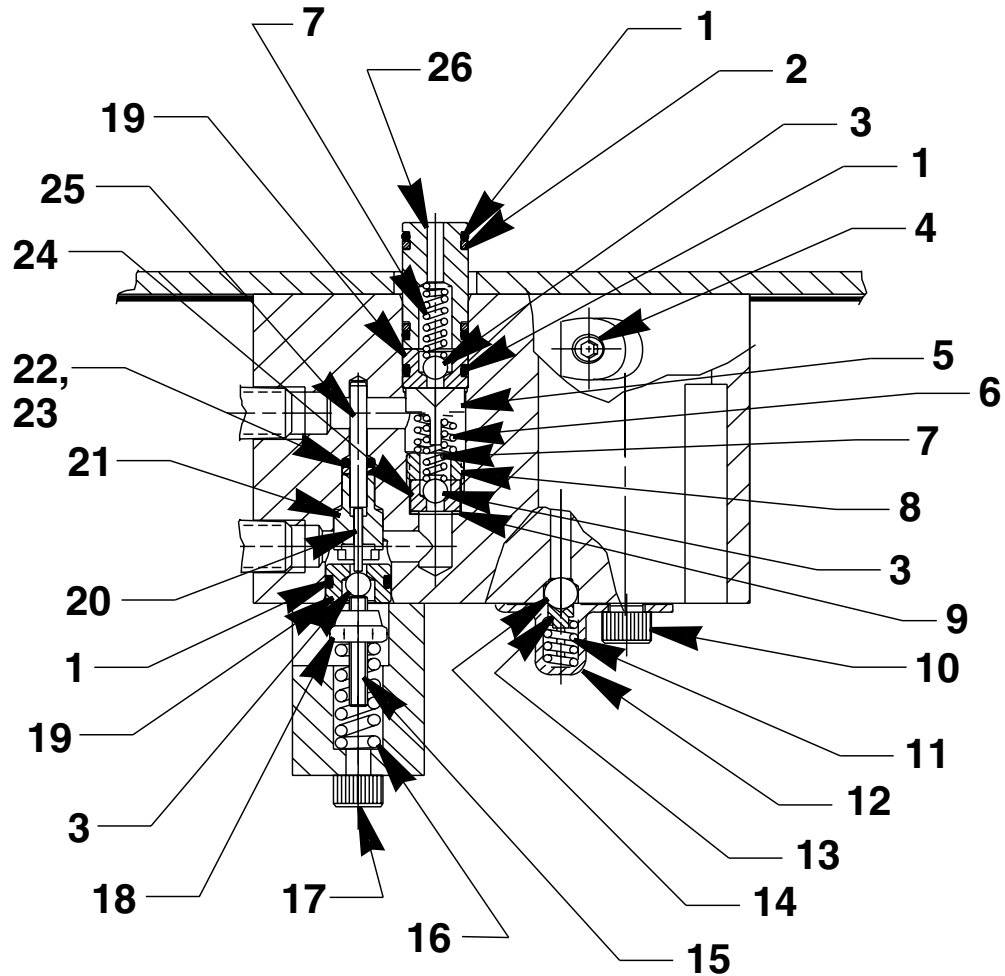

Item No.	Part No.	No. Req'd	Description	Item No.	Part No.	No. Req'd	Description
1	10268	4	O-ring (1/2 X 3/8 X 1/16)	13	200796	1	Adapter
2	11863	2	Backup Washer (1/2 X 3/8 X 1/16)	14	10374	1	Steel Ball (7/32 Dia.)
3	12223	3	Ball (3/16 Dia.)	15	251067	1	Set Screw (Unloading valve; #10-24 UNC x 1" Lg.)
4	15130	1	Plug (1/16 NPTF)	16	14484	1	Compression Spring (3/8 O.D. X 1" Lg.)
5	251601	1	Outlet Ball Stop	17	10854	2	Cap Screw (1/4-20 UNC X 1-3/4" Lg.; Torque to 60/80 in. lbs.)
6	10444	1	Compression Spring (3/16 I.D. X 13/32 Lg.)	18	207405	1	Locknut (10-24 UNC)
7	10445	2	Compression Spring (5/32 O.D. X 3/4 Lg.)	19	251065	2	Replaceable Seat
8	209797	1	Hollow Lock Screw (7/16-20 UNF-3A; Torque to 110/130 in. lbs.)	20	251611	1	Dowel Pin (5/8 X 1/2 Lg.)
9	10442	1	Washer (3/8 X 1/4 X 1/32)	21	251068	1	Guide
10	10002	1	Cap Screw (1/4-20 UNC X 3/8 Lg.; Torque to 60/80 in. lbs.)	22	17797	1	O-ring (1/4 X 1/8 X 1/16)
11	15691	1	Compression Spring (1/4 O.D. X 5/8 Lg.)	23	214992	1	Backup Ring (15/64 x 1/8 x 3/64)
12	350577	1	Spring Retainer	24	209787	1	Replaceable Seat
				25	16471	1	Dowel Pin (1/8 dia. x 1" Lg.; Taper on pin should be away from guide [Item #21].)
				26	251581	1	Bushing

TOP VIEW

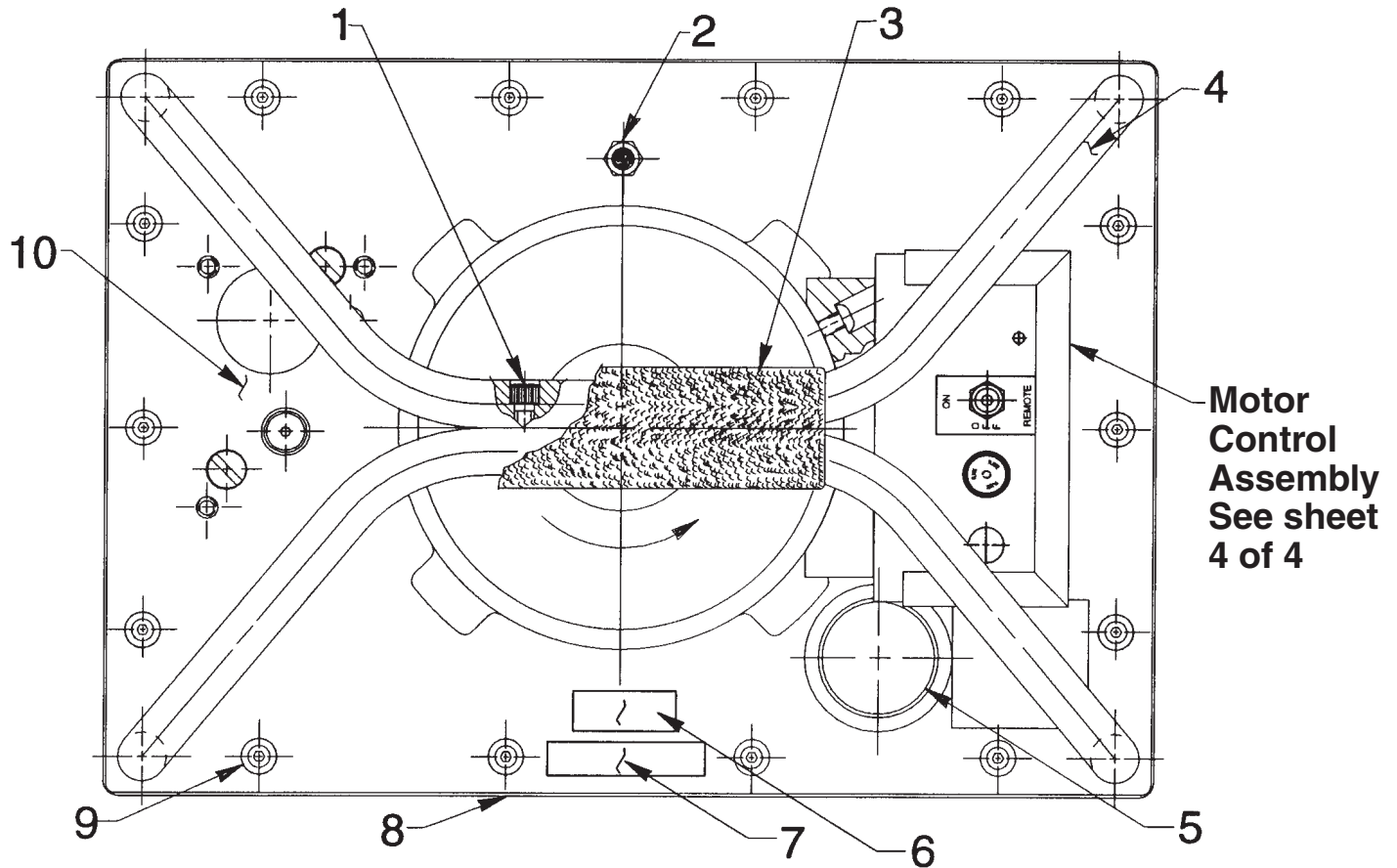

Item No.	Part No.	No. Req'd	Description
1	10008	2	Cap Screw (For PE302R-2-220, PE303R-2-220 & PE304R-2-220 only)
2	251599	1	Breather Filter Vent
3	251600	1	Handle Grip (For PE302R-2-220, PE303R-2-220 & PE304R-2-220 only)
4	64677BK2	1	Handle (For PE302R-220, PE303R-220, & PE304R-220)
	64582BK2	1	Roll Cage Frame (For PE302R-2-220, PE303R-2-220 & PE304R-2-220)
5	350925	1	Filler Cap
6	203972	1	Logo CSA Decal
7	213695	1	Intermittent Duty Decal
8	309219	2	Trade Name Decal (For PE302R-220, PE303R-220, & PE304R-220)
	309221	2	Trade Name Decal (For PE302R-2-220, PE303R-2-220 & PE304R-2-220)
9	10177	14	Cap Screw (1/4-20 X 5/8 Lg.; Torque to 70 in. lbs. Note: On models with a one gallon reservoir, four of these mount the handle also [see back sheet 1 of 4].)
10	9584	1	Valve Assembly (For PE302R-220 & PE302R-2-220; See Form No. 101239) Note: When ordering this valve also order (4) 10890 Cap Screws for mounting valve to pump.
	9520	1	Valve Assembly (For PE303R-220 & PE303R-2-220; Apply Loctite #242 to threads of valve handle stem [both ends.] See Form No. 101377) Note: When ordering this valve also order (4) 11956 Cap Screws for mounting valve to pump.
	52516	1	Valve Assembly (For PE304R-220 & PE304R-2-220; Apply Loctite #242 to threads of valve handle stem [both ends.] See Form No. 100623) Note: When ordering this valve also order (4) 11956 Cap Screws for mounting valve to pump.

BOTTOM VIEW AND SECTION A-A

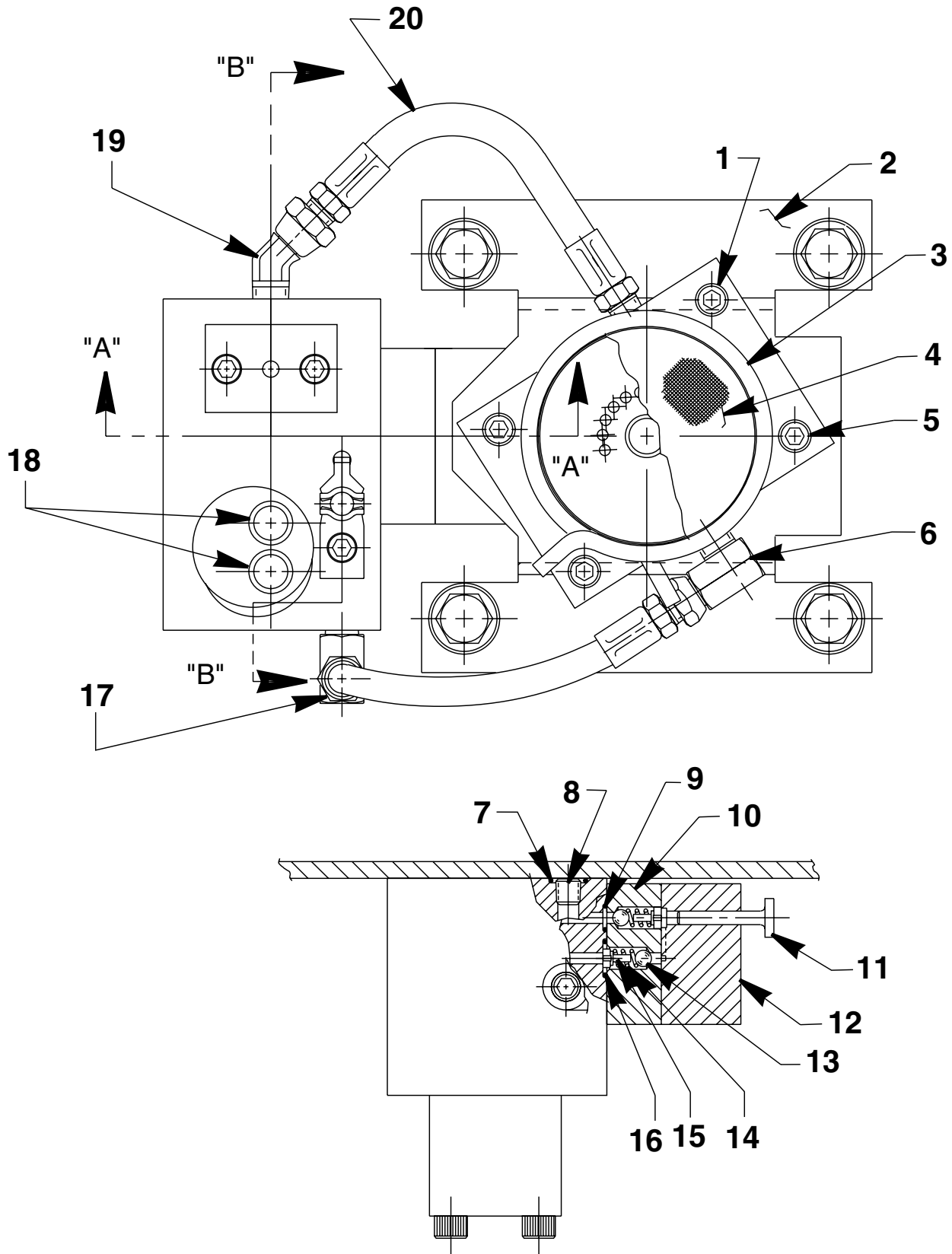

Item No.	Part No.	No. Req'd	Description
1	10022	2	Cap Screw (1/4-20 UNC X 1-1/2" Lg.; Torque to 60/80 in. lbs.)
2	58481	1	Gerotor Housing Bracket
3	11461	1	Hose Clamp
4	21608	1	Filter
5	10890	2	Cap Screw (1/4-20 UNC X 2" Lg.; Torque to 60/80 in. lbs.)
6	14440	1	90° Elbow Fitting
7	15279	1	O-ring (1/2 X 3/8 X 1/16)
8	15130	1	Plug (1/16 NPTF)
9	10265	1	O-ring (5/16 X 3/16 X 1/16)
10	45559	1	Block
11	305526	1	High Pressure Piston
12	45866	1	Block

Item No.	Part No.	No. Req'd	Description
13	12223	2	Ball (3/16 Dia.)
14	10445	2	Compression Spring (5/32 O.D. X 3/4 Lg.)
15	24549	2	Ball Guide
16	14763	1	O-ring (7/16 X 5/16 X 1/16)
17	13229	1	Elbow
18	250630	2	Drain Tube (For PE303R-220 & PE303R-2-220)
	250630	1	Drain Tube (For PE302R-220, PE302R-2-220, PE304R-220 & PE304R-2-220)
19	251800	1	Elbow Fitting
20	304819	2	Hose Assembly

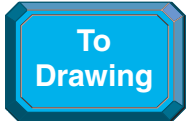

HYDRAULIC SCHEMATIC

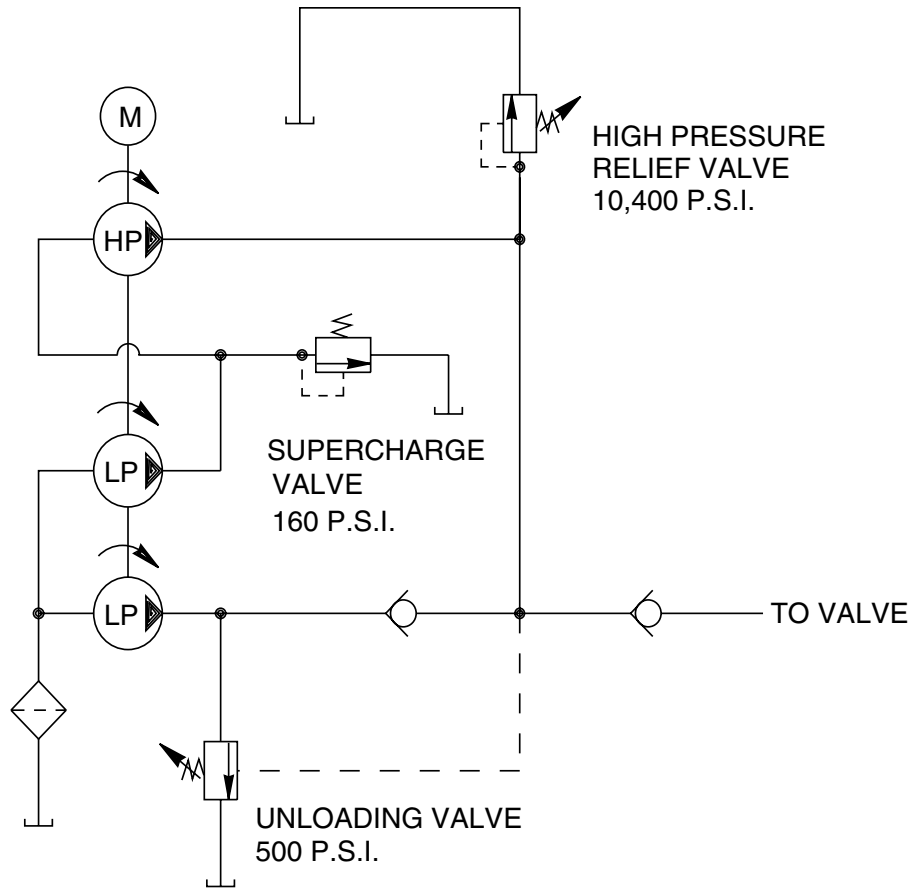

MOTOR & CONTROL ASSEMBLY

220/230 V., 50/60 Hz.

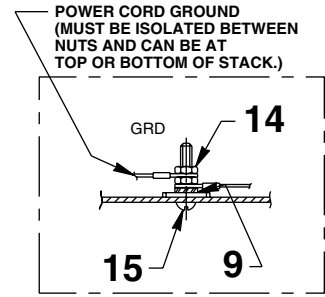
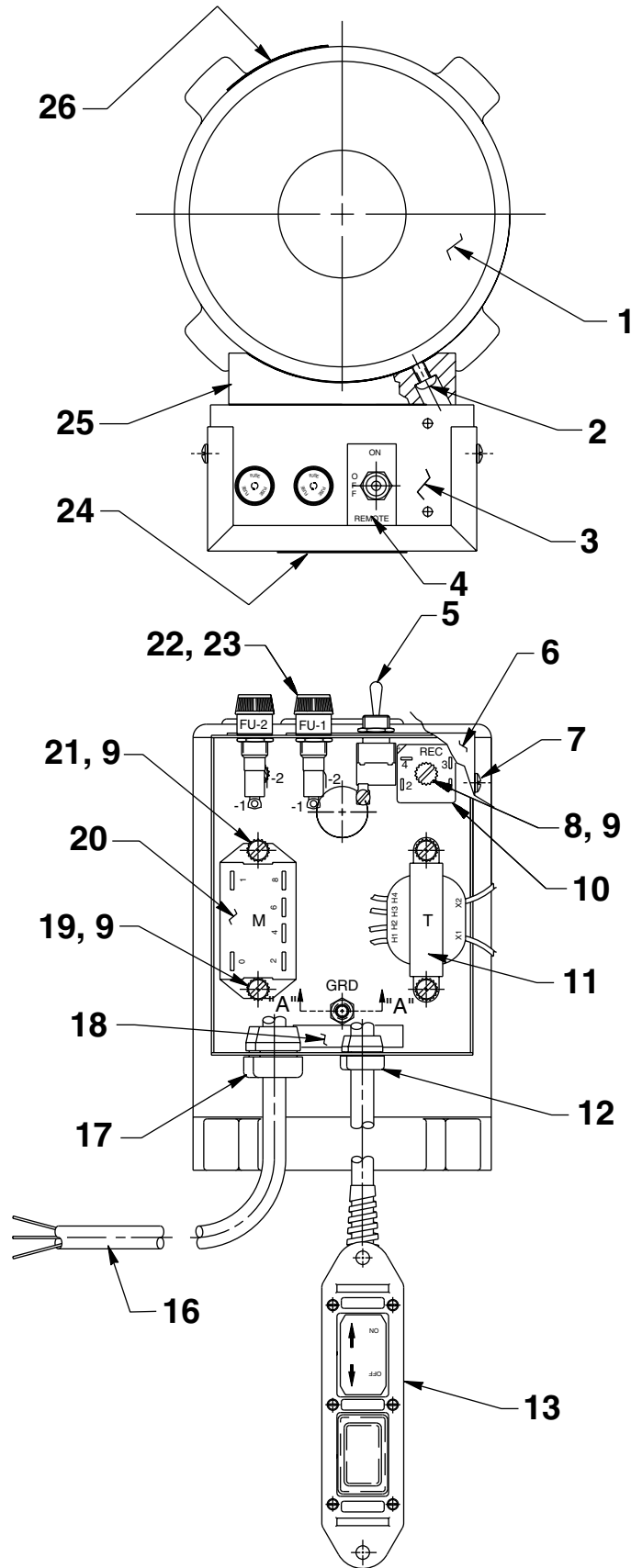

POWER CORD GROUND
(MUST BE ISOLATED BETWEEN
NUTS AND CAN BE AT
TOP OR BOTTOM OF STACK.)

NOTE: SERRATED LOCK WASHER
MUST BE ADJACENT TO
METAL BOX. MORE WASHERS
CAN BE USED IF DESIRED.

VIEW "A-A"

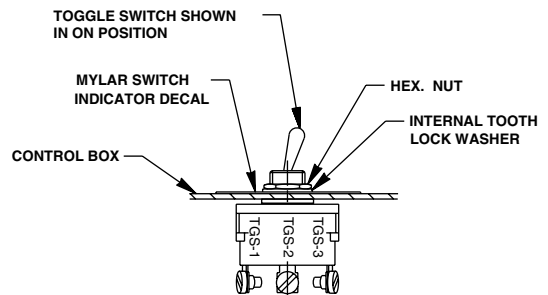

Parts List, Form No. 101859, Back sheet 4 of 4

Item No.	Part No.	No. Req'd	Description	Item No.	Part No.	No. Req'd	Description
1	*420839BK2	1	Motor, Elec. (230V, 60HZ)	14	10197	2	Nut, Hex (10-24)
2	12316	2	Screw, Pan Head (10-24 x 5/8)	15	11856	1	Screw, Round Hd (10-24 x 1)
3	59025BK2	1	Box, Electrical Control	16	308752	9 ft.	Cable (14/3 SJTO)
4	25802	1	Decal, Switch Indicator	17	210112	1	Bushing, Strain Relief
5	12665	1	Switch, Toggle	18	205189	1	Decal, Label Ground
6	42576BK2	1	Cover, Control Box	19	10164	2	Screw, Round Hd (10-24 x 3/8)
7	11141	4	Screw, Pan Head (6-20 x 3/8)	20	251638	1	Relay, General Purpose
8	252872	1	Screw, Round Hd (10-32 x 5/8)	21	12909	3	Screw, Round Hd (10-32 x 1/4)
9	11108	7	Washer, Tooth Ext. (.40 x .20)	22	18292	2	Holder, Fuse
10	251050	1	Rectifier	23	252873	2	Fuse (10 AMP, 250V)
11	251049	1	Transformer	24	200188	1	Decal, Warning Important
12	15993	1	Bushing, Strain Relief	25	420962	1	Adapter, Mounting
13	25017	1	Control, Hand (See Form No. 101644)	26	351024	1	Decal, Vanguard 30 Series

* Note: For replacement brushes, order (2) #252961.



ELECTRICAL SCHEMATIC 220/230 V., 50/60 Hz.



WARNING: To help avoid personal injury, all electrical work must be done by a qualified electrician.

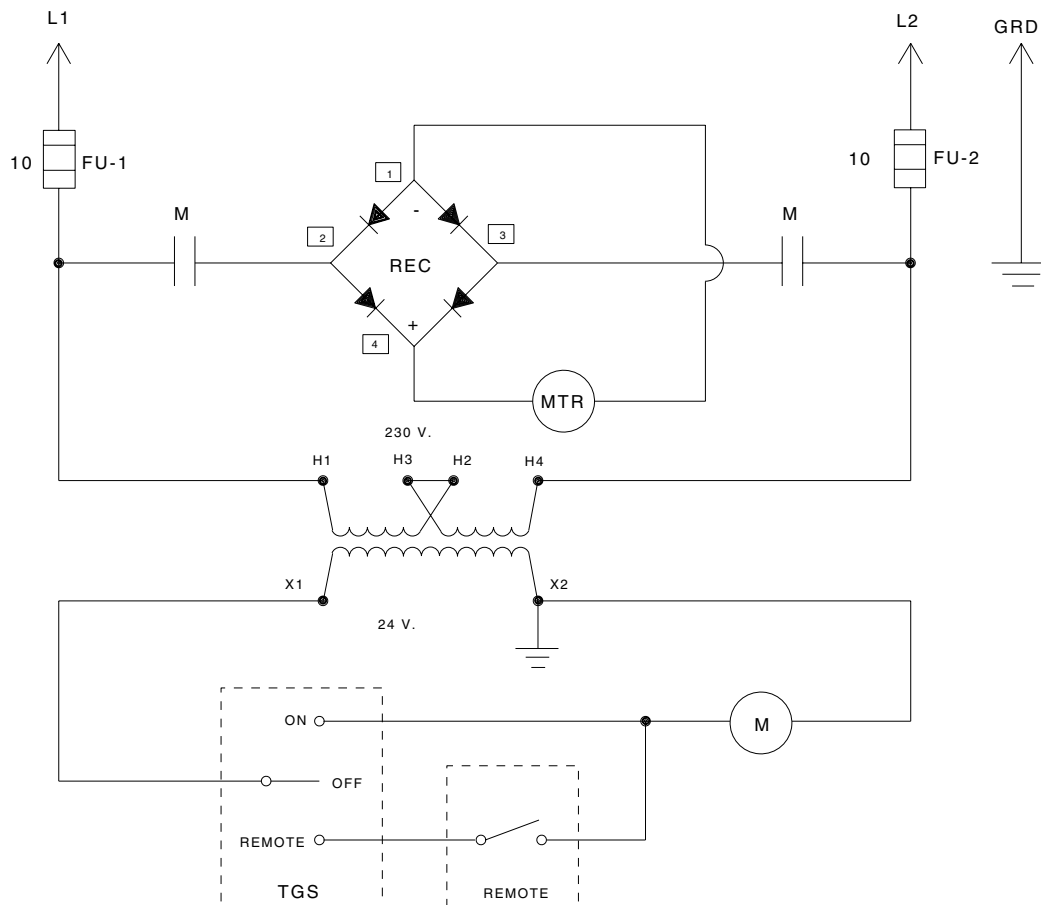

Note: Shaded areas reflect last revision(s) made to this form.