

Parts List for:

PE302S
PE302S-2
PE302S-220

PE302S-2-220
PE302S-CODHE
PE302S-GRAB
PE302S-HENN

MODEL B
ELECTRIC HYDRAULIC PUMP
Max. Capacity: 10,000 PSI



This view illustrates models with a 1-3/4 gallon reservoir.

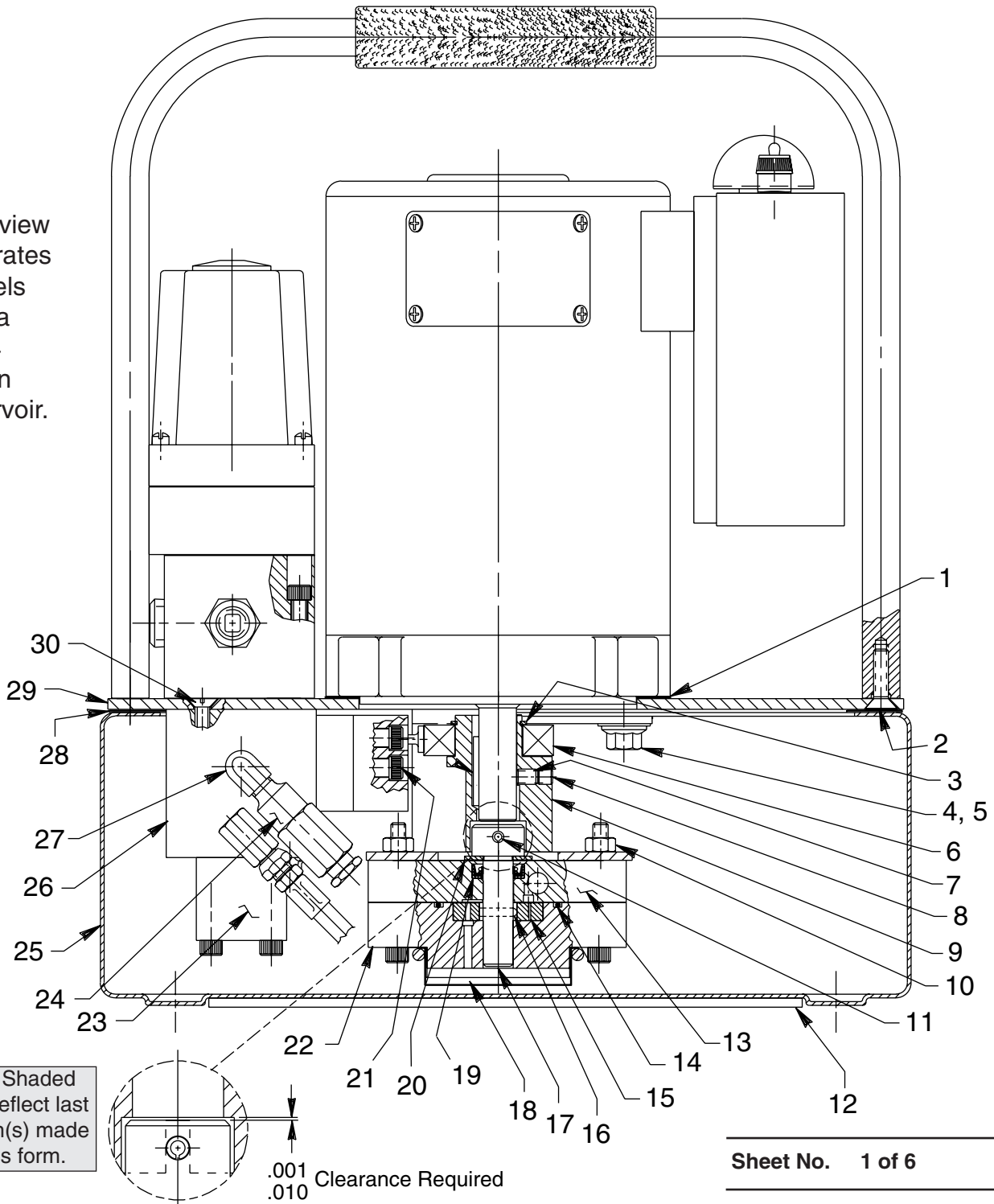

Note: Shaded areas reflect last revision(s) made to this form.

.001
.010 Clearance Required

Sheet No. 1 of 6

Rev. 5

Date: 26 Feb. 2001

Parts List, Form No. 101860, Back sheet 1 of 6

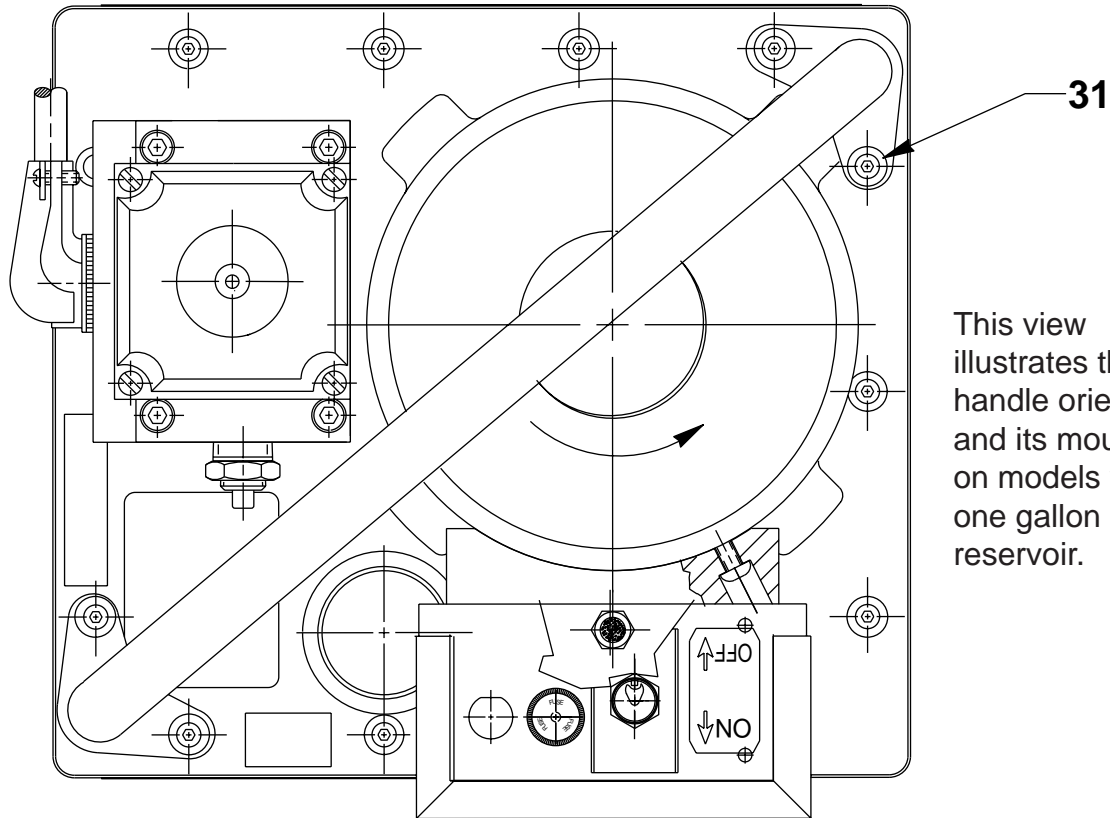

This view illustrates the handle orientation, and its mounting, on models with a one gallon reservoir.

Item No.	Part No.	No. Req'd	Description	Item No.	Part No.	No. Req'd	Description
1	351060	1	Motor Base Gasket	23	350930	1	Retaining Block
2	11529	4	Cap Screw (1/4-20 UNC x 3/4 Lg.; Apply Loctite No. 242 or equiv. For PE302S-2, & PE302S-2-220)	24	21278	1	Relief Valve Assembly (Set at 10,100/10,700 PSI; For all models except PE302S-HENN)
3	209798	1	Retaining Ring		21278-50	1	Relief Valve Assembly (Set at 5,100/5,700 PSI; FOR PE302S-HENN)
4	213663	4	Cap Screw (3/8-16 UNC X 1" Lg.; Torque to 230/250 in. lbs.)		21278-72	1	Relief Valve Assembly (Set at 7,350/7,950 PSI; For PE302S-CODHE)
5	10258	4	Washer (For 3/8 bolt)	25	64665OR9	1	Reservoir (1 Gal. - For PE302S, PE302S-220, PE302S-CODHE, PE302S-HENN & PE302S-GRAB)
6	209805	1	Ball Bearing		64241OR9	1	Reservoir (2 Gal. - For PE302S-2 & PE302S-2-220)
7	10136	1	Set Screw (1/4-20 UNC x 1/4 Lg.; Torque to 60/80 in. lbs.)	26	64612	1	Check Body
8	10519	1	Set Screw (1/4-20 UNC X 3/8 Lg.; Torque to 60/80 in. lbs.)	27	13229	1	Street Elbow
9	420840	1	Eccentric	28	420931	1	Reservoir Gasket (1 Gal. - For PE302S, PE302S-220, PE302S- CODHE, PE302S-HENN & PE302S-GRAB)
10	10199	2	Hex Nut (1/4-20 UNC)		420424	1	Reservoir Gasket (2 Gal. - For PE302S-2 & PE302S-2-220)
11	12298	1	Roll Pin (3/16 dia. x 1-1/2" Lg.)	29	64666BK2	1	Cover Plate (For PE302S, PE302S-220, PE302S-CODHE, PE302S-HENN & PE302S-GRAB)
12	420427	1	Rubber Pad (For PE302S-2 & PE302S-2-220)		64579BK2	1	Cover Plate (For PE302S-2 & PE302S-2-220)
	420948	1	Rubber Pad (For PE302S, PE302S-220, PE302S-CODHE, PE302S-HENN & PE302S-GRAB)	30	11529	2	Screw (1/4-20 UNC x 3/4 Lg.)
13	64623	1	Upper Gerotor Housing	31	10177	4	Cap Screw (1/4-20 5/8 Lg.; Apply Loctite No. 242 or equiv. and torque to 60/80 in. lbs.; For PE302S, PE302S-220, PE302S-HENN & PE302S-GRAB)
14	10922	1	O-ring (2-1/8" X 1-15/16" X 3/32)				
15	304826	1	Gerotor				
16	209794	1	Gerotor Drive Pin				
17	350940	1	Gerotor Shaft				
18	21846	1	Filter Support				
19	304830	1	Oil Seal				
20	12595	1	Washer (1-1/8" X 1/2" X .077 Thk.)				
21	10022	4	Screw (1/4-20 UNC X 1-1/2" Lg.; Torque to 180/200 in. lbs.)				
22	64580	1	Gerotor Housing				



HIGH PRESSURE PUMP ASSEMBLY

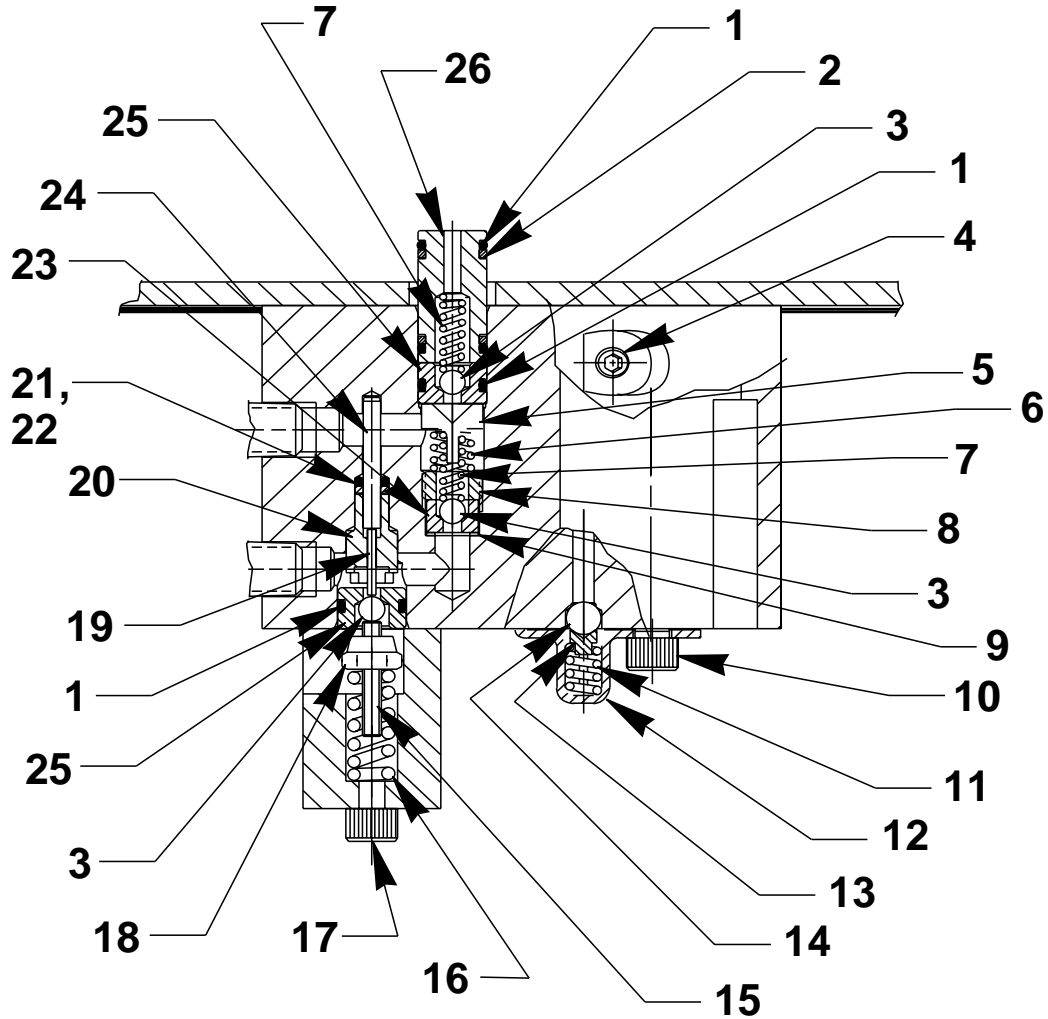

Item No.	Part No.	No. Req'd	Description
1	10268	4	O-ring (1/2 X 3/8 X 1/16)
2	11863	2	Backup Washer (1/2 X 3/8 X 1/16)
3	12223	3	Ball (3/16 Dia.)
4	15130	1	Plug (1/16 NPTF)
5	251601	1	Outlet Ball Stop
6	10444	1	Compression Spring (3/16 I.D. X 13/32 Lg.)
7	10445	2	Compression Spring (5/32 O.D. X 3/4 Lg.)
8	209797	1	Hollow Lock Screw (7/16-20 UNF-3A; Torque to 110/130 in. lbs.)
9	10442	1	Washer (3/8 X 1/4 X 1/32)
10	10002	1	Cap Screw (1/4-20 UNC X 3/8 Lg.; Torque to 60/80 in. lbs.)
11	15691	1	Compression Spring (1/4 O.D. X 5/8 Lg.)
12	350577	1	Spring Retainer
13	200796	1	Adapter

Item No.	Part No.	No. Req'd	Description
14	10374	1	Steel Ball (7/32 Dia.)
15	251067	1	Set Screw (Unloading valve; #10-24 UNC x 1" Lg.)
16	14484	1	Compression Spring (3/8 O.D. X 1" Lg.)
17	10854	2	Cap Screw (1/4-20 UNC X 1-3/4" Lg.; Torque to 60/80 in. lbs.)
18	207405	1	Locknut (10-24 UNC)
19	251611	1	Dowel Pin (1/2 x 3/8 x .049)
20	251068	1	Guide
21	17797	1	O-ring (1/4 X 1/8 X 1/16)
22	214992	1	Backup Ring (15/64 x 1/8 x 3/64)
23	209787	1	Replaceable Seat
24	16471	1	Dowel Pin (1/8 dia. x 1" Lg.; Taper on pin should be away from guide [Item #20].)
25	251065	2	Replaceable Seat
26	251581	1	Bushing

TOP VIEW

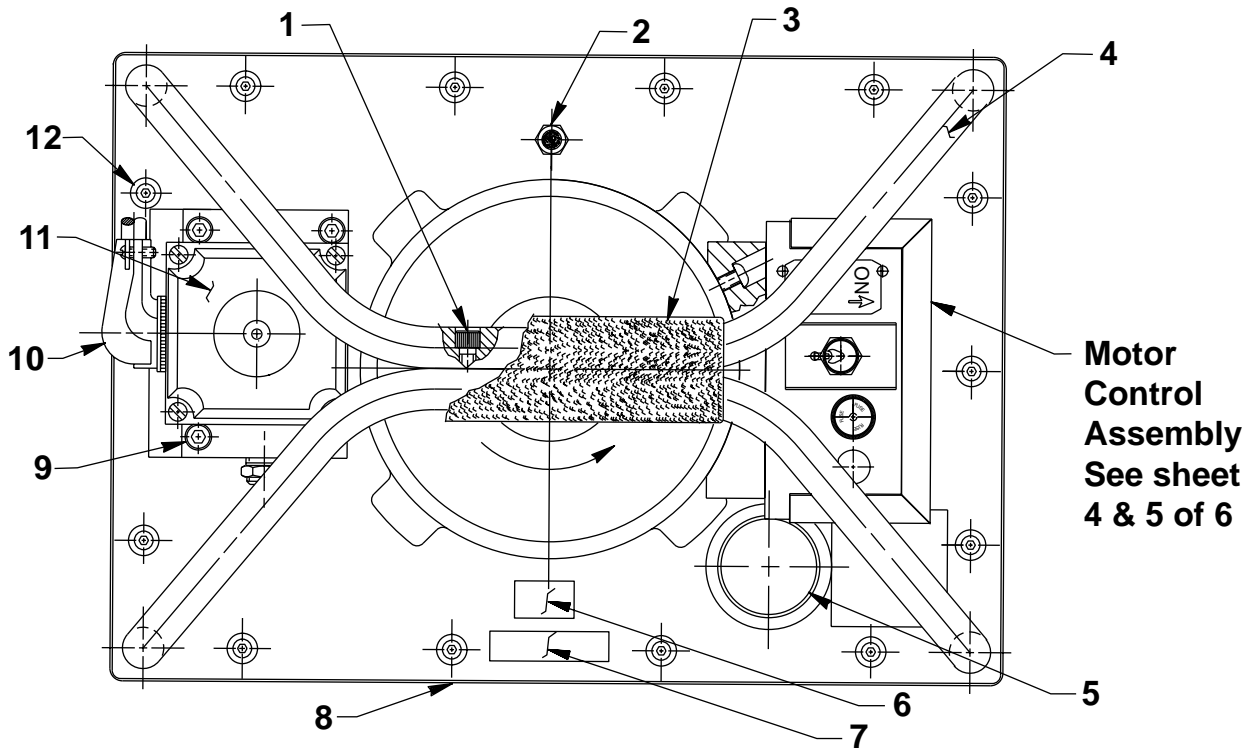

Item No.	Part No.	No. Req'd	Description
1	10008	2	Cap Screw (For PE302S-220 & PE302S-2-220 only)
2	251599	1	Breather Filter Vent
3	251600	1	Handle Grip (For PE302S-220 & PE302S-2-220 only)
4	64677BK2	1	Handle (For PE302S, PE302S-220, PE302S-CODHE, PE302S-HENN & PE302S-GRAB)
	64582BK2	1	Roll Cage Frame (For PE302S-2 & PE302S-2-220)
5	350925	1	Filler Cap
6	203972	1	Logo CSA Decal (For PE302S & PE302S-220 only)
7	213695	1	Intermittent Duty Decal
8	309219	2	Trade Name Decal (For PE302S, PE302S-220, PE302S-CODHE, PE302S-HENN & PE302S-GRAB)
	309221	2	Trade Name Decal (For PE302S-2 & PE302S-2-220)
9	10856	4	Cap Screw
10	11144	1	90° Connector
11	42621	1	Solenoid Valve Assembly (For PE302S, PE302S-2, PE302S-HENN & PE302S-GRAB; See Form No. 100445)
	44084	1	Solenoid Valve Assembly (For PE302S-220, PE302S-CODHE & PE302S-2-220; See Form No. 100445)
12	10177	14	Cap Screw (1/4-20 X 3/4 Lg.; Torque to 60/80 in. lbs. Note: On models with a one gallon reservoir, four of these mount the handle also [see back sheet 1 of 6].)

Refer to any operating instructions included with this product for detailed information about operation, testing, disassembly, reassembly, and preventive maintenance.

Items found in this parts list have been carefully tested and selected. **Therefore: Use only genuine Power Team replacement parts!**

Additional questions can be directed to our Technical Services Department.

BOTTOM VIEW AND SECTION A-A

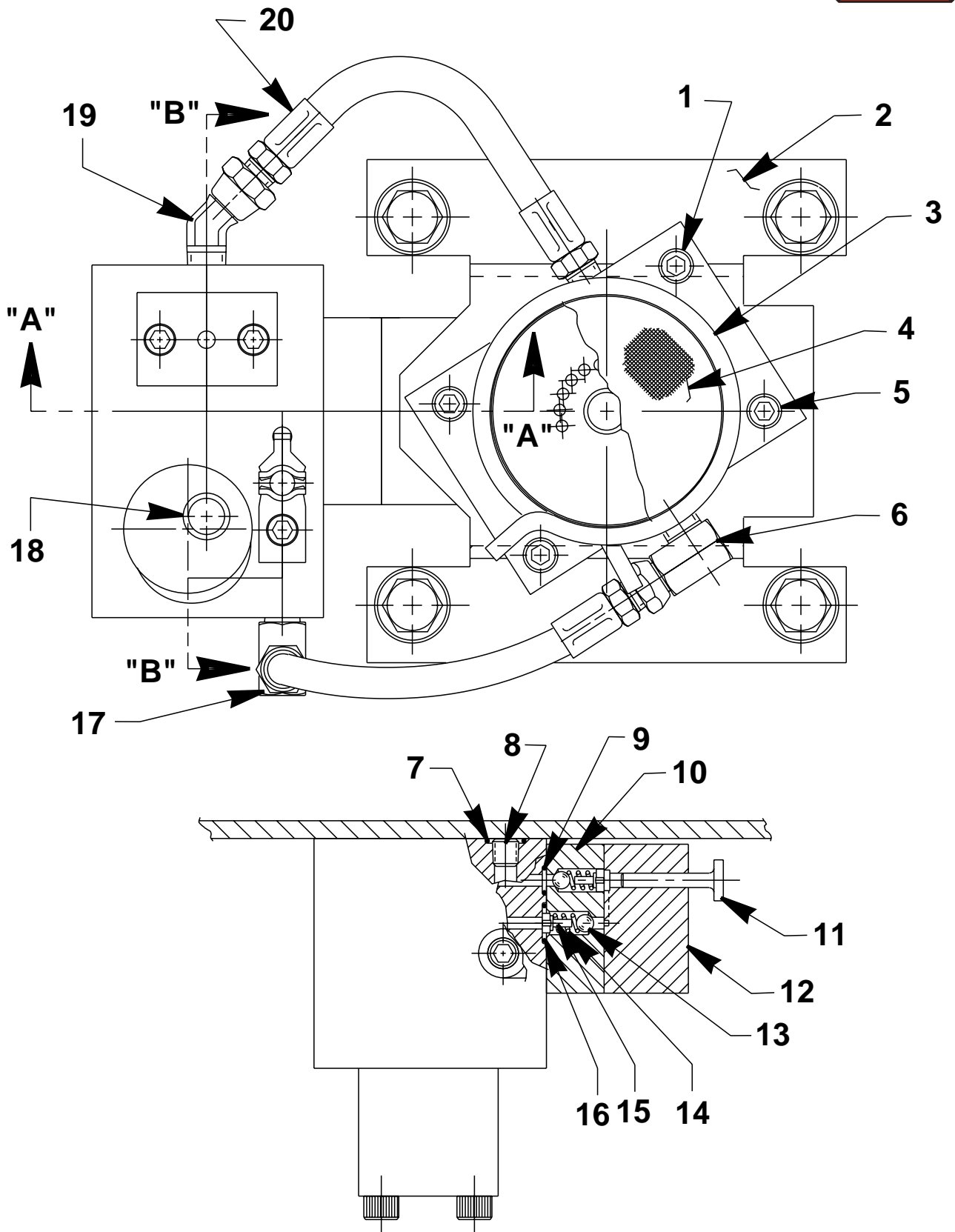

Item No.	Part No.	No. Req'd	Description
1	10022	2	Cap Screw (1/4-20 UNC X 1-1/2" Lg.; Torque to 60/80 in. lbs.)
2	58481	1	Gerotor Housing Bracket
3	11461	1	Hose Clamp
4	21608	1	Filter
5	10890	2	Cap Screw (1/4-20 X 2" Lg.; Torque to 60/80 in. lbs.)
6	14440	1	90° Elbow Fitting
7	15279	1	O-ring (1/2 X 3/8 X 1/16)
8	15130	1	Plug (1/16 NPTF)
9	10265	1	O-ring (5/16 X 3/16 X 1/16)
10	45559	1	Block
11	305526	1	High Pressure Piston
12	45866	1	Block
13	12223	2	Ball (3/16 Dia.)
14	10445	2	Compression Spring (5/32 O.D. X 3/4 Lg.)
15	24549	2	Ball Guide
16	14763	1	O-ring (7/16 X 5/16 X 1/16)
17	13229	1	Elbow
18	250630	1	Drain Tube
19	251800	1	Elbow Fitting
20	304819	2	Hose Assembly



HYDRAULIC SCHEMATIC

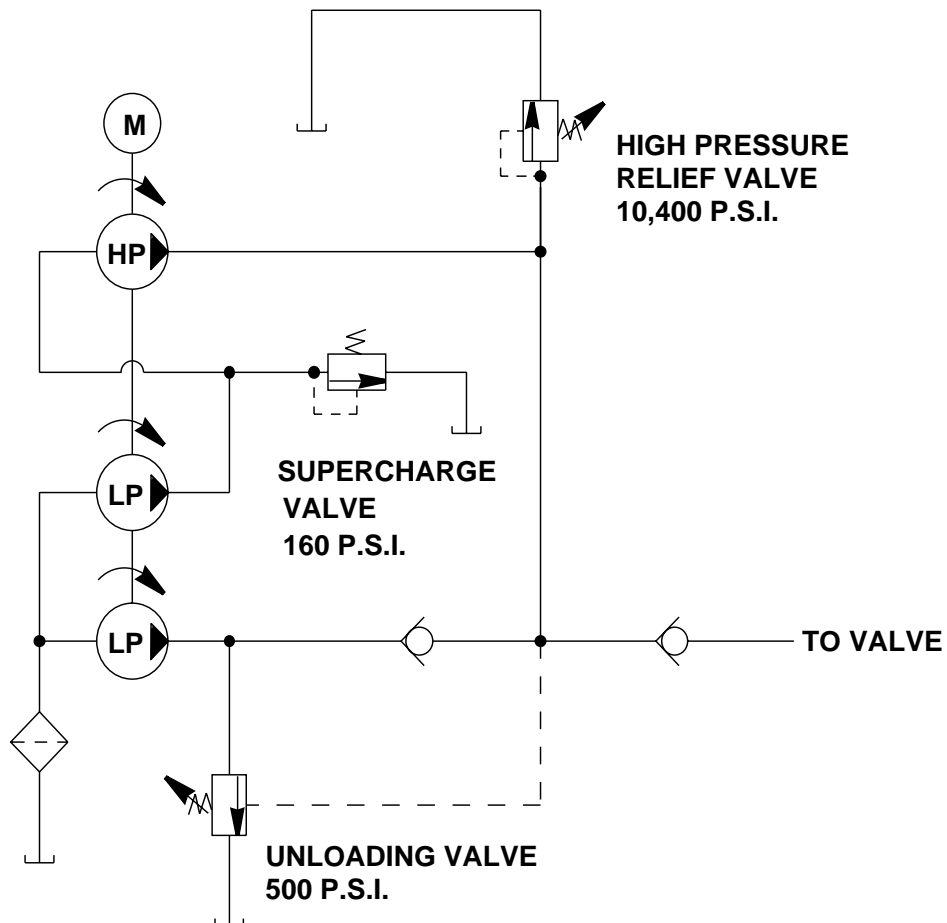

MOTOR & CONTROL ASSEMBLY

110/115 Volt

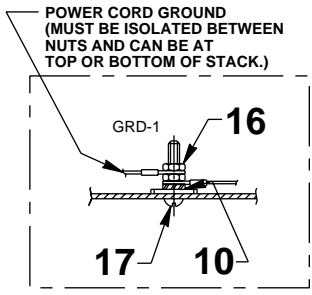
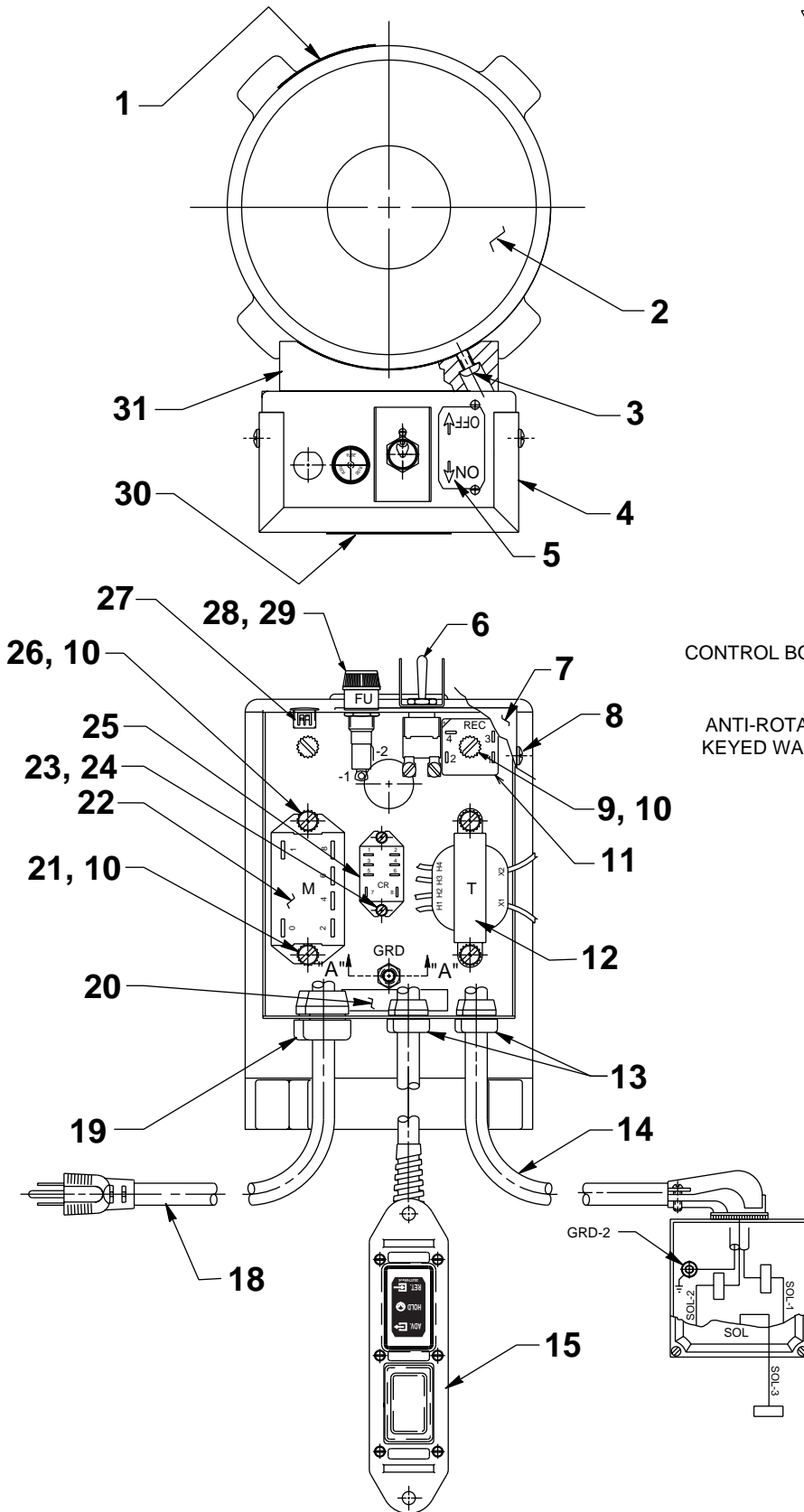

POWER CORD GROUND
(MUST BE ISOLATED BETWEEN
NUTS AND CAN BE AT
TOP OR BOTTOM OF STACK.)

NOTE: SERRATED LOCK WASHER
MUST BE ADJACENT TO
METAL BOX. MORE WASHERS
CAN BE USED IF DESIRED.

VIEW "A-A"

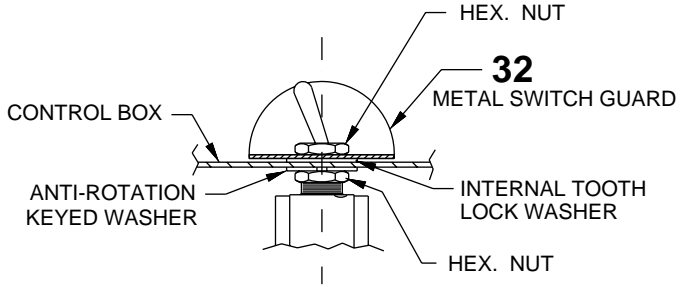

SWITCH DETAIL

Parts List, Form No. 101860, Back sheet 4 of 6

Item No.	Part No.	No. Req'd	Description	Item No.	Part No.	No. Req'd	Description
1	351024	1	Decal, Vanguard 30 Series	17	11856	1	Screw, Round Hd (10-24 x 1)
2	*420838BK2	1	Motor, Elec. (115 V., 60 HZ.)	18	25229	1	Cord (8' Lg, 115V, 14/3 SJTO)
3	12316	2	Screw, Pan Head (10-24 x 5/8)	19	210112	1	Bushing, Strain Relief
4	59025BK2	1	Box, Electrical Control	20	205189	1	Decal, Label Ground
5	205409	1	On/Off Label Decal	21	10164	2	Screw, Round Hd (10-24 x 3/8)
6	12301	1	Switch, Toggle	22	251638	1	Relay, General Purpose
7	42576BK2	1	Cover, Control Box	23	10159	2	Screw, Round Hd (6-32 x 5/16)
8	11141	4	Screw, Pan Head (6-20 X 3/8)	24	15906	2	Washer, Tooth Ext (.31 x .15)
9	252872	1	Screw, Round Hd (10-32 x 5/8)	25	251046	1	Relay, General Purpose
10	11108	7	Washer, Tooth Ext (.40 x .20)	26	12909	3	Screw, Round Hd (10-32 x 1/4)
11	251050	1	Rectifier	27	17782	1	Plug, Snap
12	251049	1	Transformer	28	18292	1	Holder, Fuse
13	15993	2	Bushing, Strain Relief	29	252288	1	Fuse (15 AMP, 250V)
14	12293	2.5 ft.	Cable (16/3 SJTO)	30	200188	1	Decal, Warning Important
15	202778	1	Control, Remote Hand (See Form No. 101644)	31	420962	1	Adapter Mounting
16	10197	2	Nut, Hex (10-24)	32	352061	1	Metal Switch Guard

* Note: For replacement brushes, order (2) #252958.



ELECTRICAL SCHEMATIC 110/115 Volt



WARNING: To help avoid personal injury, all electrical work must be done by a qualified electrician.

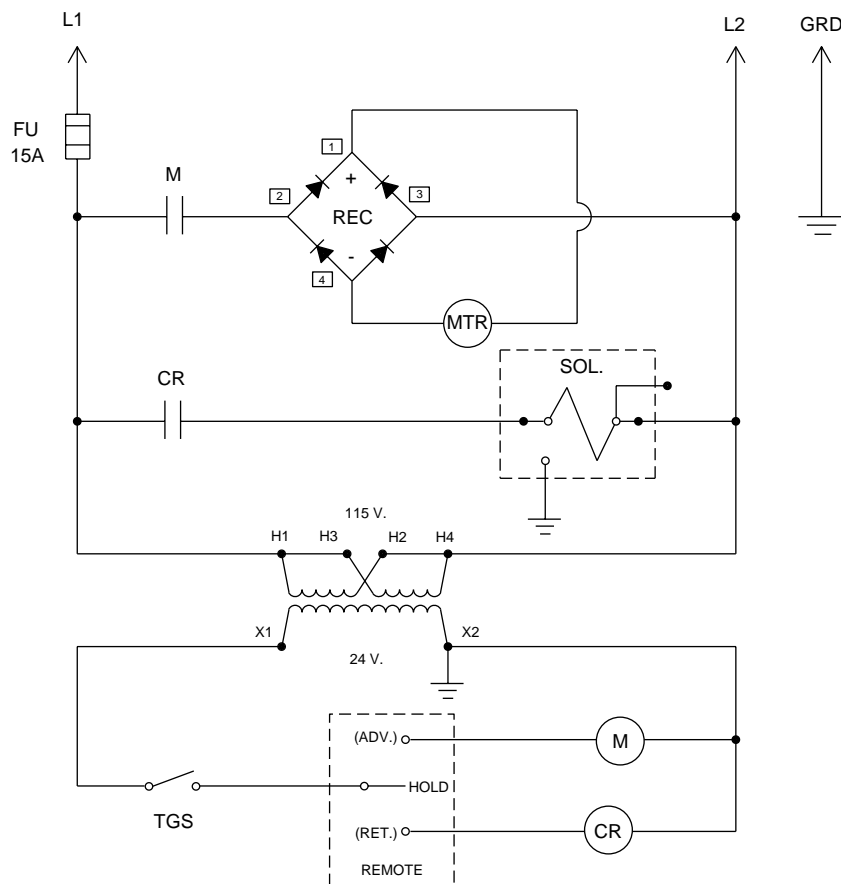

Note: Shaded areas reflect last revision(s) made to this form.

MOTOR & CONTROL ASSEMBLY

220/230 Volt

To Parts List

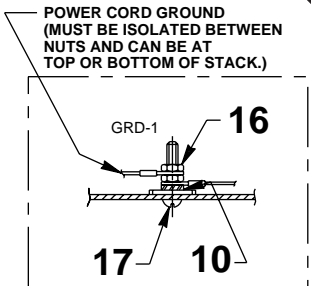
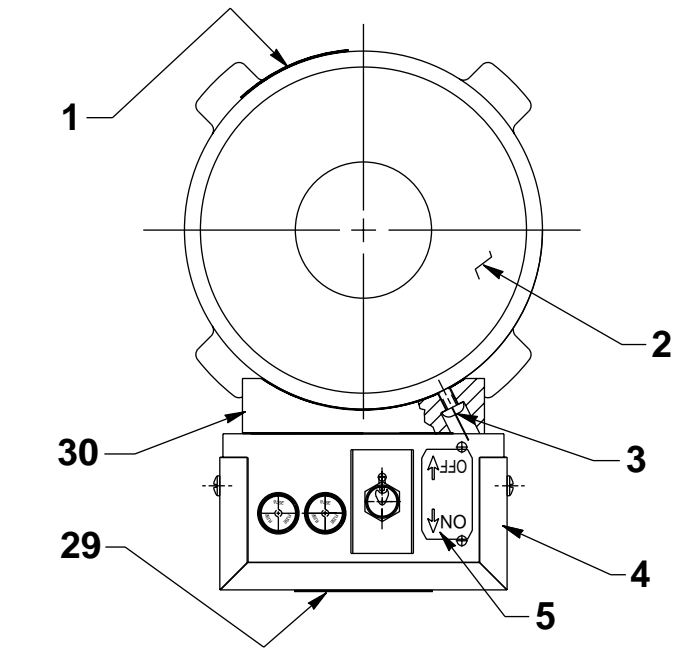

NOTE: SERRATED LOCK WASHER MUST BE ADJACENT TO METAL BOX. MORE WASHERS CAN BE USED IF DESIRED.

VIEW "A-A"

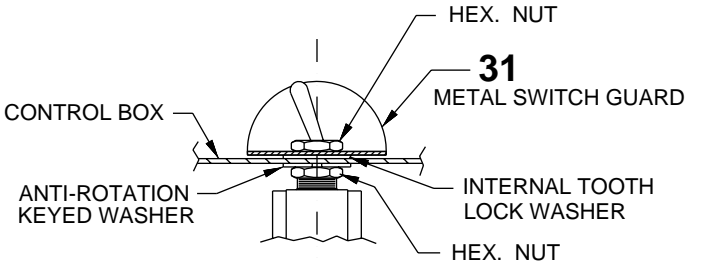
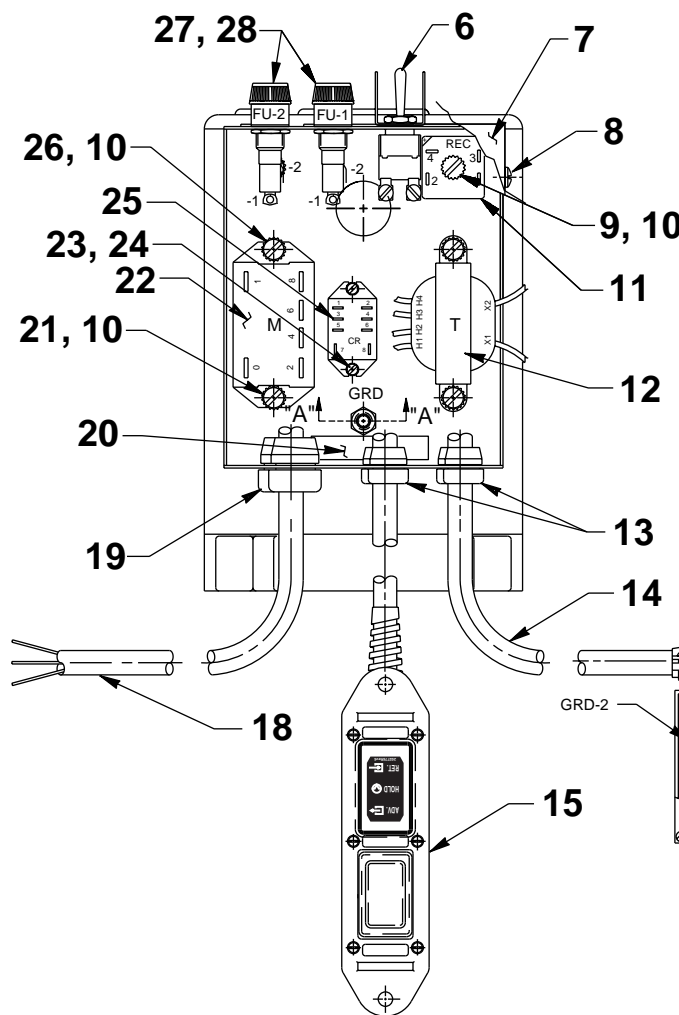

SWITCH DETAIL

Item No.	Part No.	No. Req'd	Description	Item No.	Part No.	No. Req'd	Description
1	351024	1	Decal, Vanguard 30 Series	16	10197	2	Nut, Hex (10-24)
2	*420839BK2	1	Motor, Elec. (230 V., 60 HZ)	17	11856	1	Screw, Round Hd (10-24 x 1)
3	12316	2	Screw, Pan Head (10-24 x 5/8)	18	308752	1	Cable (14/3 SJTO)
4	59025BK2	1	Box, Electrical Control	19	210112	1	Bushing, Strain Relief
5	205409	1	On/Off Label Decal	20	205189	1	Decal, Label Ground
6	12301	1	Switch, Toggle	21	10164	2	Screw, Round Hd (10-24 x 3/8)
7	42576BK2	1	Cover, Control Box	22	251638	1	Relay, General Purpose
8	11141	4	Screw, Pan Head (6-20 X 3/8)	23	10159	2	Screw, Round Hd (6-32 x 5/16)
9	252872	1	Screw, Round Hd (10-32 x 5/8)	24	15906	2	Washer, Tooth Ext (.31 x .15)
10	11108	7	Washer, Tooth Ext (.40 x .20)	25	251046	1	Relay, General Purpose
11	251050	1	Rectifier	26	12909	3	Screw, Round Hd (10-32 x 1/4)
12	251049	1	Transformer	27	18292	2	Holder, Fuse
13	15993	2	Bushing, Strain Relief	28	252873	2	Fuse (10 AMP, 250V)
14	12293	2.5 ft.	Cable (16/3 SJTO)	29	200188	1	Decal, Warning Important
15	307491	1	Control, Hand (See sheet 6 of 6)	30	420962	1	Adapter Mounting
				31	352061	1	Metal Switch Guard

* Note: For replacement brushes, order (2) #252961.



ELECTRICAL SCHEMATIC 220/230 Volt



WARNING: To help avoid personal injury, all electrical work must be done by a qualified electrician.

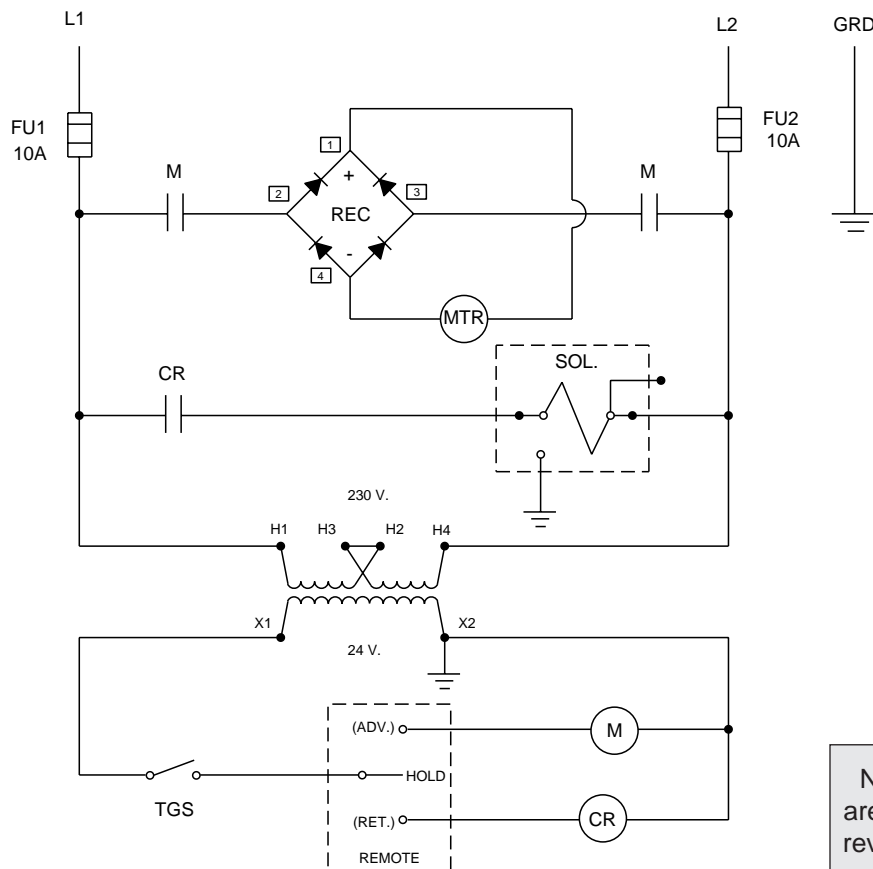

Note: Shaded areas reflect last revision(s) made to this form.

REMOTE HAND SWITCH ASSEMBLY

No. 307491

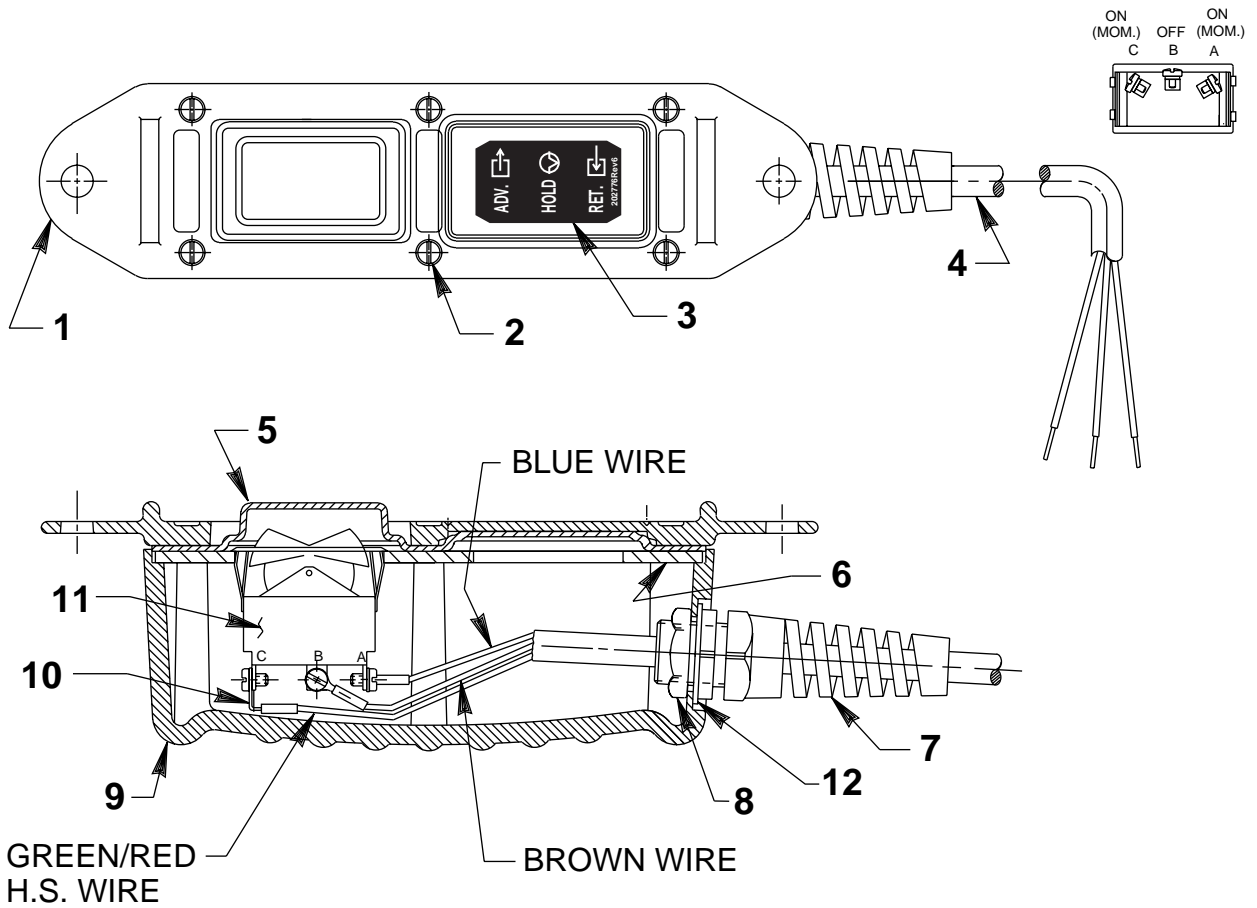

Item No.	Part No.	No. Req'd	Description
1	420050-1	1	Cover
2	250248	6	Screw (4-24 x 3/4 Lg.)
3	202776	1	Decal
4	12293	25 ft.	Cable (16/3 SJTO)
5	420050-2	1	Gasket
6	420050-3	1	Switch Mounting Plate
7	251818	1	Strain Relief Connector
8	251802	1	Locknut (3/4-16 UNF)
9	420050-4	1	Switch Housing
10	12311	3	Ring Tongue Terminal
11	16773	1	Rocker Switch
12	253607	1	Rubber Seal