

Parts List for:

PE604T  
 PE604T-220  
 PE604PT  
 PE604PT-220

**MODEL B**  
**ELECTRIC TWO-STAGE HYDRAULIC PUMP**

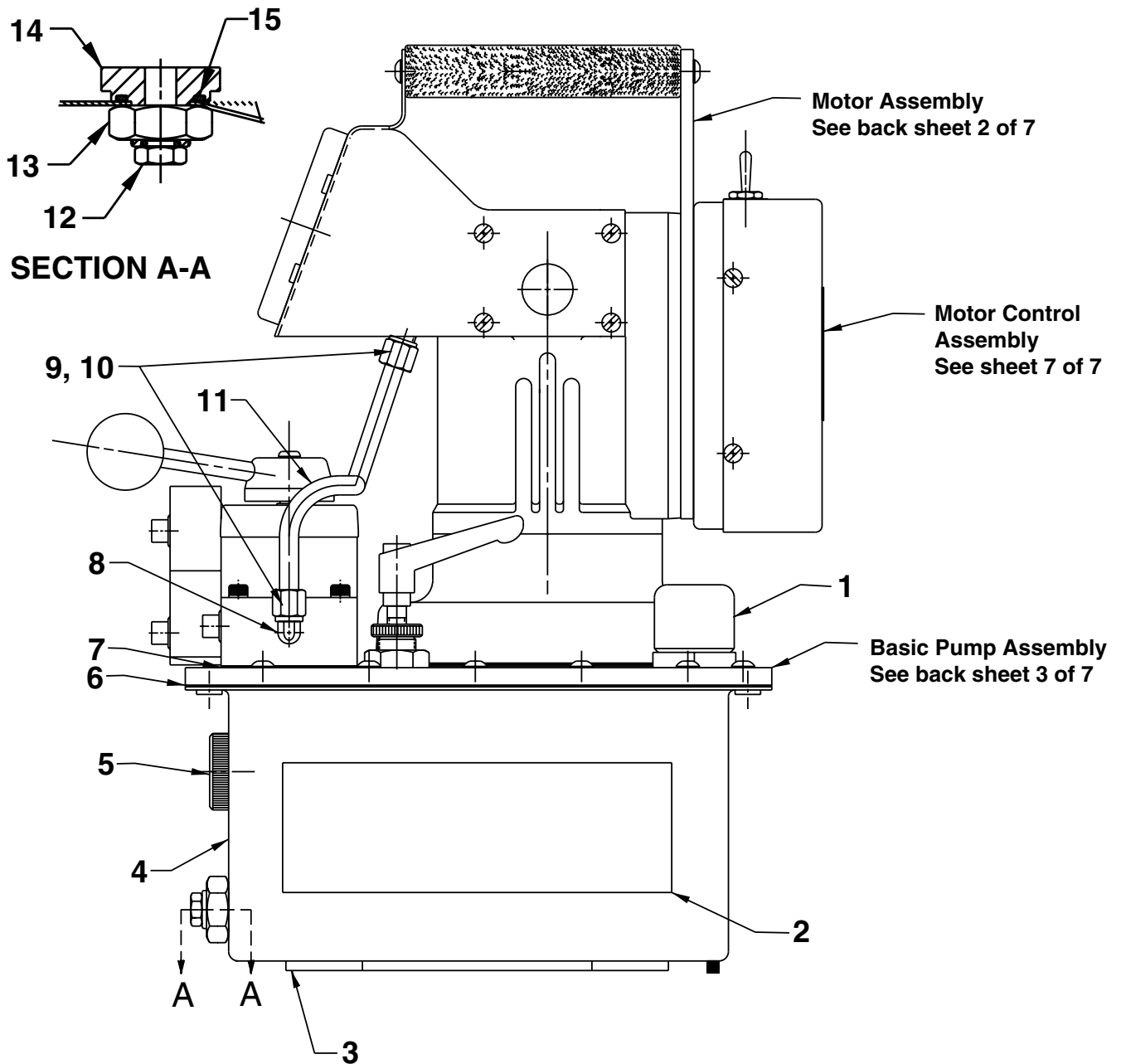

Item No.	Part No.	No. Req'd	Description
1	252987	1	Vent Breather
2	309219	2	Trade Name Decal
3	420948	1	Rubber Pad
4	65698OR9	1	Steel Reservoir
5	17586	1	Sight Gauge
6	58843	1	Reservoir Gasket
7	252497	1	Valve Gasket
8	10665	1	90° Elbow Fitting (Note: Remove nut and ferrule.)
9	214269	2	Nut Fitting
10	214270	2	Tube Sleeve
11	252496	1	Oil Line Tube
12	17147	1	Plug Fitting
13	10396	1	Jam Nut
14	351000	1	Drain
15	14725	1	O-ring (1-1/8" X 15/16 X 3/32)



### HYDRAULIC SCHEMATIC

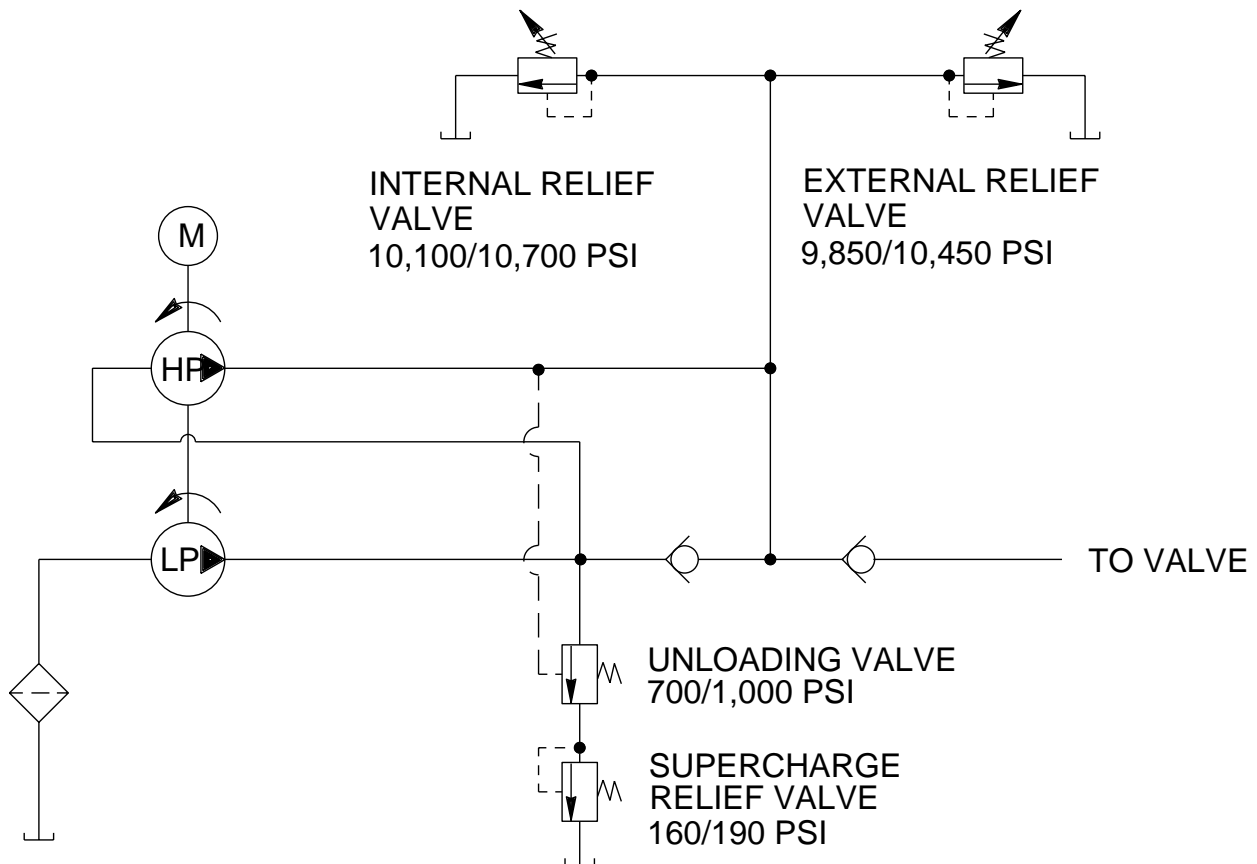

**PUMP TOP VIEW**

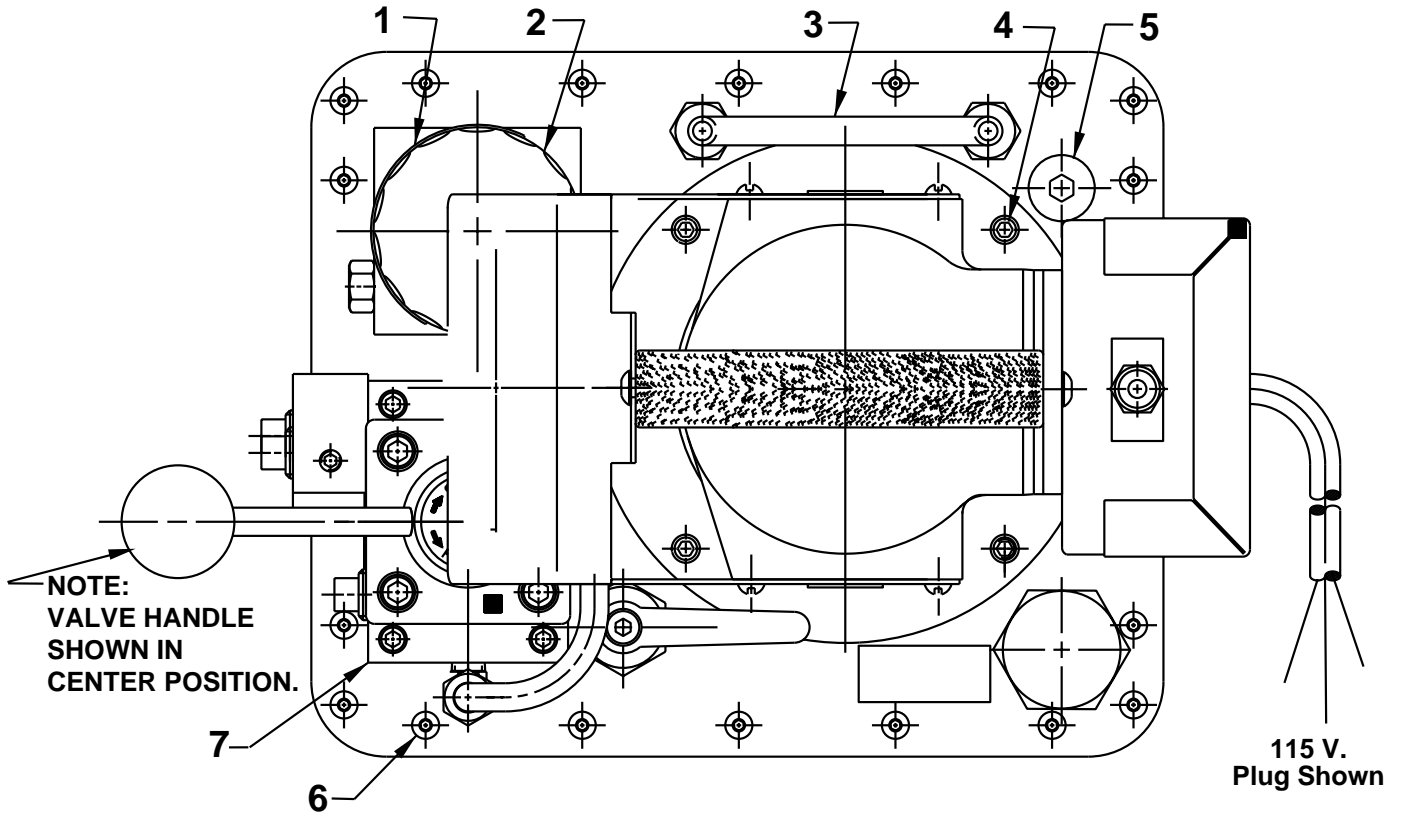

Item No.	Part No.	No. Req'd	Description
1	309219	1	Trade Name Decal
2	252425	1	Oil Filter
3	252495	1	Oil Line Tube
4	10016	4	Screw (1/4-20 UNC X 1" Lg.; Apply Loctite 242)
5	214014	1	Plug Fitting
6	250383	20	Screw (1/4-20 UNC x 3/4 Lg.)
7	9500HD	1	Manual Valve (For PE604T & PE604T-220; See Form No. 101824)
	9628	1	Manual Valve (For PE604PT & PE604PT-220; See Form No. 101810)

### MOTOR ASSEMBLY

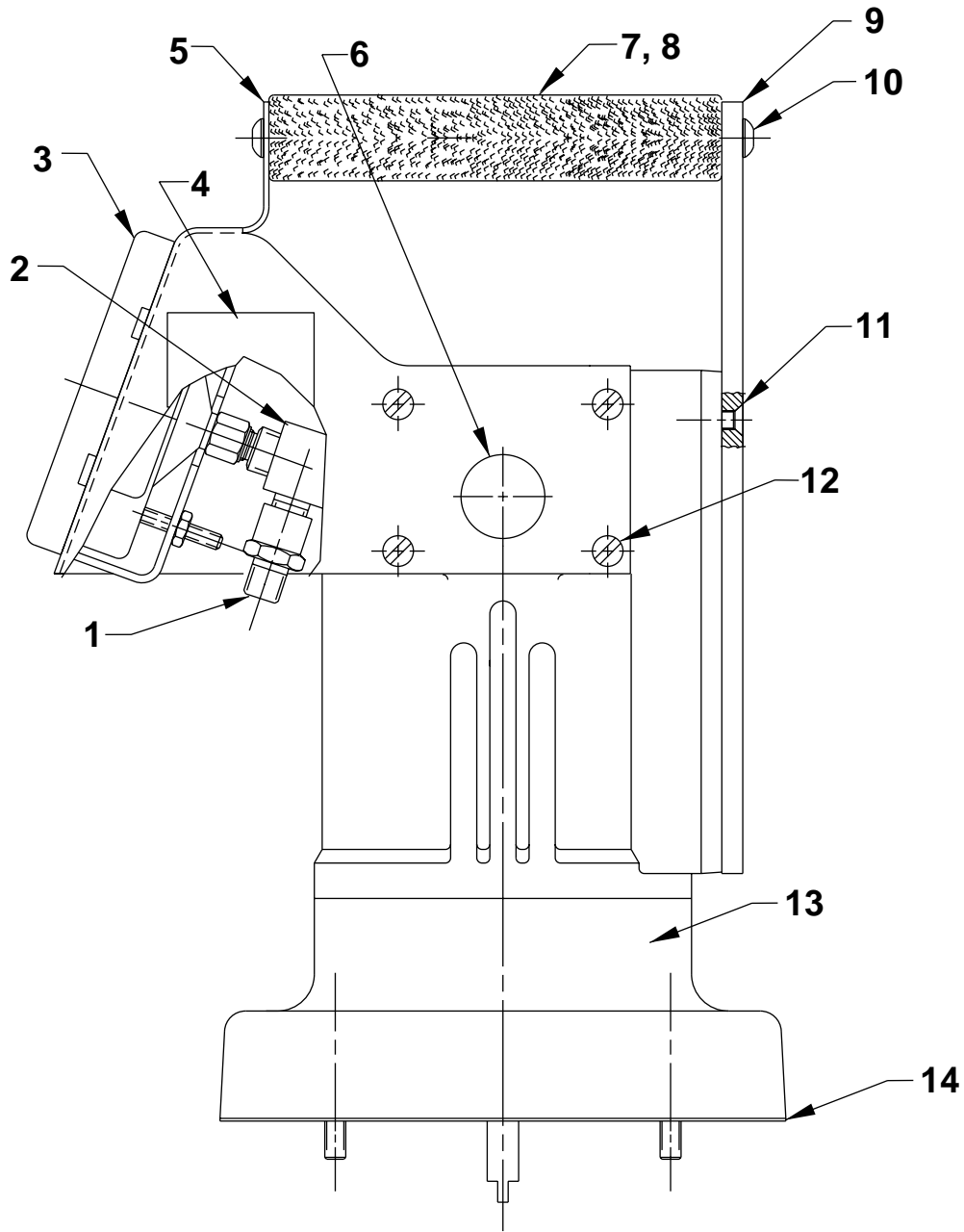

Item No.	Part No.	No. Req'd	Description
1	252528	1	Straight Fitting
2	16823	1	90° Elbow Fitting
3	252426	1	Gauge (10,000 PSI; 4" dia.)
4	215364	1	Specifications Decal (110/115 V.; 50/60 Hz.)
	215363	1	Specifications Decal (220/230 V.; 50/60 Hz.)
5	58884WH2	1	Gauge Bracket
6	19502	2	Hole Plug
7	252154	1	Handle
8	251600	1	Handle Grip
9	351388WH2	1	Handle Bracket
10	251437	2	Screw (1/4-20 UNC x 1/2 Lg.)
11	252529	3	Screw (#10-24 UNC x 1/2 Lg.)
12	11539	8	Screw (#10-24 X 1/4 Lg.)
13	65420	1	Electric Motor (110/115 V. , 50/60 Hz.; See sheet 3 of 7)
	65574	1	Electric Motor (220/230 V., 50/60 Hz.; See sheet 3 of 7)
14	30650	1	Motor Base Gasket

# UNIVERSAL MOTOR

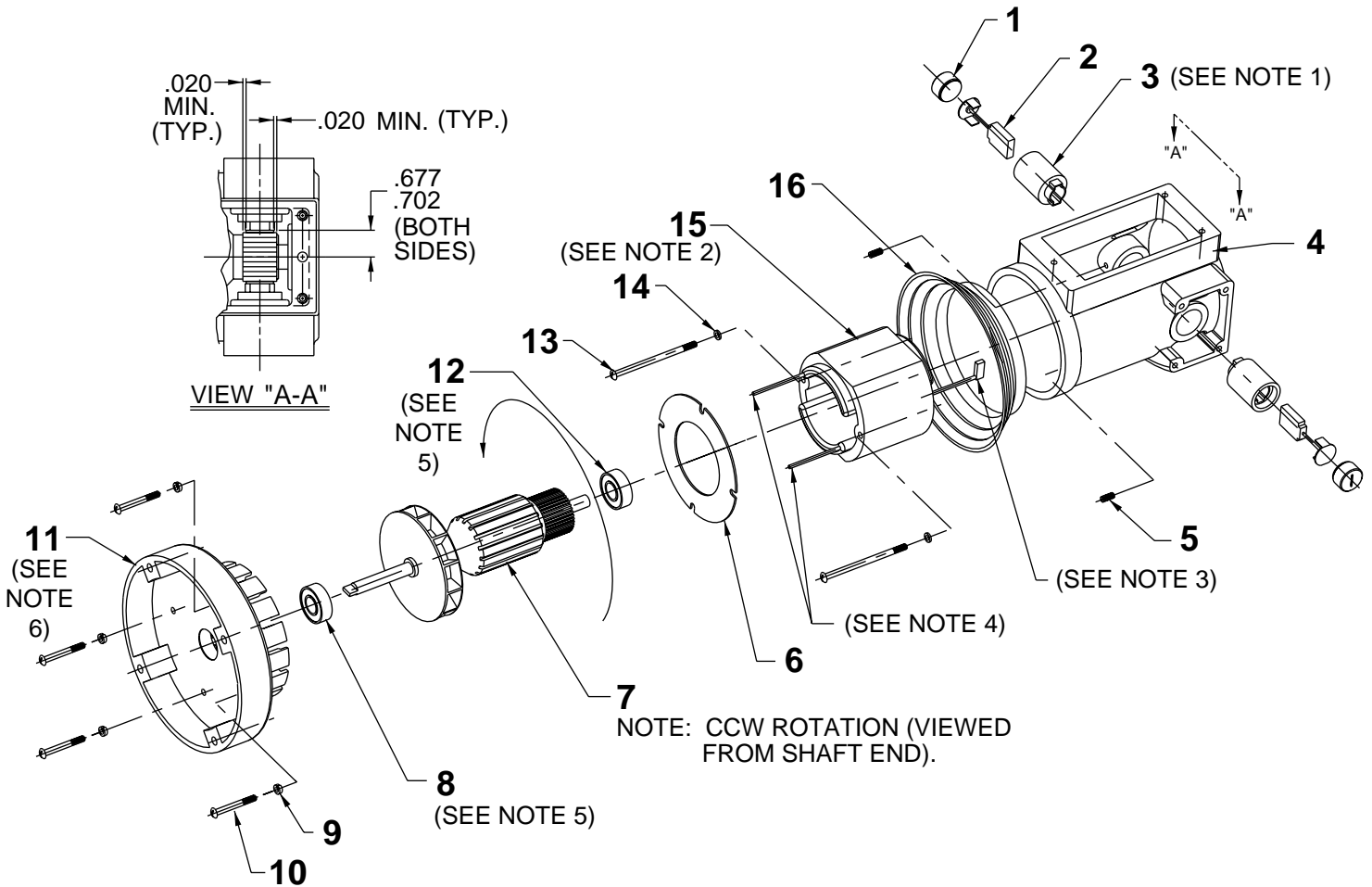

Item No.	Part No.	No. Req'd	Description
1	10806	2	Brush Holder Cap
2	10804	2	Brush
3	10805	2	Brush Holder
4	65479WH2	1	Motor Shell
5	10133	2	Screw (#10-24 UNC X 1/4 Lg.)
6	20786	1	Baffle Plate
7	10800	1	Armature (115 V.)
	58841A	1	Armature (230 V.)
8	10438	1	Ball Bearing
9	10241	4	Lockwasher (For #10 bolt)

Item No.	Part No.	No. Req'd	Description
10	10169	4	Screw (#10-24 UNC X 2" Lg.; Torque to 20/25 in. lbs.)
11	351416WH2	1	Motor Base
12	10439	1	Ball Bearing
13	10170	2	Screw (#10-24 UNC X 3-1/4 Lg.)
14	12356	2	Washer (#10 Internal Tooth)
15	10802	1	Field (115 V.)
	58841F	1	Field (230 V.)
16	421204	1	Plastic Cover

- Notes:**
- Brush holders (Item #3) must be installed with slot and dimple facing the open end of the motor shell casting.
  - Stator must be installed with part no. and date code up (must be visible through the rectangular opening in the motor shell casting).
  - Insert flag terminals into adjacent brush holders.
  - Line leads must be routed through the rectangular opening in the motor shell casting.
  - Press bearings into armature and install as a unit into the motor shell casting.
  - Casting number must be on top when the motor base casting is fastened to the motor shell casting.

## GENERAL PUMP ASSEMBLY

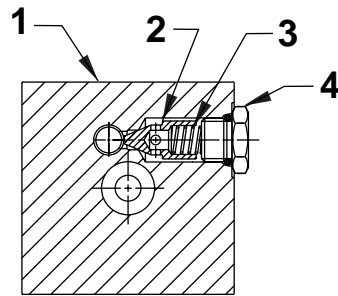

**SECTION A-A**

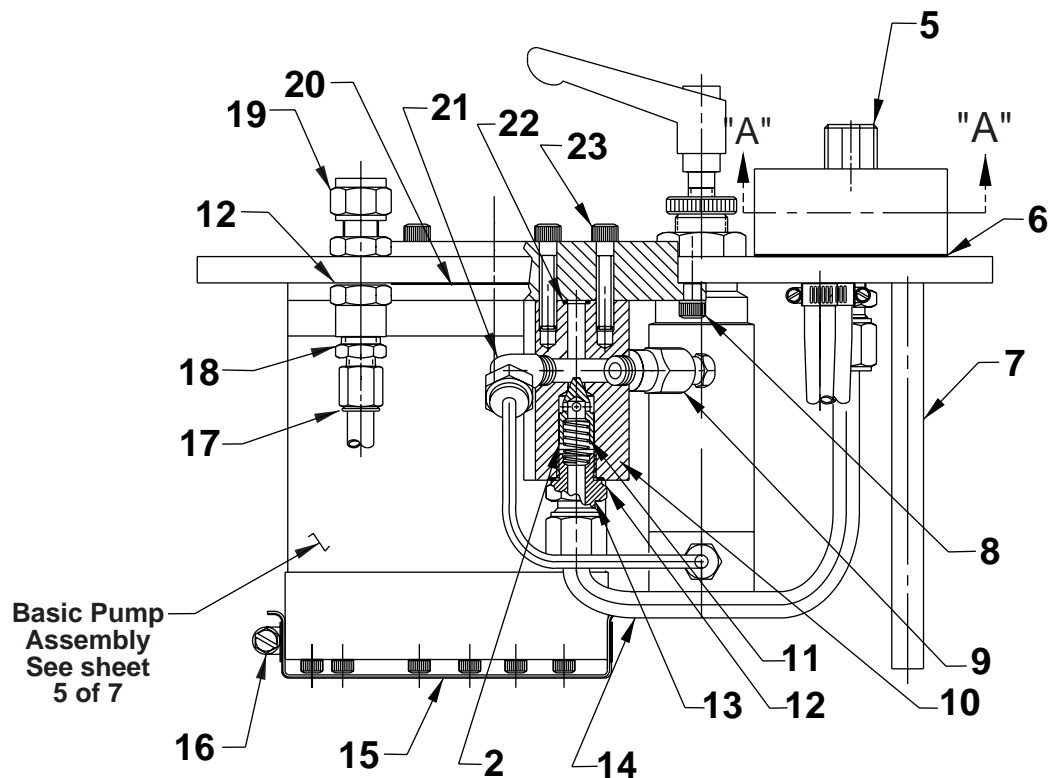

Item No.	Part No.	No. Req'd	Description
1	421604	1	Filter Manifold
2	20771	2	Poppet
3	252231	1	Compression Spring
4	252635	1	Plug Fitting
5	252428	1	Straight Fitting
6	252367	1	Valve Gasket
7	14463	1	Straight Fitting
8	10006	3	Screw (1/4-20 UNC X 5/8 Lg.; Apply Loctite 242 and torque to 60 in. lbs.)
9	21278	1	Relief Valve Assembly (Set at 10,100/10,700 PSI)
10	20776	1	Valve Body
11	10425	1	Compression Spring (3/8 O.D. X 3/4 Lg.)

Item No.	Part No.	No. Req'd	Description
12	10261	3	Copper Washer (3/4 X 19/32 X 1/32)
13	20770	1	Connector Fitting
14	252494	1	Oil Line Tube
15	350304	1	Filter
16	350995	1	Hose Clamp
17	252986	4	Straight Fitting
18	206324	2	Straight Fitting
19	252483	2	Straight Fitting (Torque locking nut to 225 in. lbs.)
20	252366	1	Top Plate Gasket
21	16177	1	90° Elbow Fitting
22	10266	1	O-ring (3/8 X 1/4 X 1/16)
23	252482	2	Screw (1/4-28 UNF-2B x 1-1/2 Lg.)

## GENERAL PUMP ASSEMBLY REGULATOR

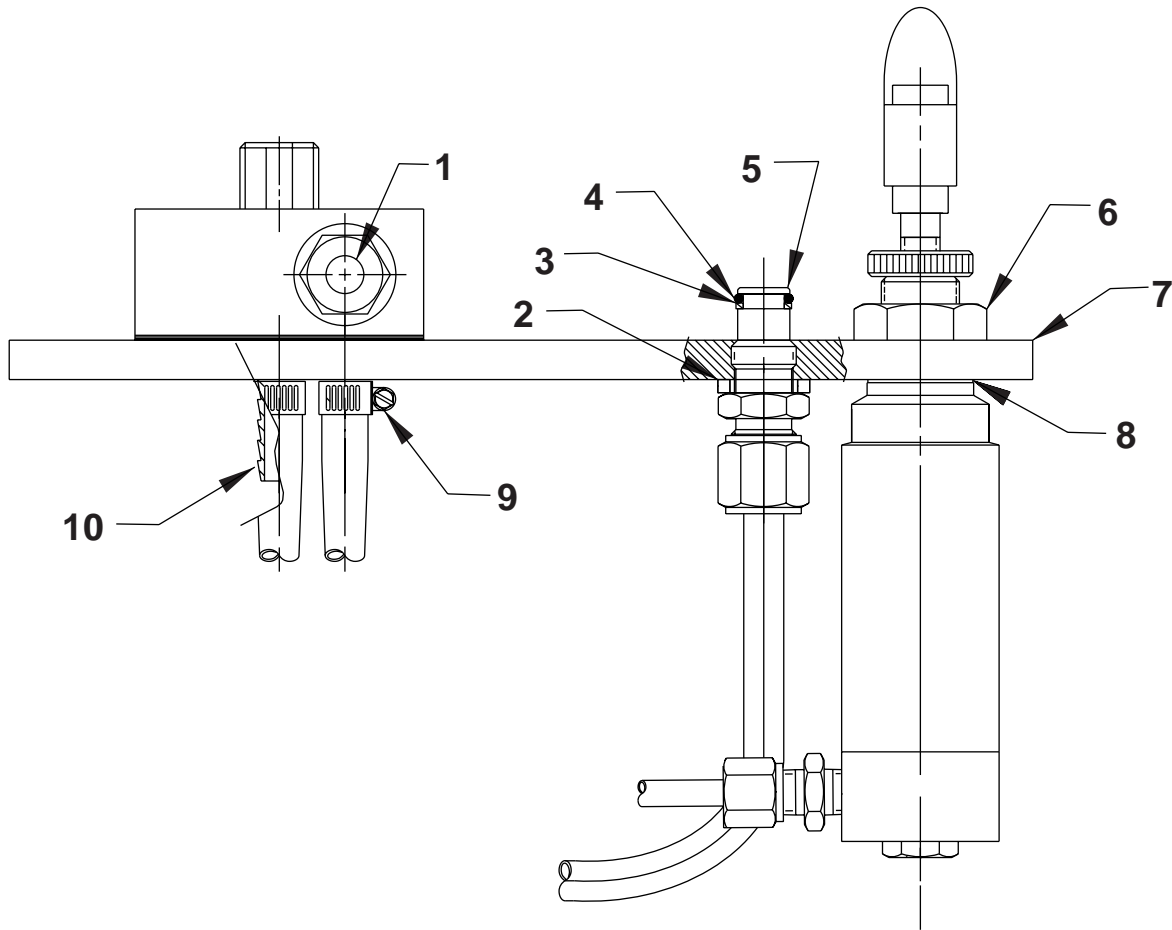

Item No.	Part No.	No. Req'd	Description
1	215907	1	Instruction Decal
2	21484	1	Spacer
3	11863	1	Backup Washer (1/2 X 3/8 X 1/16)
4	10268	1	O-ring (1/2 X 3/8 X 1/16)
5	20787	1	Valve Connector
6	421429	1	Pressure Regulator Assembly (See sheet 6 of 7)
7	65697WH2	1	Cover Plate
8	10263	1	Copper Washer (1" X .765 X 1/32)
9	210331	2	Hose Clamp
10	250130	2	Hose Fitting

**BOTTOM VIEW**

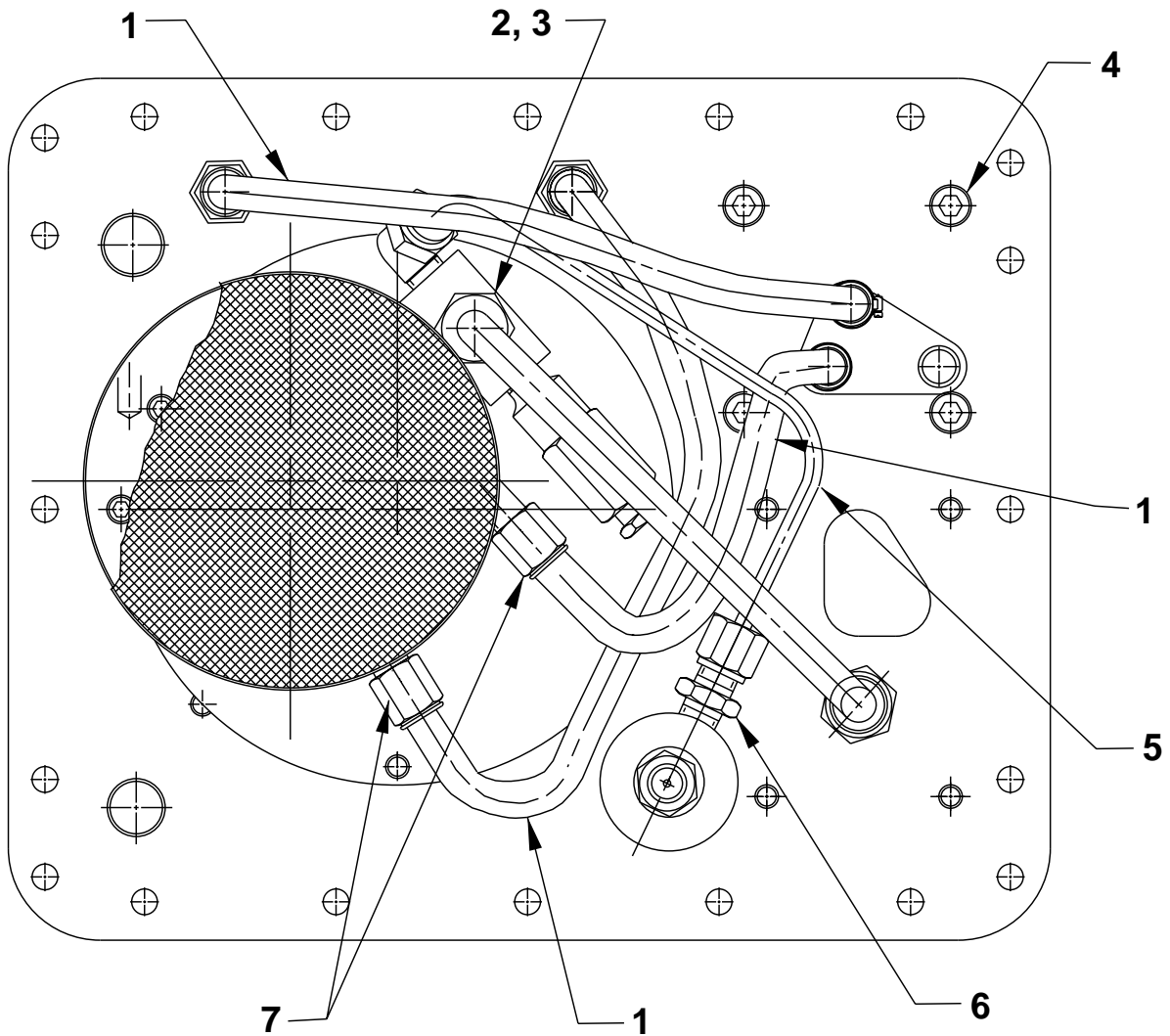

Item No.	Part No.	No. Req'd	Description
1	252226	3 ft.	Nylon Tubing
2	10430	2	Tube Sleeve
3	10431	2	Tube Nut Fitting
4	10008	4	Screw (1/4-20 UNC X 3/4 Lg.)
5	252493	1	Oil Line Tube
6	14844	1	Straight Fitting
7	208218	4	Straight Fitting

**BASIC PUMP ASSEMBLY - VIEW 1**

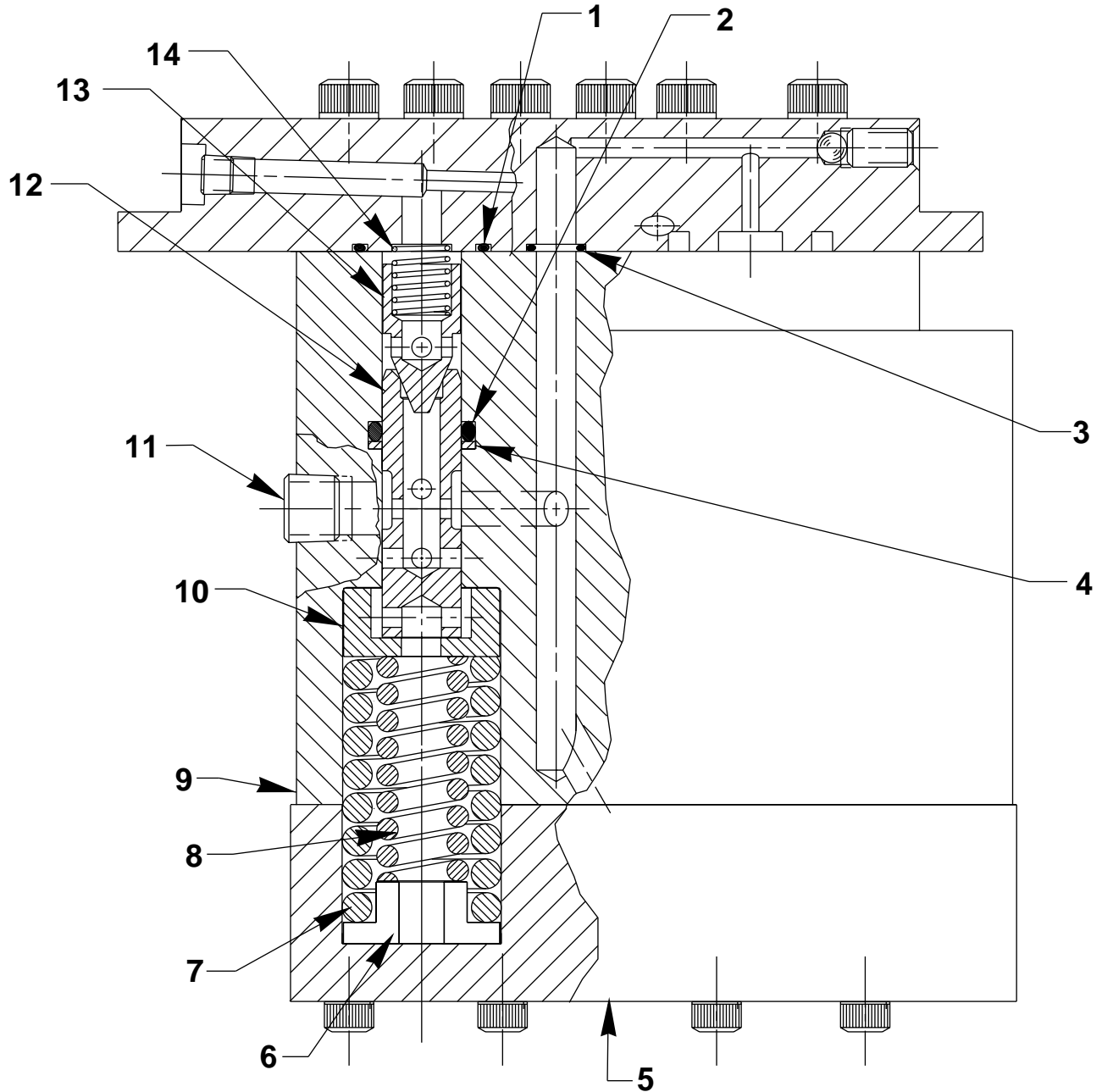

Item No.	Part No.	No. Req'd	Description
1	10303	1	O-ring (7/8 X 3/4 X 1/16)
2	10271	1	O-ring (11/16 X 1/2 X 3/32)
3	10266	1	O-ring (3/8 X 1/4 X 1/16)
4	12389	1	Backup Washer (11/16 x 1/2 X 1/16)
5	65417	1	End Plate
6	252637	1	Spacer
7	10426	1	Compression Spring (1" O.D. X 1-13/16 Lg.)

Item No.	Part No.	No. Req'd	Description
8	206001	1	Spring (37/64 O.D. X 1-1/2" Lg.)
9	65416	1	Pump Body
10	23255	1	Spring Guide
11	10427	1	Plug Fitting
12	20849	1	Spool
13	20771	1	Poppet
14	10425	1	Compression Spring (3/8 O.D. X 3/4 Lg.)



### BASIC PUMP ASSEMBLY - VIEW 2

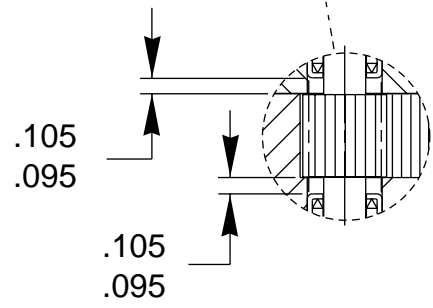
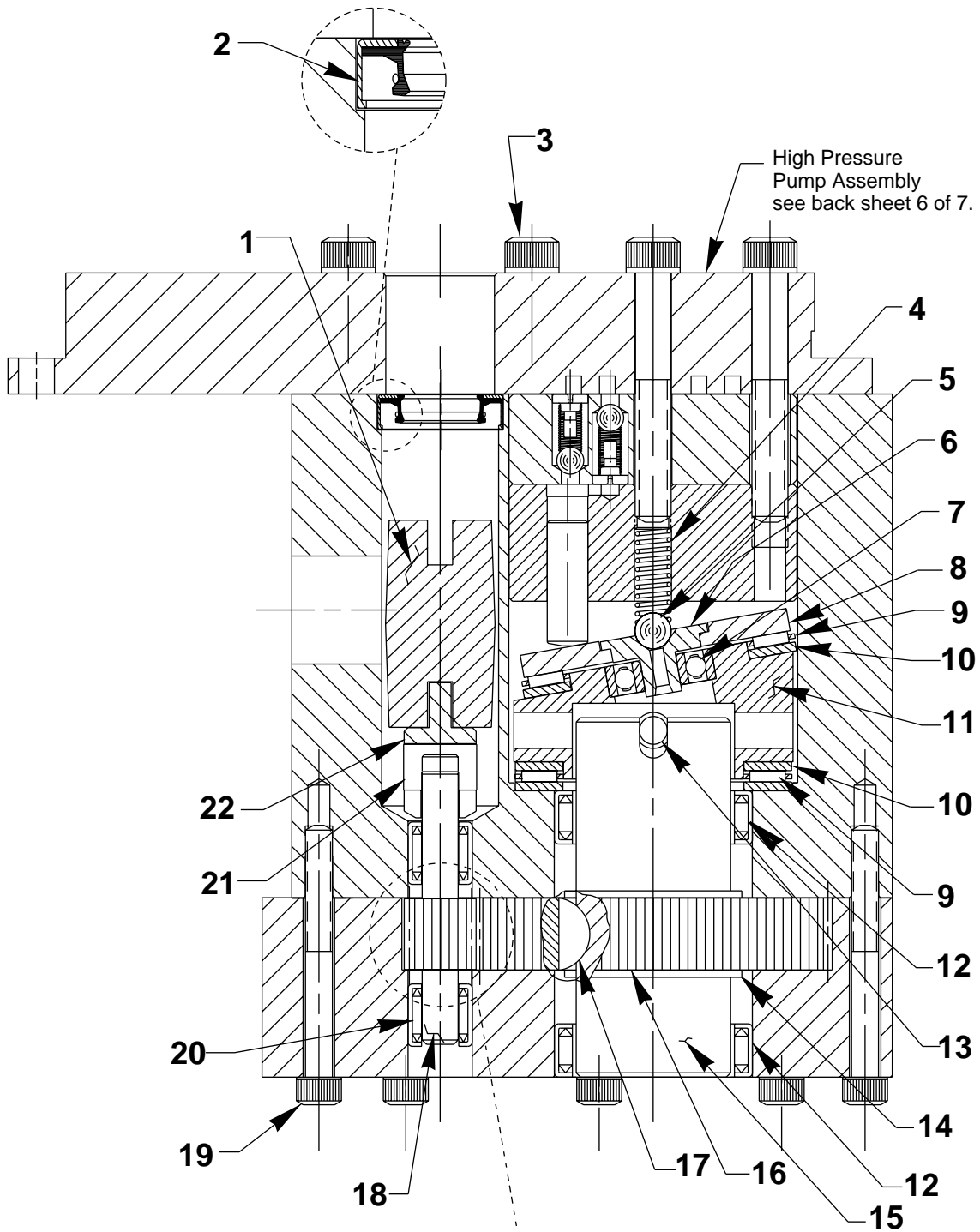

Item No.	Part No.	No. Req'd	Description
1	252108	1	Coupling
2	252429	1	Oil Seal
3	10022	9	Screw (1/4-20 UNC X 1-1/2 Lg.; Torque to 170/180 in. lbs.)
4	10361	1	Compression Spring (1/4 O.D. X 1" Lg.)
5	10375	1	Ball (1/4 Dia.)
6	23547	1	Bearing Top Plate
7	11814	1	Ball Bearing
8	23548	1	Top Plate
9	11228	2	Needle Bearing
10	11227	3	Bearing Race
11	351004	1	Angle Plate



Item No.	Part No.	No. Req'd	Description
12	11064	2	Needle Bearing
13	11955	1	Slotted Spring Pin
14	11261	2	Retaining Ring
15	23556	1	Shaft
16	23574	1	Drive Gear
17	11821	1	Woodruff Key
18	20774	1	Drive Gear
19	10001	13	Screw (#10-32 UNF X 1-3/4 Lg.; Torque to 50/60 in. lbs.)
20	11198	2	Needle Bearing
21	21093	1	Key
22	21092	1	Adapter

### PRESSURE REGULATOR ASSEMBLY

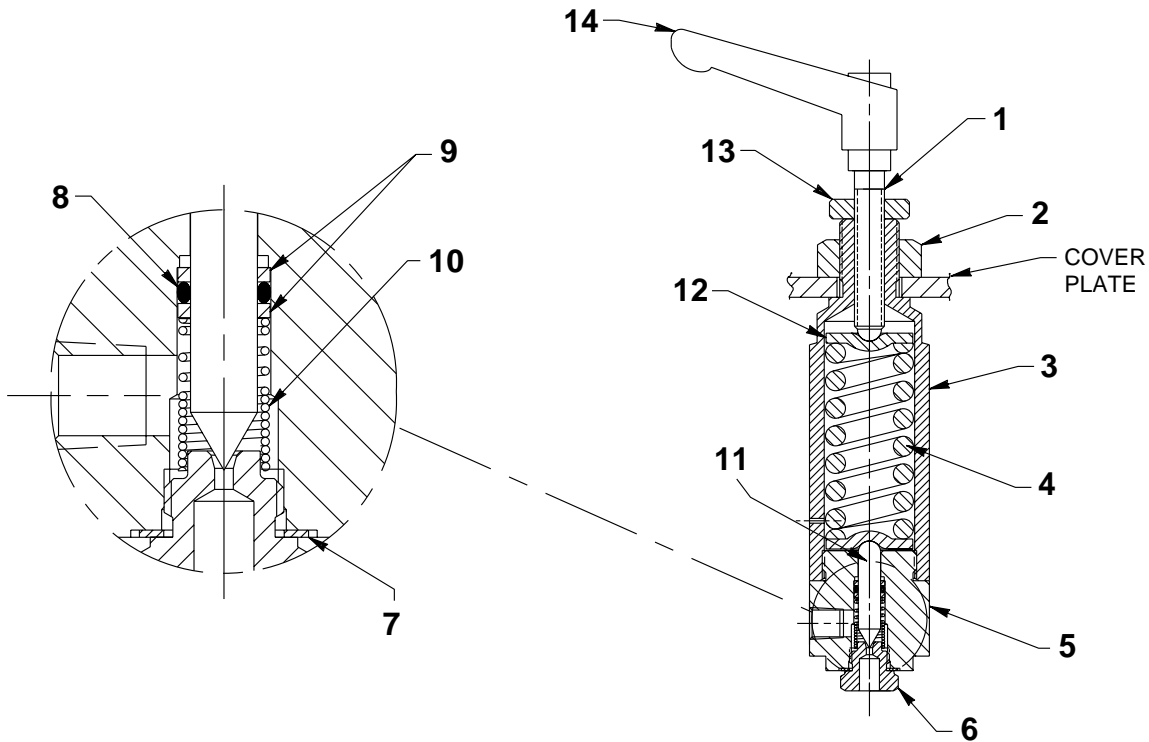

Item No.	Part No.	No. Req'd	Description
1	252427	1	Adjustment Stem (Note: Assemble to handle with Loctite 242 or equiv.)
2	10396	1	Jam Nut
3	351350	1	Regulator Housing
4	215429	1	Compression Spring (1.100 O.D. X 2-1/2 Lg.)
5	420891	1	Regulator Body
6	351343	1	Seat Fitting (Torque to 440/460 in. lbs.)
7	14874	1	Copper Washer (.700 X 1/2 X 1/32)

Item No.	Part No.	No. Req'd	Description
8	10266	1	O-ring (3/8 X 1/4 X 1/16)
9	215430	2	Backup Washer (.385 x .282 x .050)
10	215431	1	Spring (3/8 O.D. x 21/32 Lg.; Note: Assemble closed coils of spring form towards seat fitting [Item#6])
11	309079	1	Poppet
12	215428	2	Spring Retainer (Grease pocket before assembling [both ends])
13	215683	1	Regulator Locking Nut
14	252332	1	Adjustable Handle

## HIGH PRESSURE PUMP ASSEMBLY

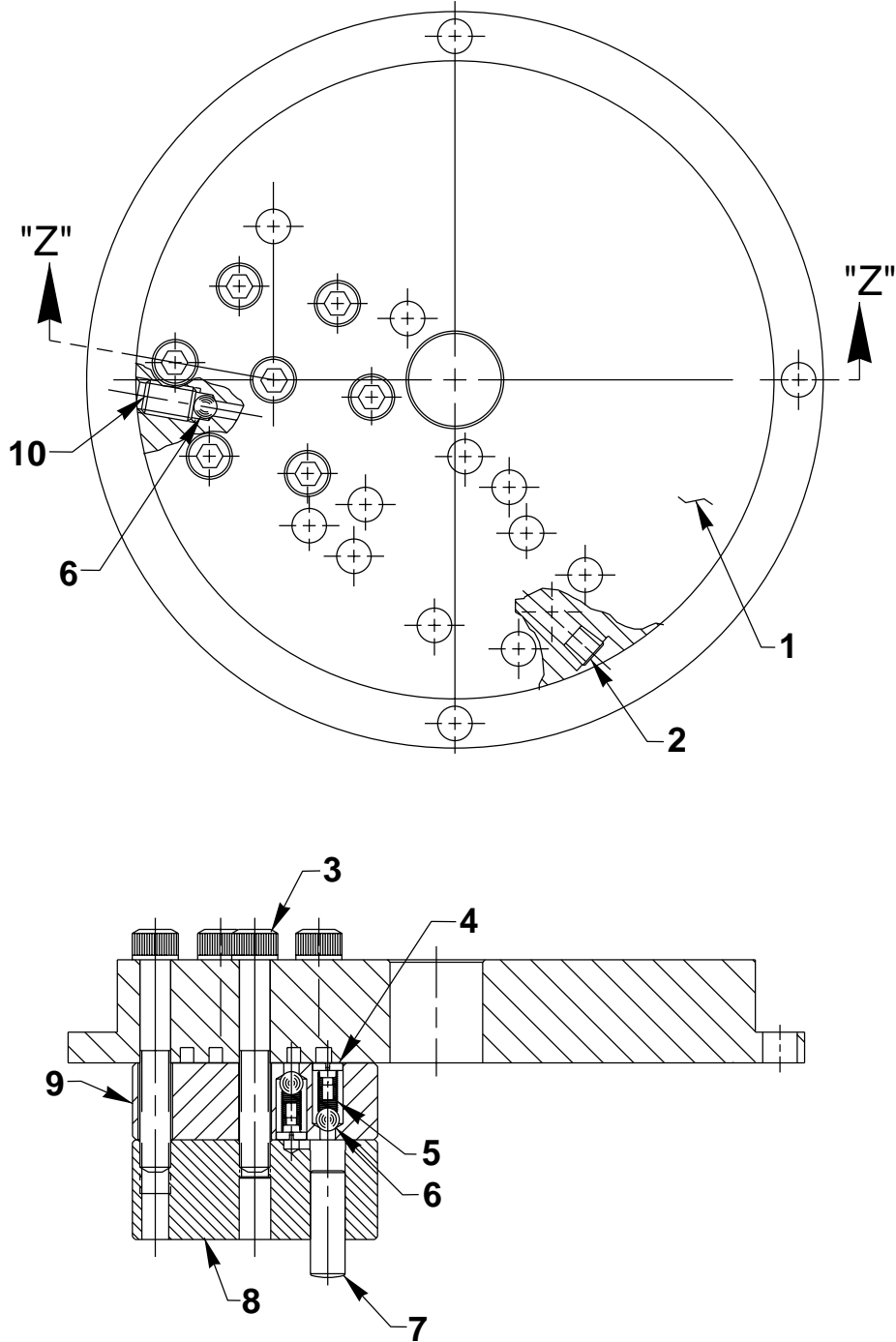

Item No.	Part No.	No. Req'd	Description
1	65377	1	Top Plate
2	15130	1	Plug Fitting (Apply thread tape and torque to 130/150 in. lbs.)
3	252475	7	Soc. Hd. Cap Screw (1/4-28 UNF-2B x 1-3/4 Lg.; Torque to 170/180 in. lbs.)
4	24549	6	Ball Guide
5	10445	6	Compression Spring (5/32 O.D. X 3/4" Lg.)
6	12223	7	Steel Ball (3/16" Dia.)
7	21628	3	Piston
8	41062	1	Pump Barrel
9	421473	1	Valve Head
10	10519	1	Soc. Set Screw (1/4-20 UNC X 3/8 Lg.; Torque to 65/70 in. lbs.)

### MOTOR CONTROL ASSEMBLY

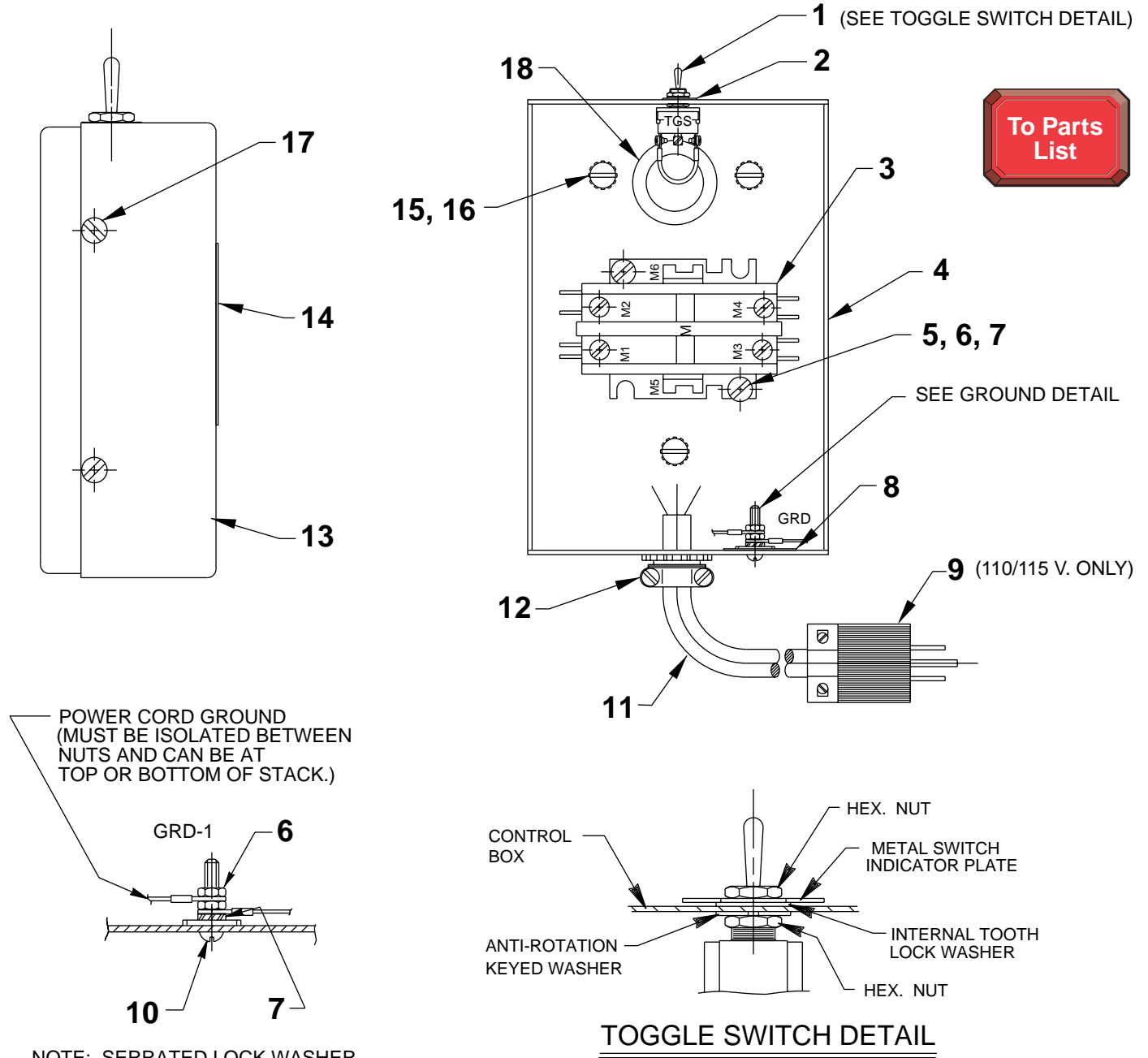

To Parts List

NOTE: SERRATED LOCK WASHER MUST BE ADJACENT TO METAL BOX. MORE WASHERS CAN BE USED IF DESIRED.

GROUND DETAIL

Item No.	Part No.	No. Req'd	Description
1	12175	1	Switch (On/Off/Momentary)
2	203912	1	Decal (On/Off/Jog)
3	420718-1	1	Contactor (110/115 V., 50/60 Hz.)
	420718-2	1	Contactor (220/230 V., 50/60 Hz.)
4	42575WH2	1	Electrical Control Box
5	12354	2	Screw (10-24 UNC X 5/8 Lg.)
6	10197	4	Hex Nut (#10-24 UNC)
7	11108	3	Washer (#10 External Tooth)
8	205189	1	Ground Decal
9	16896	1	Electrical Plug (110/115 V. only)
10	10167	1	Screw (#10-24 UNC X 3/4 Lg.)

Item No.	Part No.	No. Req'd	Description
11	307439	1 ft.	Electrical Cable (110/115 V., 50/60 Hz.)
	307852	1 ft.	Electrical Cable (220/230 V., 50/60 Hz.)
12	11203	1	Conduit Connector
13	42576WH2	1	Control Box Cover
14	200188	1	Warning Decal
15	10447	3	Screw (#8-32 UNC X 5/16 Lg.)
16	11388	3	Washer (#8 External Tooth)
17	11141	4	Screw (#6-20 X 3/8 Lg.)
18	15497	1	Rubber Grommet



**ELECTRICAL SCHEMATIC**  
115/220 V., 50/60 Hz. Single Phase

