

MODEL C
ELECTRIC TWO-STAGE HYDRAULIC PUMP

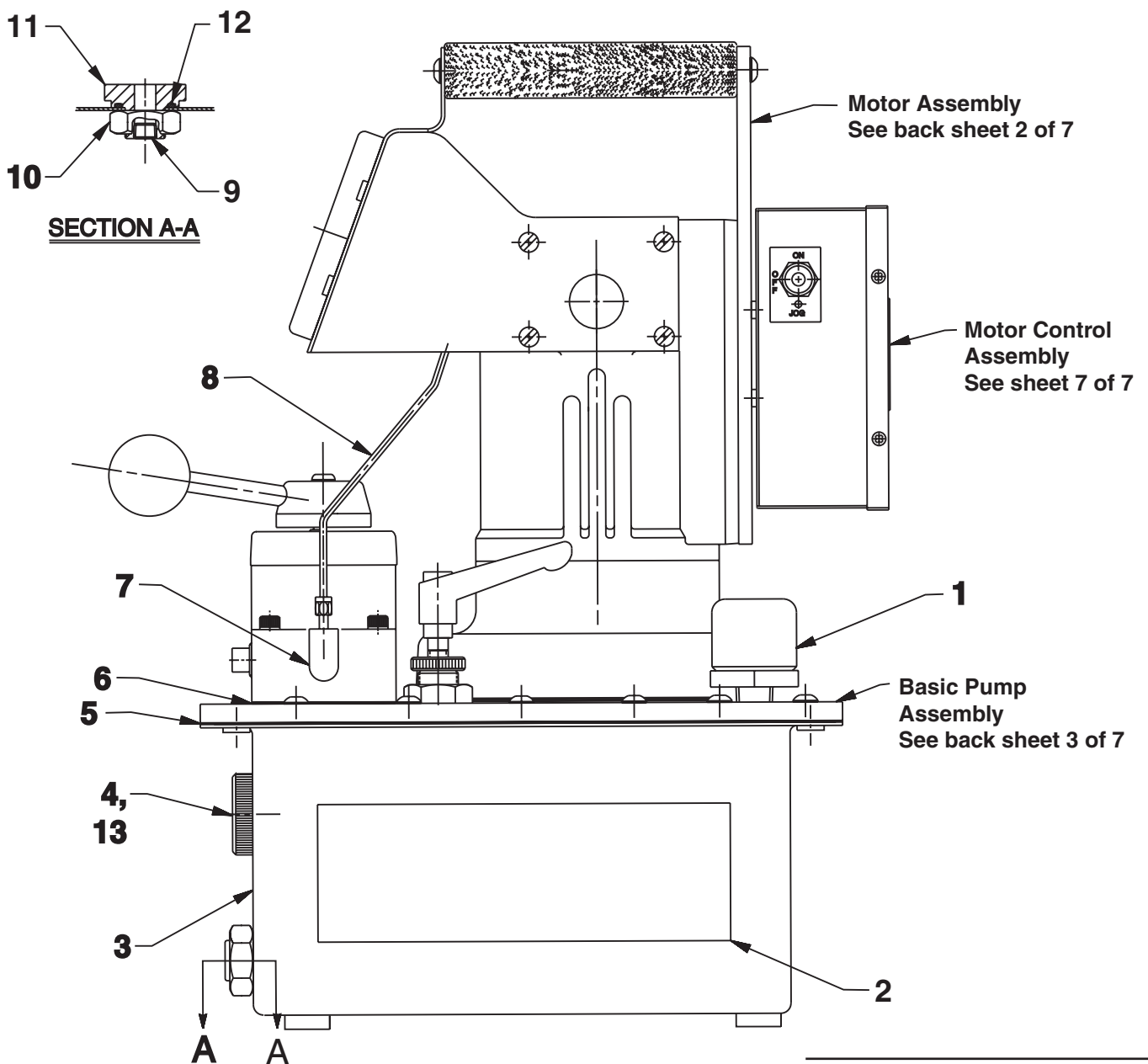

Item No.	Part No.	No. Req'd	Description
1	252987	1	Vent Breather
2	309219	2	Trade Name Decal
3	65795OR9	1	Steel Reservoir
4	17586	1	Sight Gauge
5	59063	1	Reservoir Gasket
6	200395	1	Valve Gasket
7	253159	1	90° Elbow Fitting (1/4 NPTincludes nut and ferrule)
8	351718	1	Oil Line Tube
9	250883	1	Plug Fitting (1/4 Tube)
10	10396	1	Jam Nut
11	351000	1	Drain
12	14725	1	O-ring (1-1/8" X 15/16 X 3/32)
13	253300	1	Seal Washer

Note: Shaded areas reflect last revision(s) made to this form.

HYDRAULIC SCHEMATIC

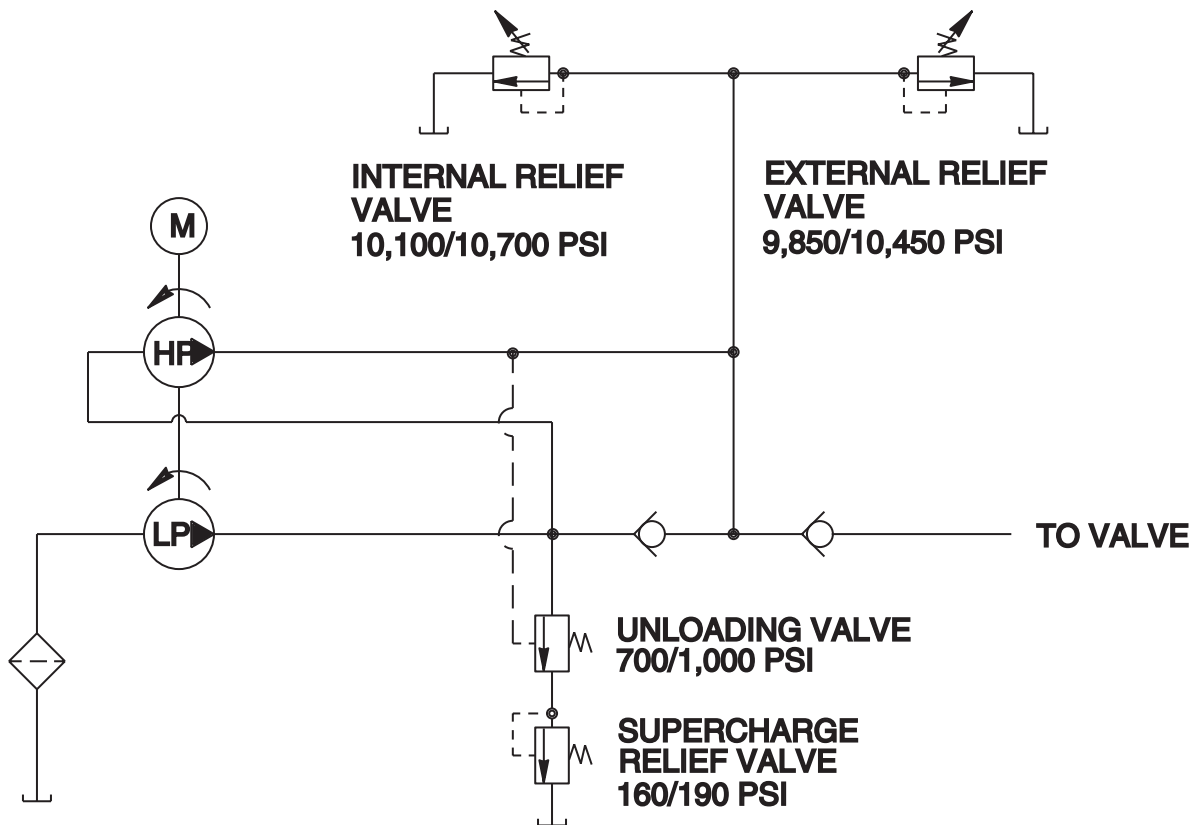

PUMP TOP VIEW

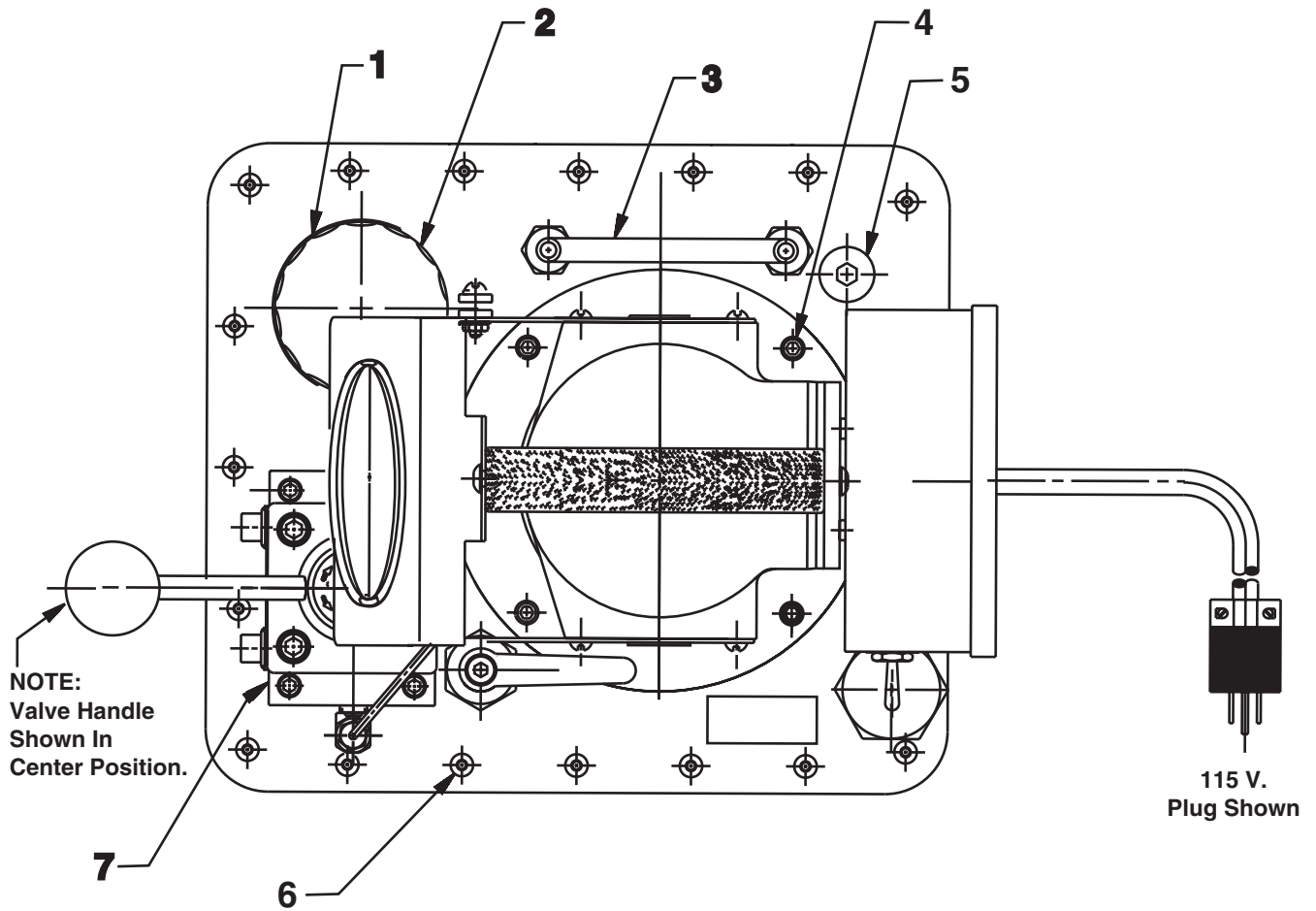

Item No.	Part No.	No. Req'd	Description
1	309219	1	Trade Name Decal
2	252425	1	Oil Filter
3	252495	1	Oil Line Tube
4	10022	4	Screw (1/4-20 UNC X 1" Lg.; Apply Loctite 242)
5	214014	1	Plug Fitting
6	10177	20	Screw (1/4-20 UNC x 3/4 Lg.)
7	9500HD	1	Manual Valve (For PE604T & PE604T-220; See Form No. 101824)
	9628	1	Manual Valve (For PE604PT & PE604PT-220; See Form No. 101810)

MOTOR ASSEMBLY

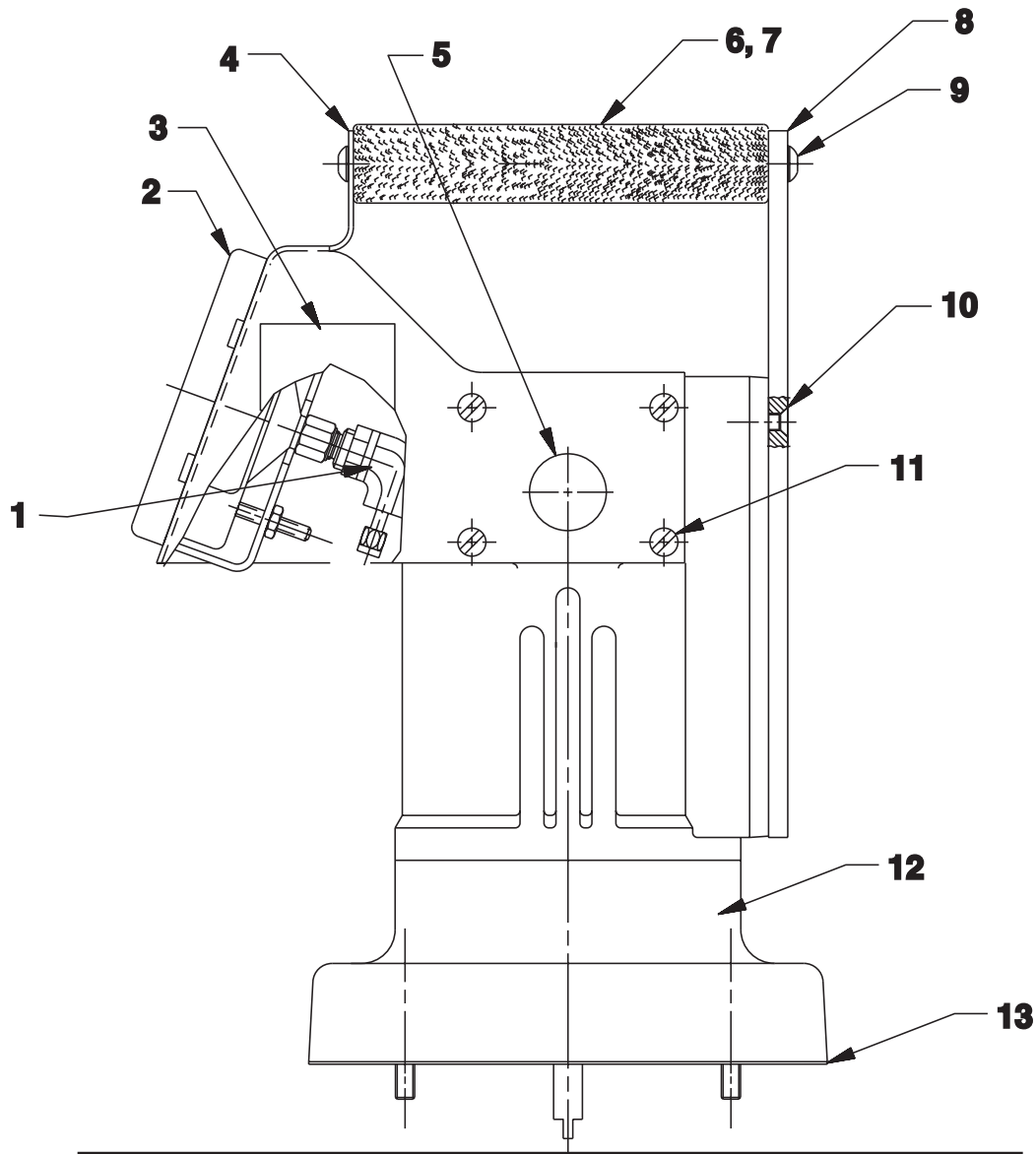

Item No.	Part No.	No. Req'd	Description
1	253160	1	90° Elbow Fitting (1/4 NPT Includes nut and ferrule)
2	252426	1	Gauge (10,000 PSI; 4" dia.)
3	215164	1	Specifications Decal (110/115 V.; 50/60 Hz.)
	215163	1	Specifications Decal (220/230 V.; 50/60 Hz.)
4	58884WH2	1	Gauge Bracket
5	19502	2	Hole Plug
6	252154	1	Handle
7	251600	1	Handle Grip
8	351663WH2	1	Handle Bracket
9	251437	2	Screw (1/4-20 UNC x 1/2 Lg.)
10	252529	3	Screw (#10-24 UNC x 1/2 Lg.)
11	11539	8	Screw (#10-24 X 1/4 Lg.)
12	65802	1	Electric Motor (110/115 V. , 50/60 Hz.; See sheet 3 of 7)
	65836	1	Electric Motor (220/230 V., 50/60 Hz.; See sheet 3 of 7)
13	30650	1	Motor Base Gasket

Note: Shaded areas reflect last revision(s) made to this form.

UNIVERSAL MOTOR

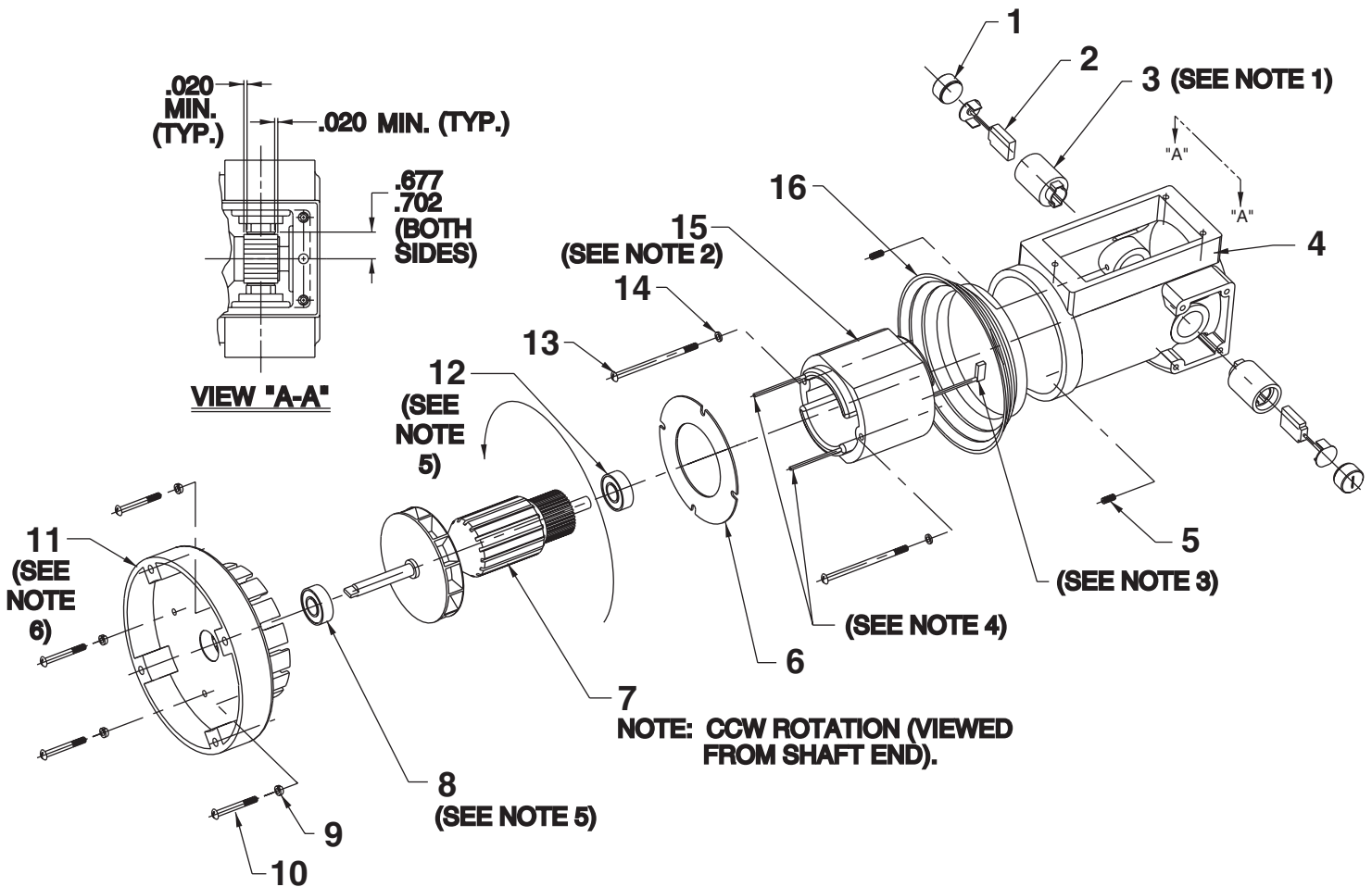

Item No.	Part No.	No. Req'd	Description
1	10806	2	Brush Holder Cap
2	10804	2	Brush
3	10805	2	Brush Holder
4	65479WH2	1	Motor Shell
5	10133	2	Screw (#10-24 UNC X 1/4 Lg.)
6	20786	1	Baffle Plate
7	10800	1	Armature (115 V.)
	58841A	1	Armature (230 V.)
8	10438	1	Ball Bearing
9	10241	4	Lockwasher (For #10 bolt)

Item No.	Part No.	No. Req'd	Description
10	10169	4	Screw (#10-24 UNC X 2" Lg.; Torque to 20/25 in. lbs.)
11	40059WH2	1	Motor Base
12	10439	1	Ball Bearing
13	10170	2	Screw (#10-24 UNC X 3-1/4 Lg.)
14	12356	2	Washer (#10 Internal Tooth)
15	10802	1	Field (115 V.)
	58841F	1	Field (230 V.)
16	421204	1	Plastic Cover

- Notes:**
- Brush holders (Item #3) must be installed with slot and dimple facing the open end of the motor shell casting.
 - Stator must be installed with part no. and date code up (must be visible through the rectangular opening in the motor shell casting).
 - Insert flag terminals into adjacent brush holders.
 - Line leads must be routed through the rectangular opening in the motor shell casting.
 - Press bearings into armature and install as a unit into the motor shell casting.
 - Casting number must be on top when the motor base casting is fastened to the motor shell casting.

GENERAL PUMP ASSEMBLY

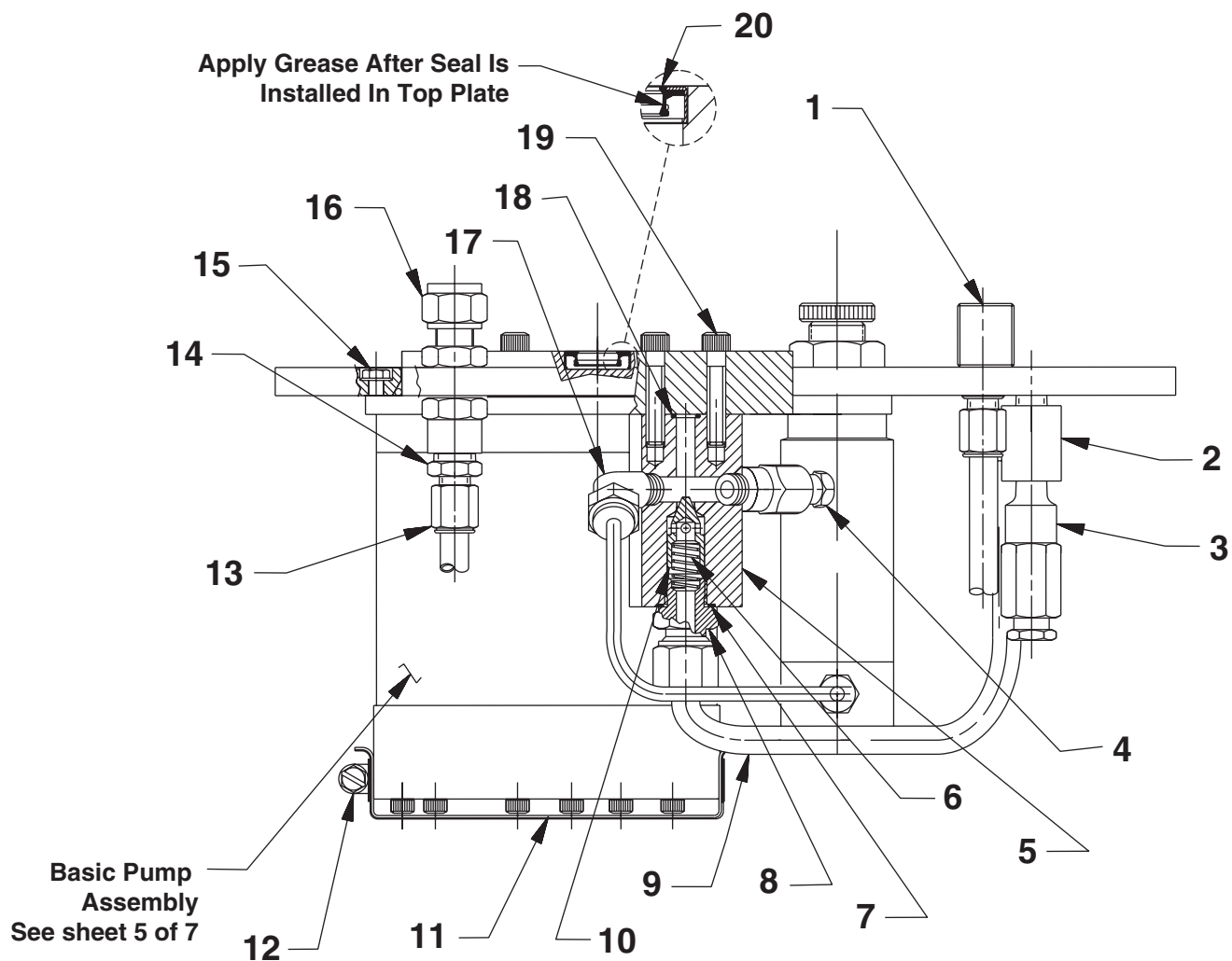

Item No.	Part No.	No. Req'd	Description
1	253119	1	Fitting (Assemble with loctite 242)
2	19463	1	Fitting, Tee (1/8 NPTF)
3	48011-75	1	Valve, Relief (Set at 50/75 PSI)
4	21278	1	Valve, Relief (Set at 10,100/10,700 PSI)
5	59071	1	Body, Valve
6	10425	1	Spring (.37 OD x .75 x .03 WS)
7	10261	1	Washer, Copper (.75 x .60)
8	20770	1	Fitting, Connector (9/16 x 5/8; Torque to 45 ft. lbs. oiled)
9	252494	1	Tube, Oil Line
10	20771	1	Poppet
11	350304	1	Filter

Item No.	Part No.	No. Req'd	Description
12	350995	1	Clamp, Hose
13	252986	6	Fitting, Straight (1/8 NPTF)
14	206324	2	Fitting, Straight (1/4 NPTF)
15	215952	4	Screw, Hex Washer Hd (10-24 x 5/8)
16	252483	2	Fitting, Straight (1/4 NPTF; Torque locking nut to 225 in. lbs.)
17	16177	1	Fitting, Elbow (90 deg. 1/8 NPTF)
18	10266	1	O-ring (.37 x .25 Nitrile)
19	252482	2	Screw, Soc Hd (1/4-28 x 1-1/4)
20	252429	1	Seal, Oil (.881 x .438 Nitrile)

GENERAL PUMP SECTION ASSEMBLY

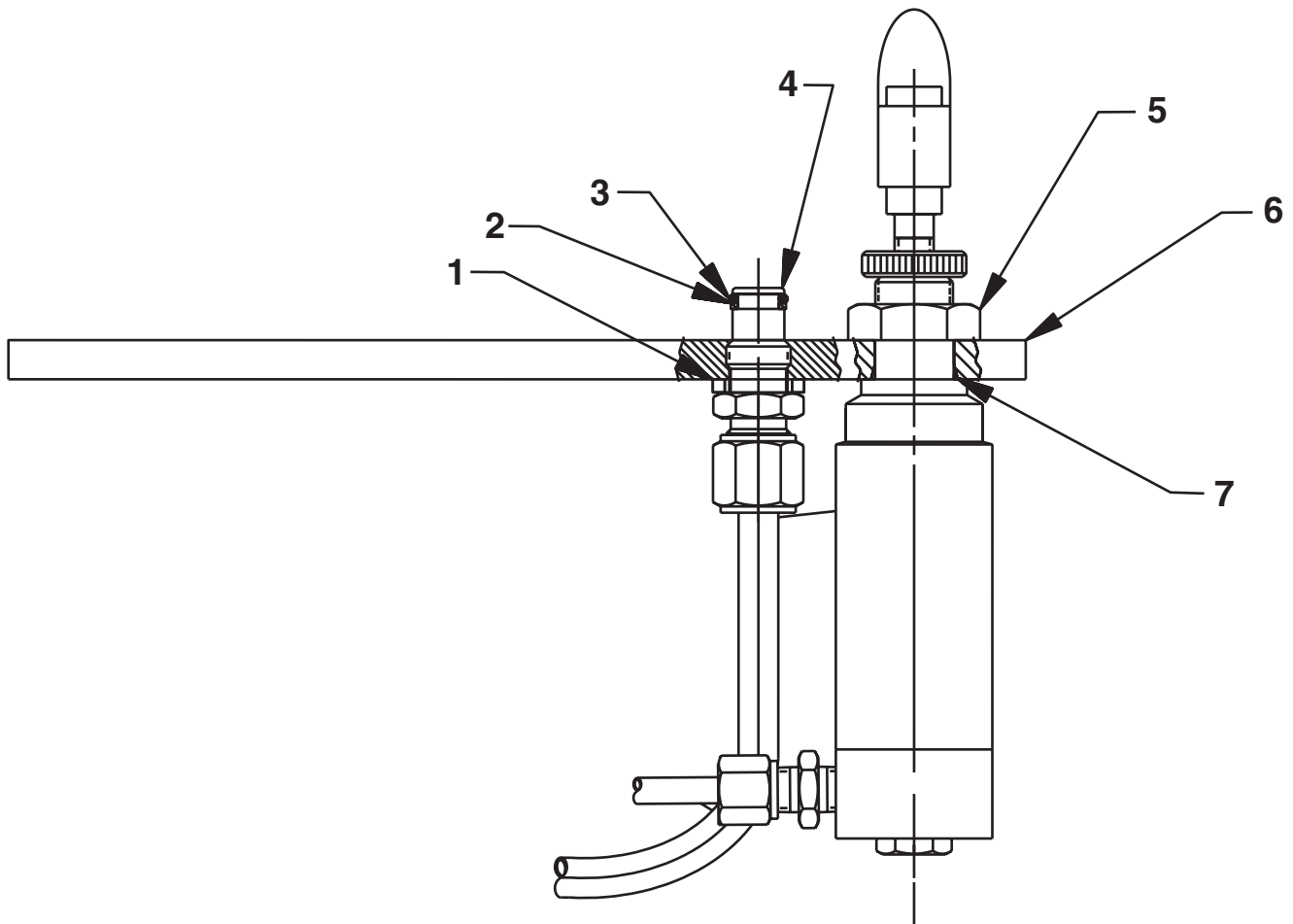

Item No.	Part No.	No. Req'd	Description
1	21484	1	Spacer
2	11863	1	Backup Washer (1/2 X 3/8 X 1/16)
3	10268	1	O-ring (1/2 X 3/8 X 1/16)
4	20787	1	Valve Connector
5	421429	1	Pressure Regulator Assembly (See sheet 6 of 7)
6	65800	1	Cover Plate
7	10527	1	O-ring (.81 x .64 Nitrile)

GENERAL PUMP - BOTTOM VIEW

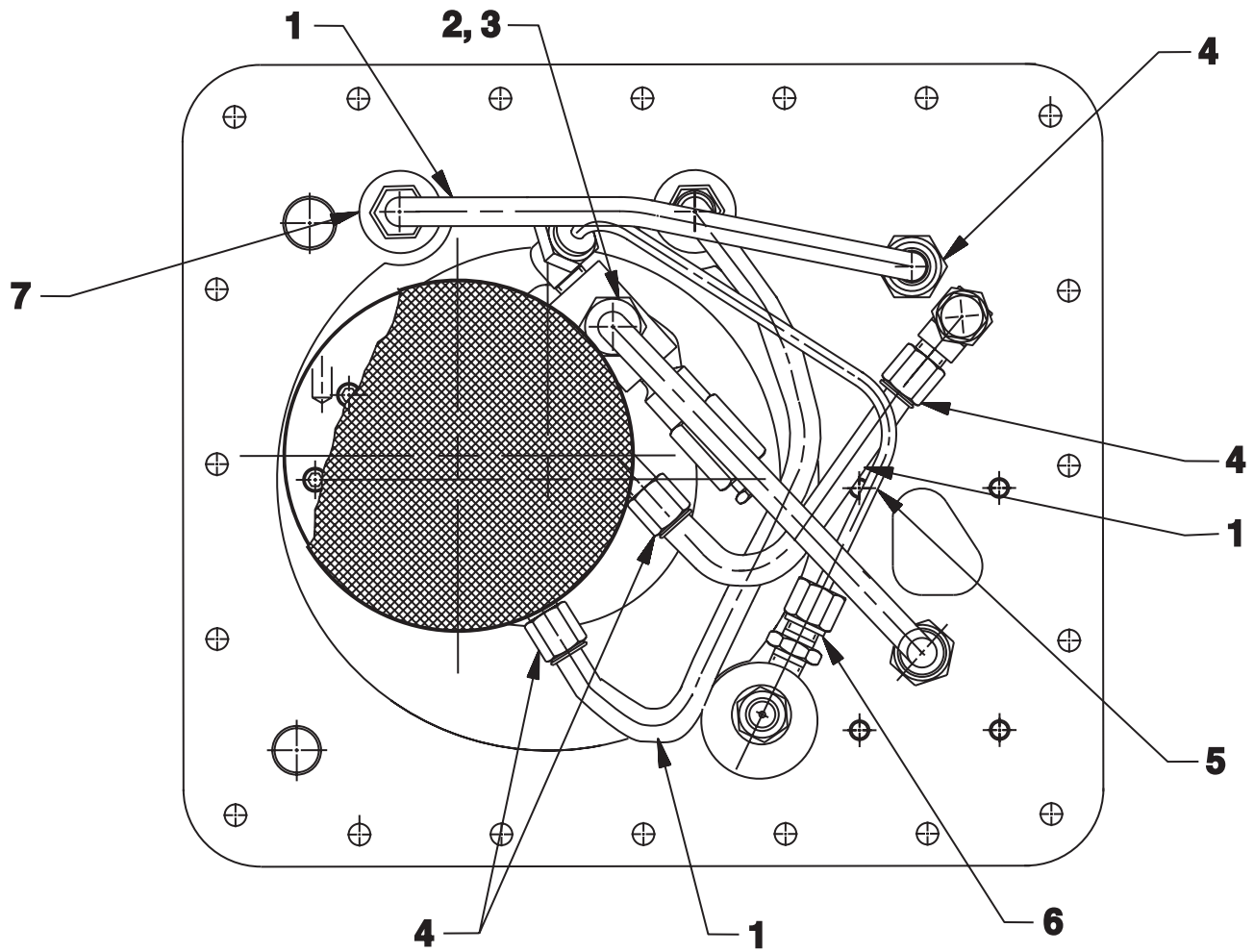

Item No.	Part No.	No. Req'd	Description
1	252226	3 ft.	Nylon Tubing
2	10430	2	Tube Sleeve
3	10431	2	Tube Nut Fitting
4	252986	4	Straight Fitting (1/8 NPTF)
5	252493	1	Oil Line Tube
6	14844	1	Straight Fitting
7	253143	2	Seal Washer

BASIC PUMP ASSEMBLY

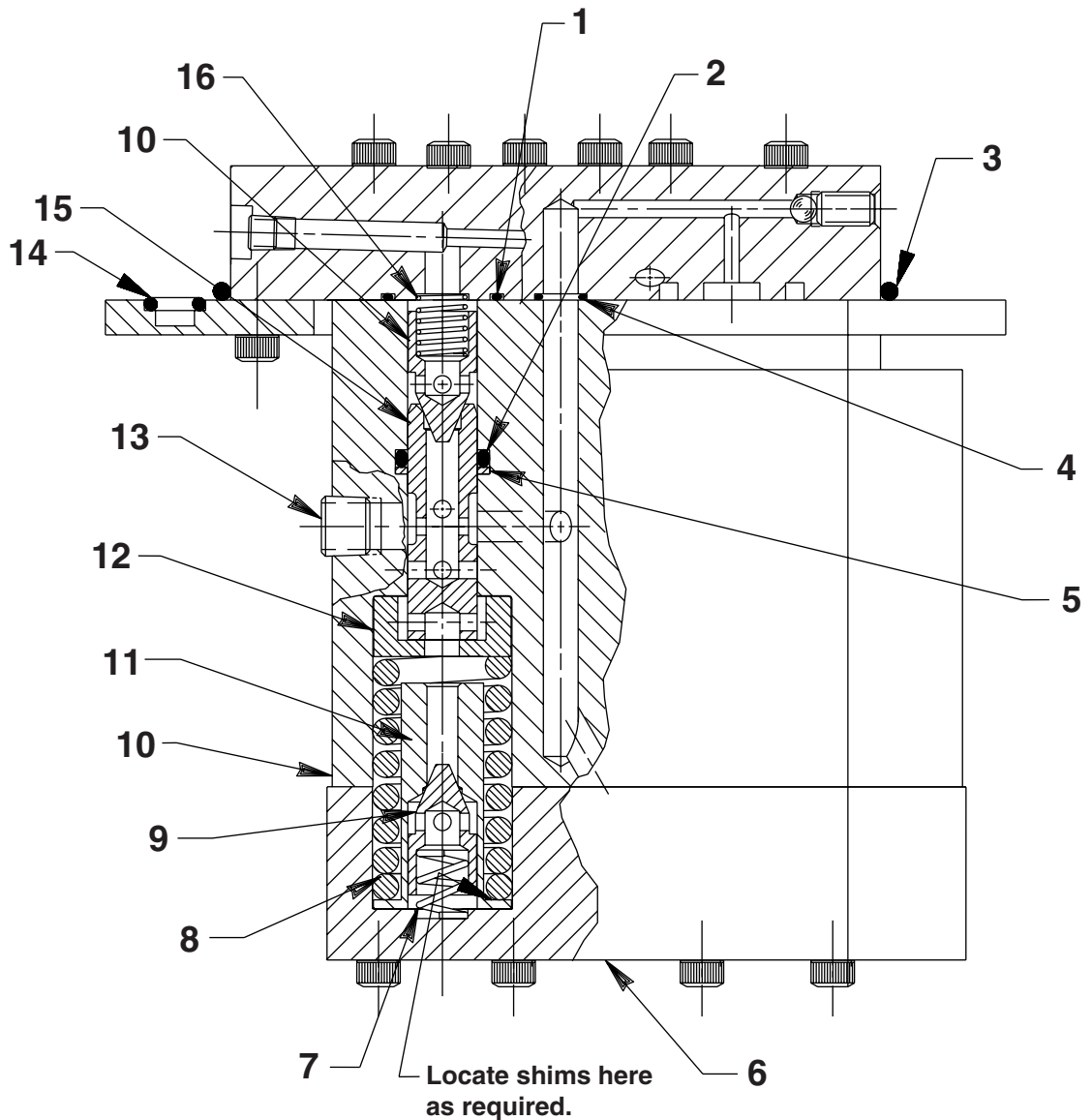

Item No.	Part No.	No. Req'd	Description
1	10303	1	O-ring (7/8 x 3/4 x 1/16)
2	10271	1	O-ring (11/16 x 1/2 x 3/32)
3	253145	1	O-ring (5.187 x 5 Nitrile)
4	10266	1	O-ring (3/8 x 1/4 x 1/16)
5	12389	1	Backup Washer (11/16 x 1/2 x 1/16)
6	65417	1	End Plate
7	250228	1	Spring (.36 O.D. x 1" x .03 WS)
8	10426	1	Compression Spring (1" O.D. x 1-13/16 Lg.)

Item No.	Part No.	No. Req'd	Description
9	20771	2	Poppet
10	65790	1	Pump Body
11	253299	1	Spacer
12	23255	1	Spring Guide
13	10427	1	Plug Fitting
14	253144	4	O-ring (.437 x .250 Nitrile)
15	20849	1	Spool
16	10425	1	Compression Spring (3/8 O.D. X 3/4 Lg.)

BASIC PUMP SUB-ASSEMBLY

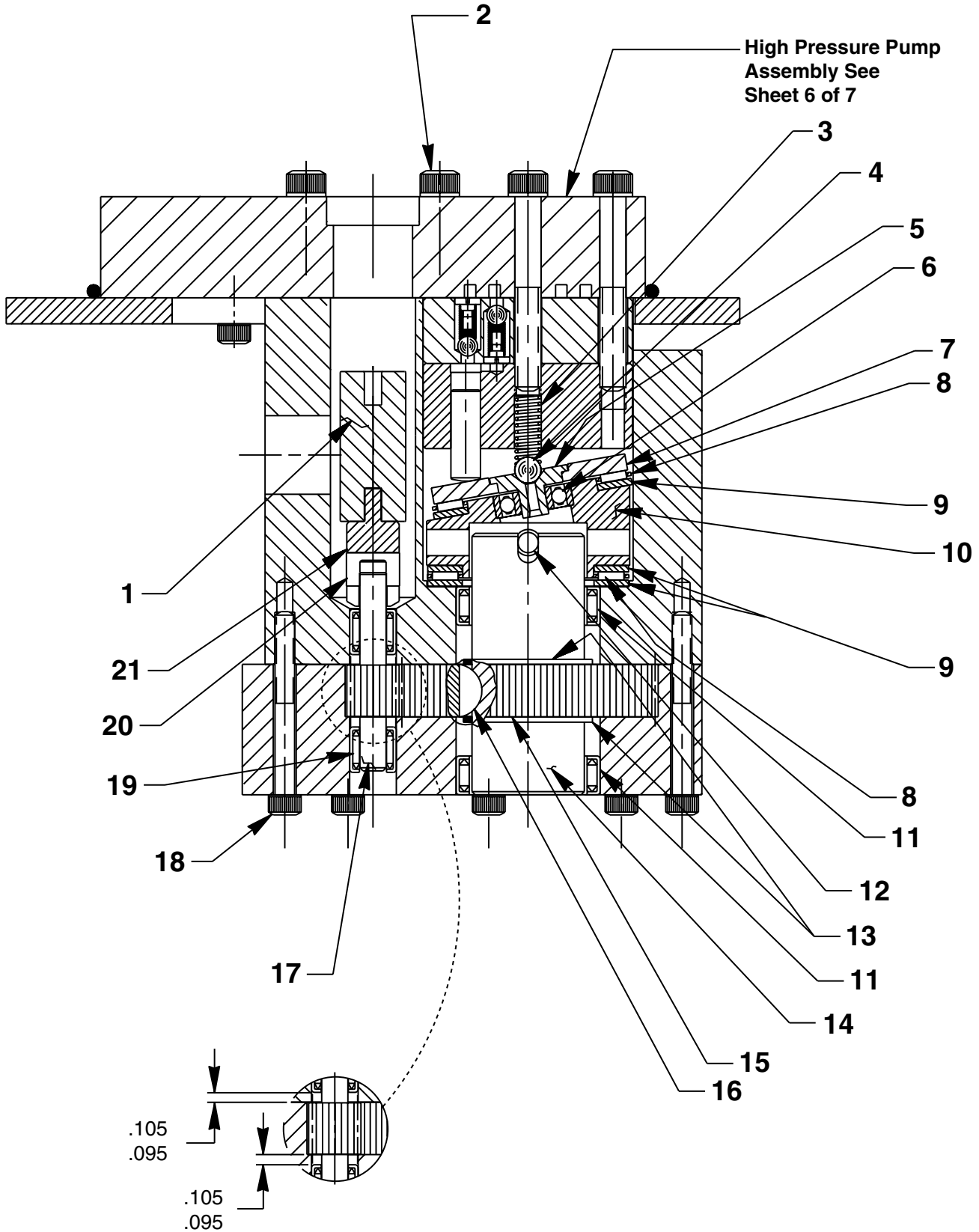

Item No.	Part No.	No. Req'd	Description
1	21091	1	Coupling
2	10022	9	Screw (1/4-20 UNC X 1-1/2 Lg.; Torque to 170/180 in. lbs.)
3	10361	1	Compression Spring (1/4 O.D. X 1" Lg.)
4	10375	1	Ball (1/4 Dia.)
5	23547	1	Bearing Top Plate
6	11814	1	Ball Bearing
7	23548	1	Top Plate
8	11228	2	Needle Bearing
9	11227	3	Bearing Race
10	351004	1	Angle Plate

Item No.	Part No.	No. Req'd	Description
11	11064	2	Needle Bearing
12	11955	1	Slotted Spring Pin
13	11261	2	Retaining Ring
14	23556	1	Shaft
15	23574	1	Drive Gear
16	11821	1	Woodruff Key
17	20774	1	Drive Gear
18	10001	13	Screw (#10-32 UNF X 1-3/4 Lg.; Torque to 50/60 in. lbs.)
19	11198	2	Needle Bearing
20	21093	1	Key
21	351643	1	Adapter

PRESSURE REGULATOR ASSEMBLY

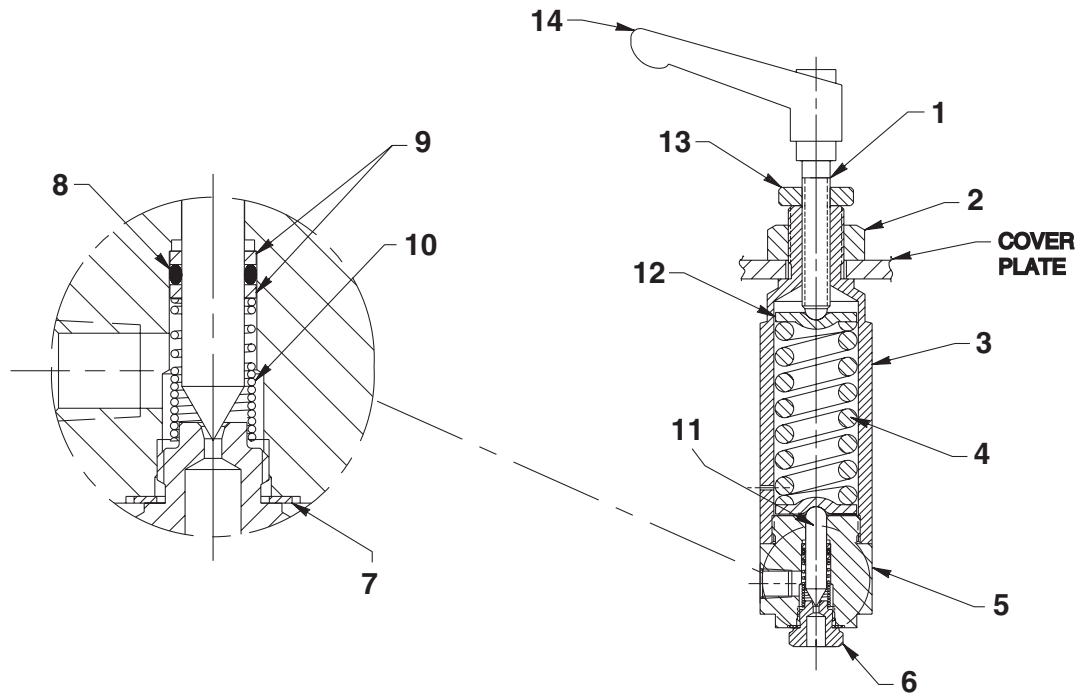

Item No.	Part No.	No. Req'd	Description
1	252427	1	Adjustment Stem (Note: Assemble to handle with Loctite 242 or equiv.)
2	10396	1	Jam Nut
3	351350	1	Regulator Housing
4	215429	1	Compression Spring (1.100 O.D. X 2-1/2 Lg.)
5	420891	1	Regulator Body
6	351343	1	Seat Fitting (Torque to 440/460 in. lbs.)
7	14874	1	Copper Washer (.700 X 1/2 X 1/32)

Item No.	Part No.	No. Req'd	Description
8	10266	1	O-ring (3/8 X 1/4 X 1/16)
9	215430	2	Backup Washer (.385 x .282 x .050)
10	215431	1	Spring (3/8 O.D. x 2 1/32 Lg.; Note: Assemble closed coils of spring form towards seat fitting [Item#6])
11	309079	1	Poppet
12	215428	2	Spring Retainer (Grease pocket before assembling [both ends])
13	215683	1	Regulator Locking Nut
14	252332	1	Adjustable Handle

HIGH PRESSURE PUMP ASSEMBLY

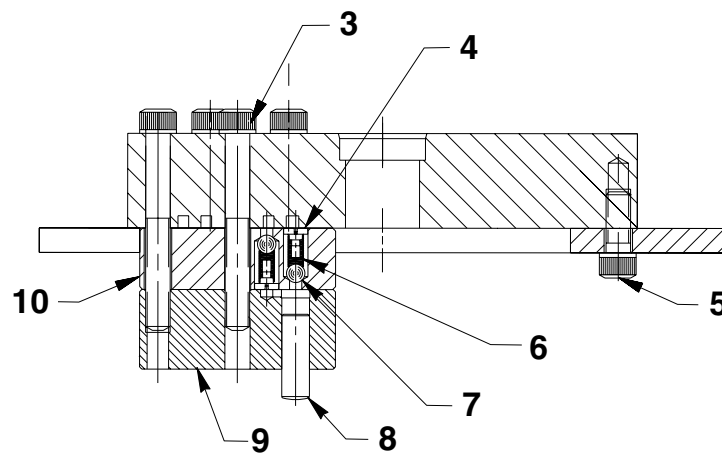
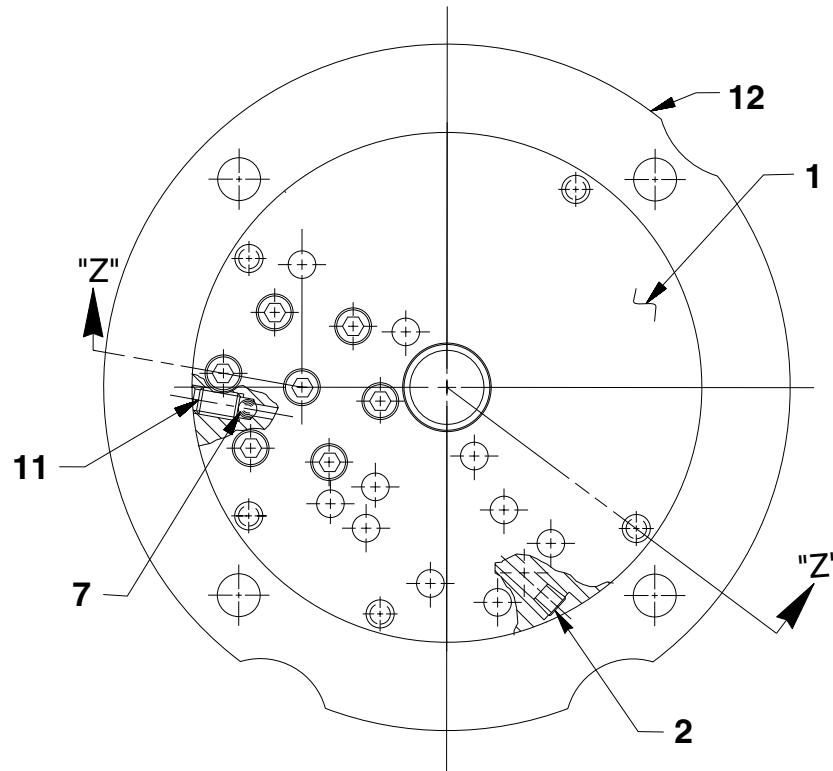

SECTION "Z-Z"

Item No.	Part No.	No. Req'd	Description
1	65789	1	Top Plate
2	15130	1	Plug Fitting (Apply thread tape and torque to 130/150 in. lbs.)
3	15318	7	Soc. Hd. Screw (1/4-28 x 2; Torque to 175 in. lbs.)
4	24549	6	Ball Guide
5	10006	5	Soc. Hd Screw (1/4-20 x 5/8)
6	10445	6	Compression Spring (5/32 O.D. X 3/4" Lg.)
7	12223	7	Steel Ball (3/16" Dia.)
8	21628	3	Piston
9	41062	1	Pump Barrel
10	421473	1	Valve Head
11	10519	1	Soc. Set Screw (1/4-20 UNC X 3/8 Lg.; Torque to 65/70 in. lbs.)
12	59070	1	Flange Plate

MOTOR CONTROL ASSEMBLY

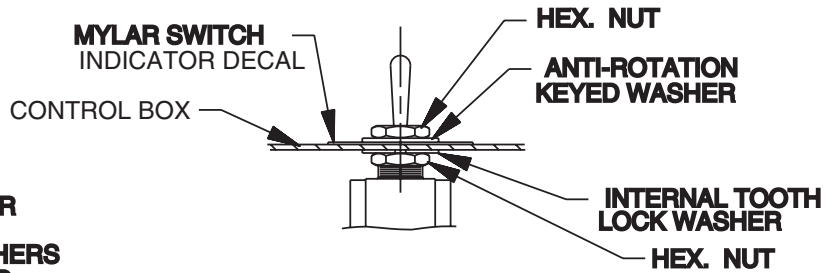
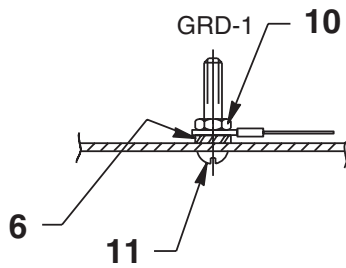
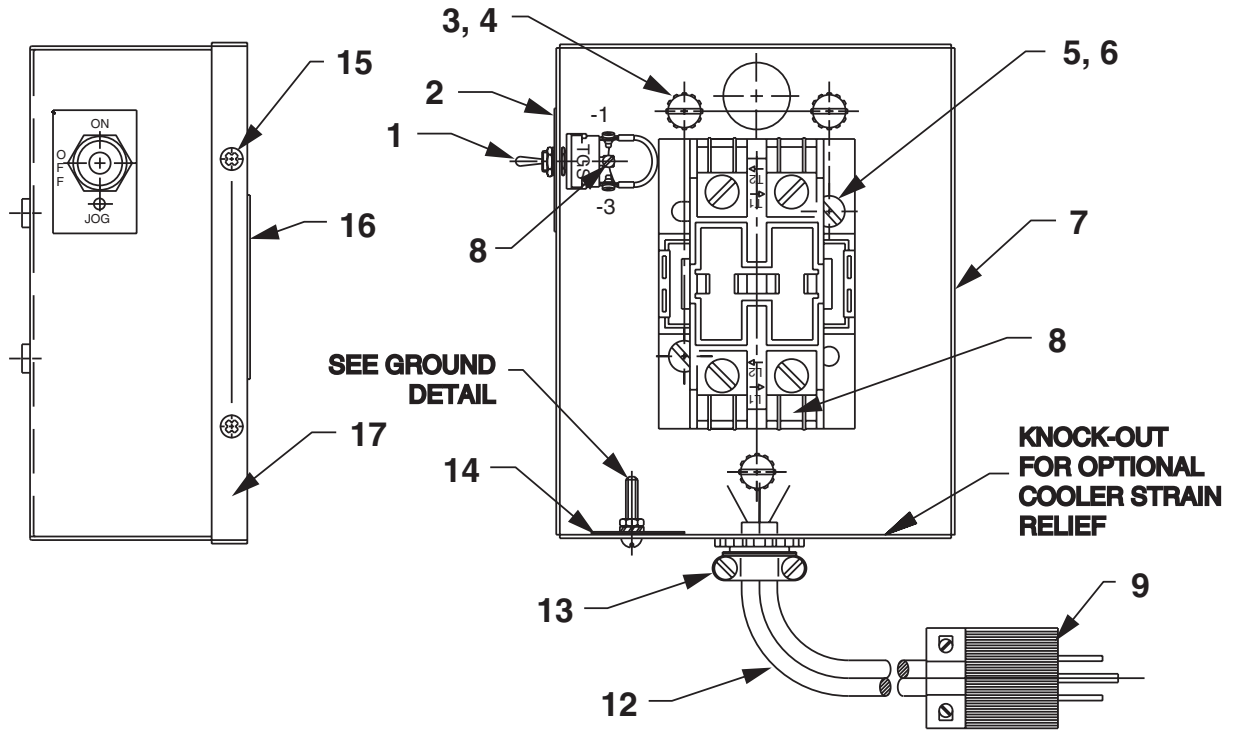

NOTE: SERRATED LOCK WASHER MUST BE ADJACENT TO METAL BOX. MORE WASHERS CAN BE USED IF DESIRED.

GROUND DETAIL

Item No.	Part No.	No. Req'd	Description
1	12175	1	Switch (On/Off/Momentary)
2	203912	1	Decal (On/Off/Jog)
3	10447	3	Screw, Round Hd (8-32 x 5/16)
4	11388	3	Washer, Tooth Ext (.37 x .17)
5	11539	2	Screw, Round Hd (10-24 x 1/4)
6	11108	3	Washer, Tooth Ext (.40 x .20)
7	421640WH2	1	Box, Electrical Control
8	420718-1	1	Contactactor (110/115 V, 50/60 HZ)
	420718-2	1	Contactactor (220/230 V, 50/60 HZ)
9	16896	1	Plug, Electrical (110/115 V. only)
10	10197	1	Nut, Hex (10-24)

Item No.	Part No.	No. Req'd	Description
11	10167	1	Screw, Round Hd (10-24 x 3/4)
12	307439	1 ft.	Cable (12/3 SJTO, 110/115 V. 50/60 HZ)
	308752	1 ft.	Cable (14/3 SJTO, 220/230 V, 50/60 HZ)
13	11203	1	Connector, Conduit
14	205189	1	Decal, Label Ground
15	11141	4	Screw, Pan Hd (6-20 x 3/8)
16	200188	1	Decal, Warning Important
17	421641WH2	1	Cover, Control Box

ELECTRICAL SCHEMATIC
115/220 V., 50/60 Hz. Single Phase

