

MODEL B
DOUBLE-ACTING, HOLLOW CENTER
HYDRAULIC CYLINDER

Max. Capacity: 150.9 Tons at 10,000 PSI (Push)
73.6 Tons at 10,000 PSI (Pull)

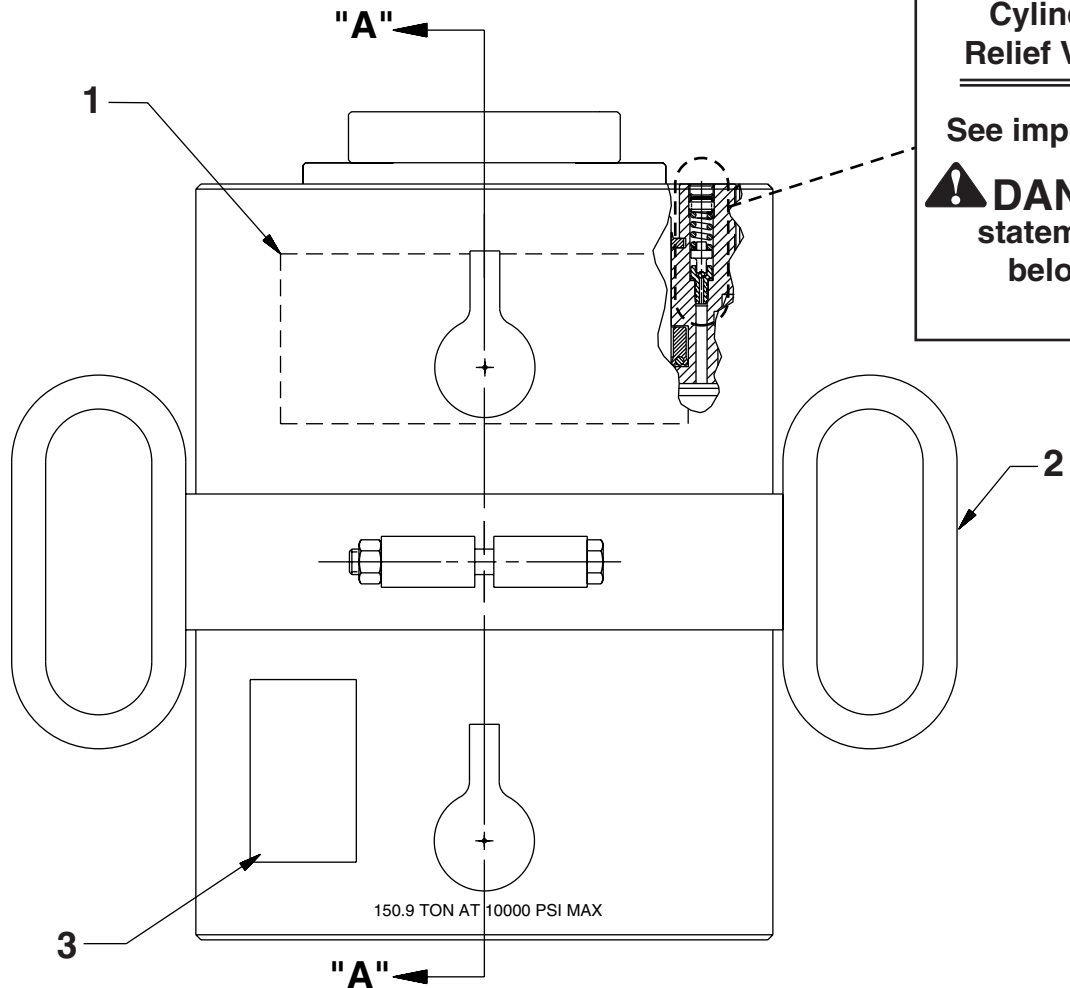

**Double-acting
Cylinder
Relief Valve**
See important
DANGER
statement
below



DANGER: To help avoid possible serious personal injury or death,

- In the event that the cylinder retract port is ever restricted or plugged, a double-acting cylinder relief valve will help prevent excessive pressure from building in the cylinder. **DO NOT** attempt to adjust or service this relief valve! If oil leakage is detected from this relief valve, discontinue use of the cylinder immediately and contact Power Team Technical Services. Only Power Team Authorized Hydraulic Service Centers should service this relief valve.

Item No.	Part No.	No. Req'd	Description
1	351859	1	Decal, Tradename (Power Team)
2	59234OR9	1	Handle, Cylinder Lift
3	203908	1	Decal, Warning

Sheet No. 1 of 1

Rev. 2 Date: 22 Mar. 1999

SECTION A-A

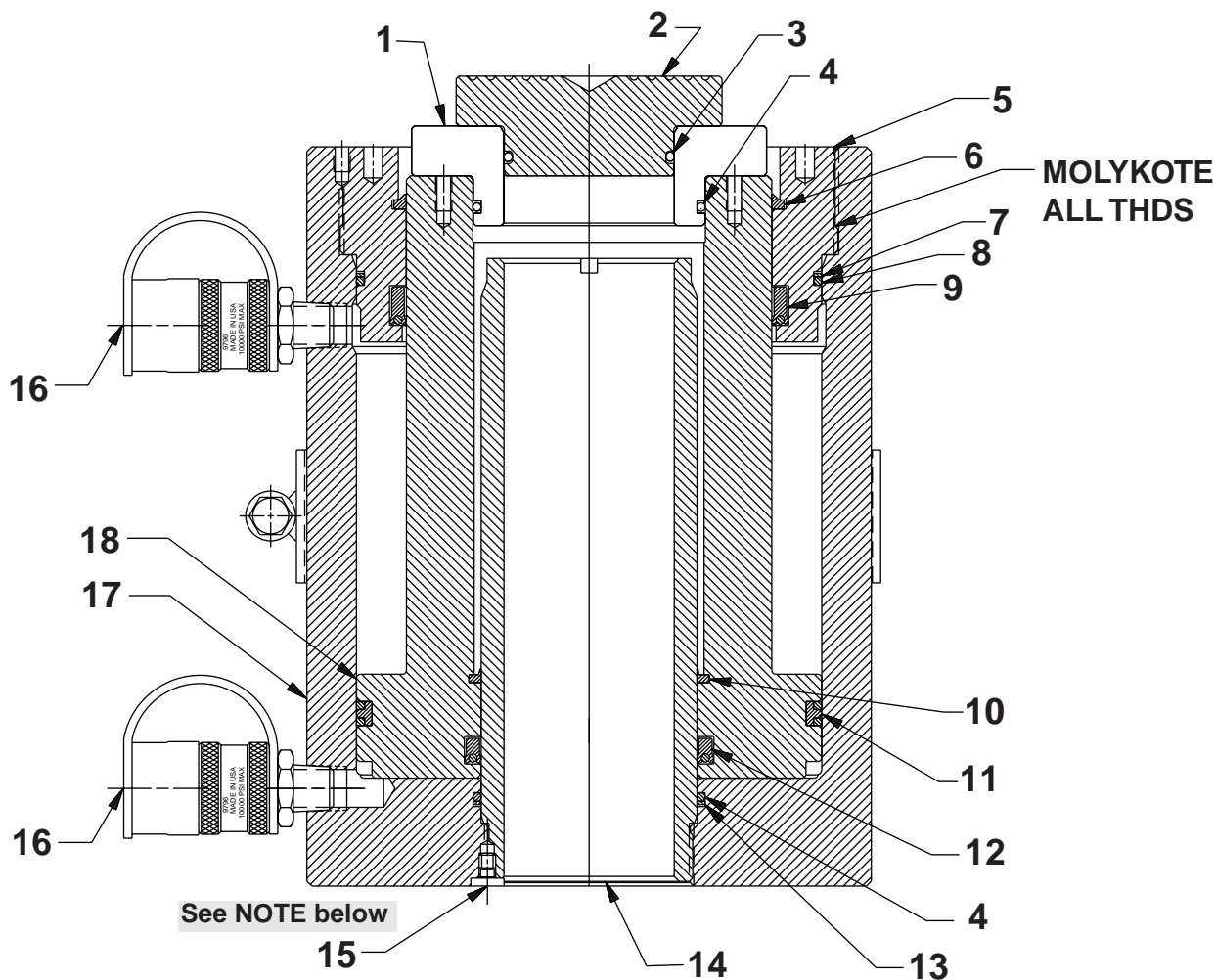

Item No.	Part No.	No. Req'd	Description
1	37287	1	Insert, Plain
2	37288	1	Insert, Serrated
3	*10295	1	O-ring (2.50 x 2.25 Nitrile)
4	*10297	2	O-ring (3.50 x 3.25 Nitrile)
5	51043	1	Nut, Retainer (10-32)
6	*207593	1	Wiper, Rod (5.94 x 5.50 URE)
7	*†19176	1	Washer, Backup (7.00 x 6.75)
8	*16317	1	O-ring (7.00 x 6.75 Nitrile)
9	*16315	1	U-cup (6.00 x 5.50 x .56 H)
10	*16311	1	Wiper, Rod (3.63 x 3.25 URE)

Item No.	Part No.	No. Req'd	Description
11	*16313	1	T-seal (7.00 x 6.50 x .36 L)
12	*16316	1	U-cup (3.75 x 3.25 x .38 H)
13	*†19166	1	Washer, Backup (3.50 x 3.25)
14	36406	1	Pipe, Stand (Bottom out and back off 1/8 revolution before adding set screw; Molykote all thds.)
15	10556	1	Screw, Set (1/4-20 x 1/4; See NOTE below)
16	9796	2	Coupler, Quick Cylinder Half
17	65995	1	Body, Cylinder
18	51044	1	Piston

Part numbers marked with an asterisk (*) are contained in Repair Kit No. 300154.
 Part numbers marked with a dagger (†) are contained in Viton Seal Kit No. 300228.

NOTE: Cylinders built after 1-1-99 do not use this set screw to lock the standpipe and cylinder body together. Loctite 242 is used on last 2-3 standpipe threads only!

Note: Shaded areas reflect last revision(s) made to this form.

Refer to any operating instructions included with this product for detailed information about operation, testing, disassembly, reassembly, and preventive maintenance.

Items found in this parts list have been carefully tested and selected. **Therefore: Use only genuine Power Team replacement parts!**

Additional questions can be directed to our Technical Services Department.