

**MODEL C**  
**IN-LINE HYDRAULIC FLOW TESTER**  
 200 GPM, 750 l/min.

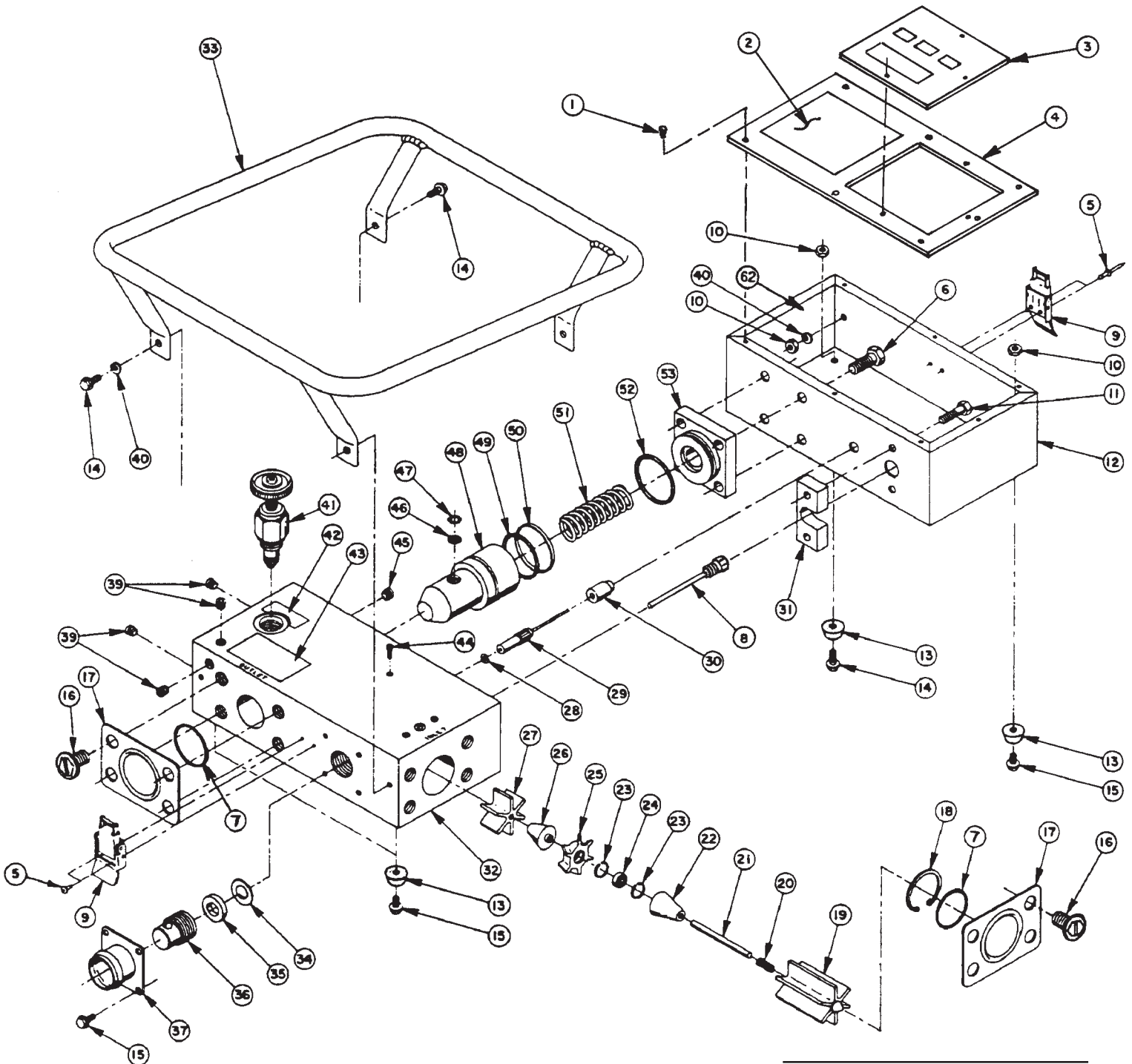

# Parts List, Form No. 108094, Back sheet 1 of 2

Item No.	Part No.	No. Req'd	Description
1	16972	10	Self-Tapping Screw (#4-24 X 1/4 Lg.)
2	352059	1	Trade Name Decal
3	352004	1	Display Circuit Board (See Detail below)
4	421922	1	Plate
5	16417	4	Pop Rivet
6	16932	4	Hex Hd. Cap Screw (3/8-16 X 1" Lg.; Torque to 31/41 ft. lbs.)
7	11303	2	O-ring (1-7/8 X 1-11/16 X 3/32)
8	16445	1	Thermistor Probe
9	16416	2	Catch
10	10197	4	Hex Nut (#10-24 UNC)
11	10017	2	Hex Hd. Cap Screw (1/4-20 UNC X 1" Lg.; Torque to 80/85 in. lbs.)
12	51086BK2	1	Electronic Box
13	16429	4	Recessed Bumper
14	16467	5	Hex Hd. Cap Screw (#10-24 X 1/2 Lg.)
15	15415	4	Hex Hd. Cap Screw (#10-24 X 3/8 Lg.; Torque to 20/25 in. lbs.)
16	16444	8	Button Plug (1/2 - 13UNC)
17	16443	2	Flange Cap
18	10712	1	Retaining Ring (for 1-1/2 hole)
19	36523	1	Flow Straightener (long)
20	16462	1	Compression Spring (1/4 O.D. X 3/8 Lg.)
21	24758	1	Locating Pin
22	202032	2	Cone (long)
23	16455	2	Retaining Ring (for 1/2 hole)
24	16454	1	Ball Bearing
25	202036	1	Turbine Rotor
26	202031	1	Cone (short)
27	36522	1	Flow Straightener (short)
28	†207339	1	Nylon Washer (.020 thk.)

Item No.	Part No.	No. Req'd	Description
29	†302827	1	Magnetic Pickup
30	202128	1	Guide Spacer
31	202030	1	Spacer
32	60343	1	Flow Block
33	50955BK2	1	Wrap Around Bar Ass'y
34	16542	1	Rupture Disc
35	16541	1	Hold Down Ring
36	36621	1	Burst Disc Retainer (Torque to 100/110 ft. lbs.)
37	202166BK2	1	Hose Connector
39	251222	4	Pipe Plug (1/16 NPTF)
40	10241	4	Lockwasher (for #10 bolt)
41	16882	1	Cartridge Relief Valve (See back sheet 2 of 2)
42	*202076	1	Decal (Increase/Decrease)
43	16678	1	Warning Decal
44	17458	1	Soc. Hd. Cap Screw (#4-40 X 3/8 Lg.; Torque to 4/6 in. lbs.)
45	15499	1	Pipe Plug (1/8 NPTF)
46	207166	1	Filter Disk
47	11893	1	Retaining Ring (for 7/16" hole)
48	36520	1	Poppet Filter Assembly (includes Items 46 & 47)
49	*14739	1	O-ring (1-11/16 X 1-1/2 X 3/32)
50	*16447	1	Glyd Ring
51	16969	1	Compression spring (.970 O.D. X 3" Lg.)
52	*16418	1	Disogrin O-ring (1-7/8 X 1-11/16 X 3/32)
53	36521	1	End Cap

### PARTS INCLUDED BUT NOT SHOWN

352050 1 Warning Decal (Inside cover)

**NOTE: See back sheet 2 of 2 for cover assembly.**

Part numbers marked with an asterisk (\*) are contained in Repair Kit #300310.

†Must be ordered as a set.

## DETAIL OF BOTTOM VIEW OF DISPLAY CIRCUIT BOARD

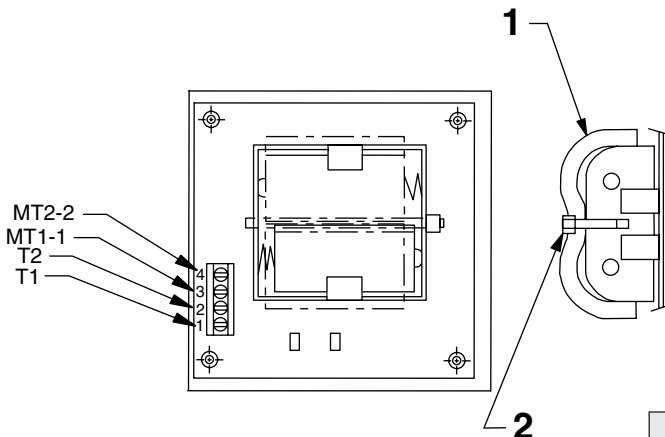

Item No.	Part No.	No. Req'd	Description
1	5-3571	1	Foam Tape (Cut to 3.500/3.750 in.)
2	250713	1	Cable Tie (Foam tape [Item #1] may separate. Assemble cable tie as shown, through battery holder, with connection to side and clip excess.)

Note: Added this Detail at last revision(s) made to this form.

### DUAL PRESSURE GAUGE ASSEMBLY

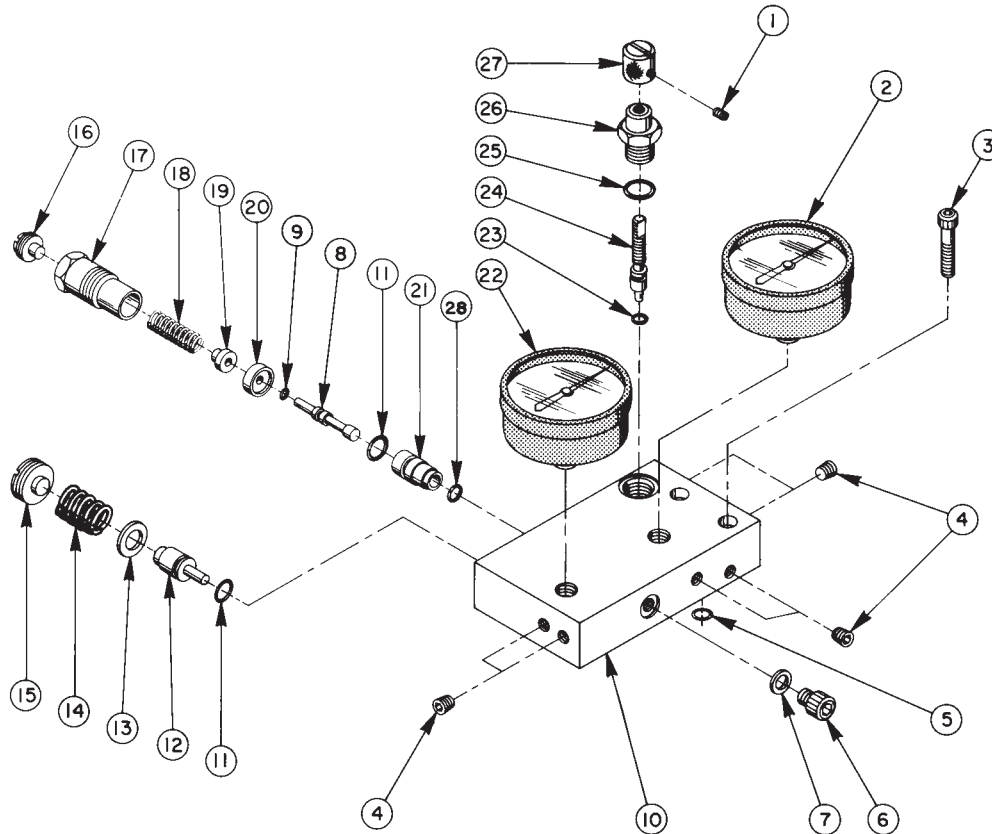

Item No.	Part No.	No. Req'd	Description	Item No.	Part No.	No. Req'd	Description
1	10132	1	Set Screw (#8-32 UNC X 1/4)	15	200020	1	Plug
2	11637	1	High Pressure Gauge	16	27850	1	Adjusting Screw
	17967	1	Liquid-Filled Gauge (0-6000 PSI; optional)	17	33414	1	Spring Retainer
3	10020	2	Soc. Hd. Cap Screw (1/4-20 UNC X 1-1/4 Lg.)	18	13165	1	Compression Spring (3/8 O.D. X 1-1/2 Lg.)
4	11084	6	Pipe Plug (1/16 NPTF)	19	27805	1	Spring Button
5	*10266	1	O-ring (3/8 X 1/4 X 1/16)	20	27806	1	Guide Collar
6	25683	1	Special Cap Screw	21	27783	1	Guide
7	*11031	1	Copper Washer (15/32 X 5/16 X 1/32)	22	11636	1	Low Pressure Gauge
8	27786	1	Spool (See Form #102461 for correct installation)	22	17966	1	Liquid-Filled Gauge (0-600 PSI; optional)
9	*10264	1	O-ring (1/4 X 1/8 X 1/16)	23	*10265	1	O-ring (5/16 X 3/16 X 1/16)
10	50445	1	Dual Gauge Block	24	200686	1	Stem
11	*10268	2	O-ring (1/2 X 3/8 X 1/16)	25	*10300	1	O-ring (5/8 X 15/32 X 5/64)
12	200021	1	Plunger (See Form #102461 for correct installation)	26	33415	1	Guide
13	14968	1	Washer (3/4 X 25/64 X 1/16)	27	200685	1	Knob
14	14979	1	Compression Spring (3/4 O.D. X 1" Lg.)	28	*12522	1	O-ring (3/8 X 1/4 X 1/16)
					33422	1	Dual Gauge Ass'y (consists of Items 1-28)

Part numbers marked with an asterisk (\*) are contained in Repair #300310.

### COVER ASSEMBLY

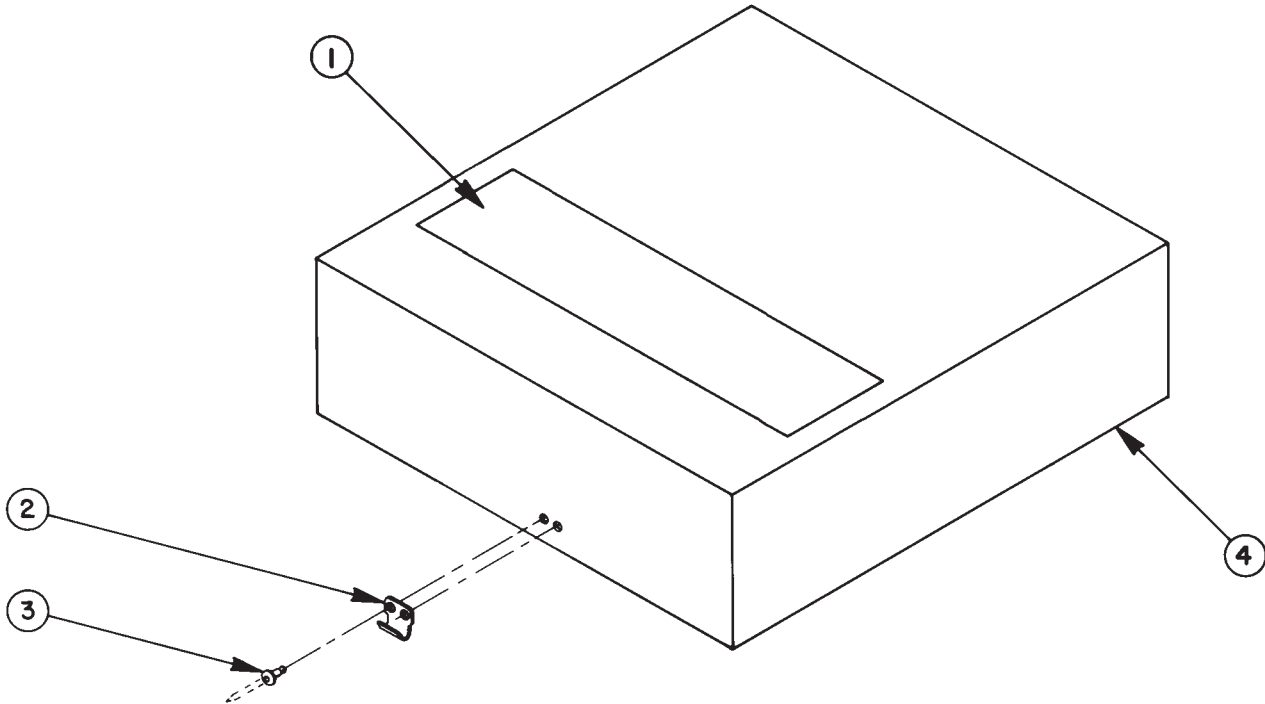

Item No.	Part No.	No. Req'd	Description
1	309219	1	Trade Name Decal
2	16979	2	Catch
3	16417	4	Pop Rivet
4	66272	1	Cover Assembly (Consists of Items 2-4; Painted white)

### CARTRIDGE RELIEF VALVE ASSEMBLY

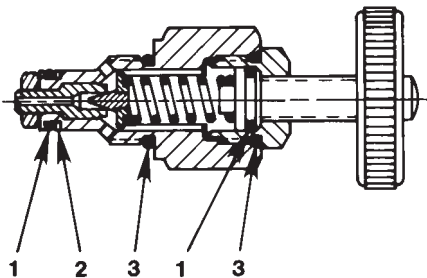

Item No.	Part No.	No. Req'd	Description
1	*10268	2	O-ring (1/2 X 3/8 X 1/16)
2	*11863	1	Backup Washer (1/2 X 3/8 X 1/16)
3	*10527	2	O-ring (13/16 X .644 X .087)

Part numbers marked with an asterisk (\*) are contained in Repair Kit #300310.

Refer to any operating instructions included with this product for detailed information about operation, testing, disassembly, reassembly, and preventive maintenance.

Items found in this parts list have been carefully tested and selected. **Therefore: Use only genuine Power Team replacement parts!**

Additional questions can be directed to our Technical Services Department.