

Parts List for:

PA46A Series
PA462
PA464
PA464-5R

MODEL B
AIR HYDRAULIC PUMP

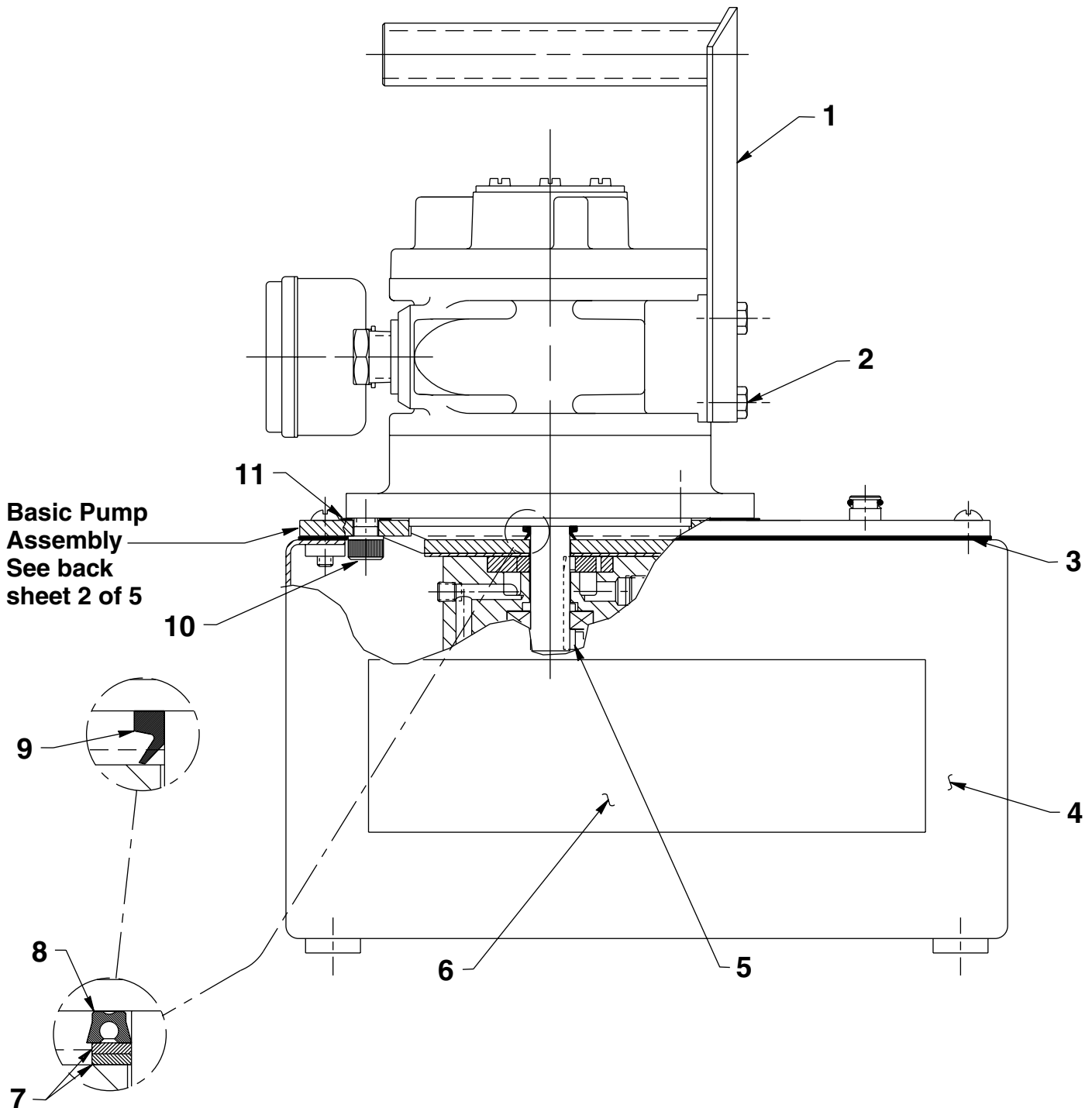

Item No.	Part No.	No. Req'd	Description
1	422102BK2	1	Handle Weldment
2	10005	4	Cap Screw (1/4-20 x 1/2)
3	40164	1	Gasket
4	40063OR9	1	Reservoir (For PA464 & PA462)
	40137BL2	1	Reservoir (For PA464-5R)
5	214097	1	Key
6	309219	2	Trade Name Decal (For PA464 & PA462)
7	251498	1	Backup Washer (.88 x .63; Use with EPR u-cup [Item #8].)
8	251291	1	U-cup (EPR)
9	213674	1	V-ring (Nitrile)
	215438	1	V-ring (Viton)
10	15187	4	Soc. Hd. Cap Screw (3/8-16 UNC X 5/8 Lg.; Torque to 90/100 in. lbs.)
	10464	4	Soc. Hd. Cap Screw (3/8-16 UNC X 3/4 Lg.; Torque to 90/100 in. lbs.) (For PA462 and PA464 Only)
11	307425	1	Motor Base Gasket

**PARTS INCLUDED BUT NOT SHOWN
FOR PUMP PA464-5R**

306051	1	Extension Intake Tube
40194BK2	1	Cover Plate Adapter
40490	1	Gasket
10177	10	Machine Screw (1/4-20 UNC X 3/4 Lg.)

Refer to any operating instructions included with this product for detailed information about operation, testing, disassembly, reassembly, and preventive maintenance.

Items found in this parts list have been carefully tested and selected. **Therefore: Use only genuine Power Team replacement parts!**

Additional questions can be directed to our Technical Services Department.

TOP VIEW

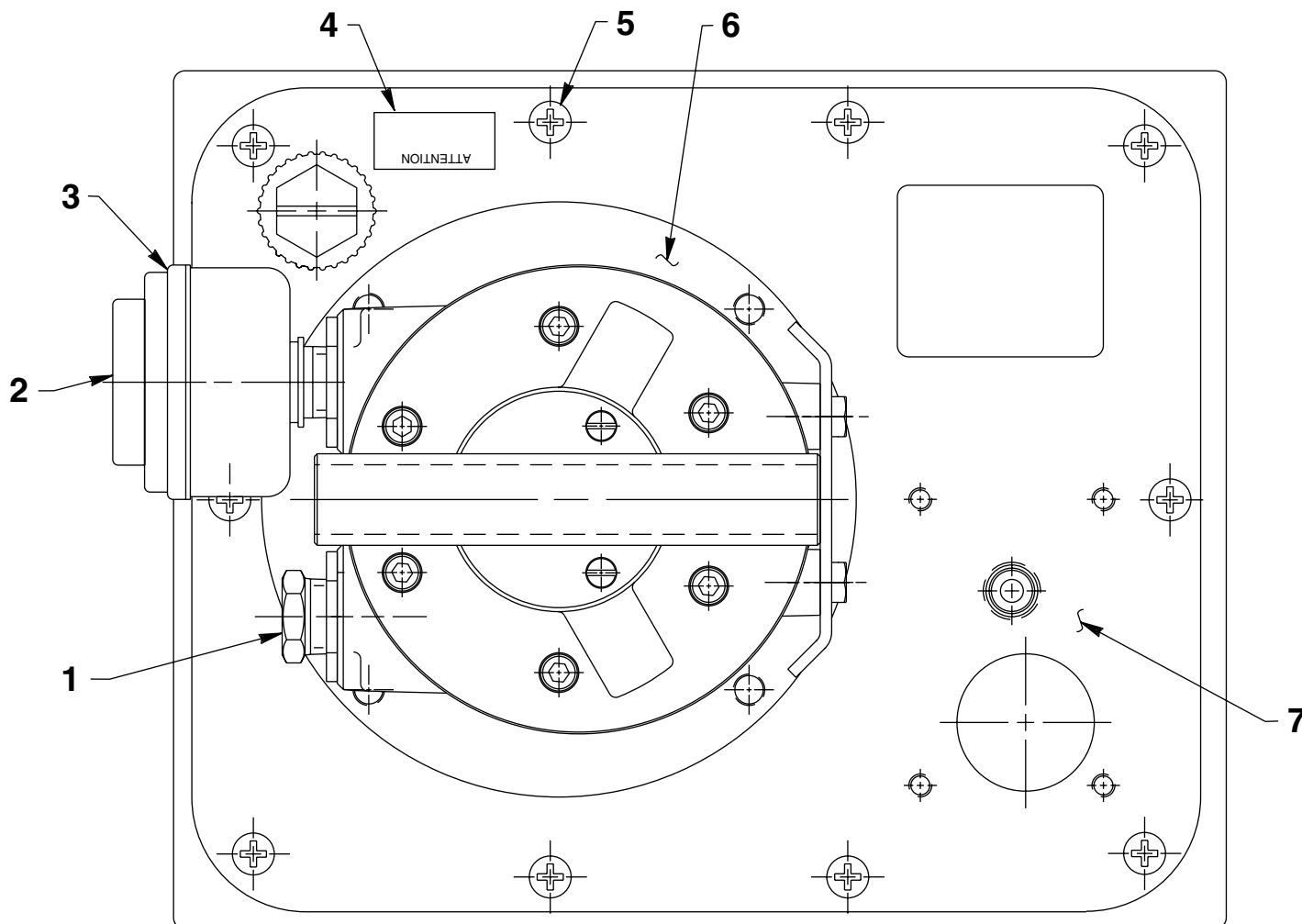

Item No.	Part No.	No. Req'd	Description
1	10677	1	Fitting
2	205505	1	Deflector (Point exhaust opening down.)
3	13966	1	Muffler
4	205724	1	Decal (For pumps with Viton seals)
	250328	1	Decal (For pumps with EPR seals)
5	10177	10	Rd. Hd. Machine Screw (1/4-20 UNC X 3/4 Lg.)
6	66483	1	Air Motor (See Form No. 108170)
7	9584	1	Valve (For PA462; See Form No. 101239; Replace current drain line tube with No. 200609 tube.)
	52510	1	Valve (For PA464 & PA464-5R; See Form No. 100623)

Item No.	Part No.	No. Req'd	Description
PARTS INCLUDED BUT NOT SHOWN			
	12328	1	Nipple (For PA462 & PA464)
	10672	1	Nipple (For PA464-5R)
	13645	1	2-Way Air Valve (For PA462 & PA464)
	211629	1	Valve (For PA464-5R)
	10014	1	Hex Hd. Cap Screw (1/4-28 UNF X 1" Lg.)

BASIC PUMP ASSEMBLY-SIDE VIEW

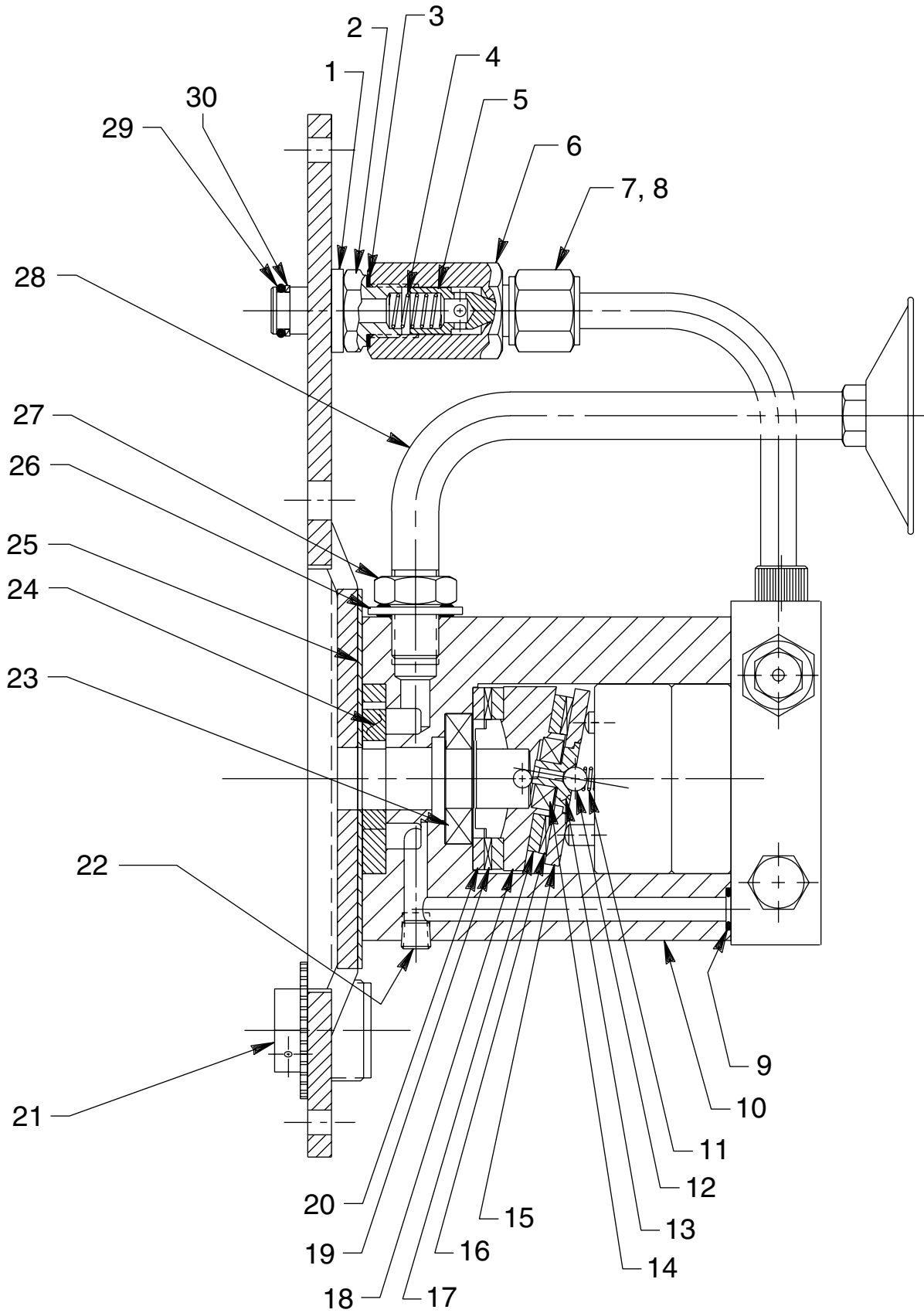

Item No.	Part No.	No. Req'd	Description
1	21484	1	Washer
2	214762	1	Valve Connector (Note: The torque between the valve connector [Item #2] and the cover plate [Item #2 on sheet 3 of 4] shall be 30 ft. lbs. max. The torque between the valve connector [Item #2] and the check valve body [Item #6] shall be 40-50 ft. lbs.)
3	10261	1	Copper Washer (3/4 X 19/32 X 1/32)
4	10425	1	Compression Spring (3/8 O.D. X 3/4 Lg.)
5	20771	1	Poppet
6	201879	1	Check Valve Body
7	10430	1	Tube Sleeve
8	10431	1	Tube Nut
9	10267	1	O-ring (7/16 X 5/16 X 1/16; Nitrile)
	18974	1	O-ring (7/16 X 5/16 X 1/16; Viton)
	13472	1	O-ring (7/16 X 5/16 X 1/16; EPR)
10	52883	1	Body Pump
11	16320	1	Compression Spring (1/4 O.D. X 3/4 Lg.)
12	10375	1	Ball (1/4 Dia.)
13	23547	1	Top Plate Bearing
14	11814	1	Ball Bearing
15	23548	1	Top Plate
16	15431	1	Needle Thrust Bearing
17	15432	1	Needle Thrust Race Bearing
18	35271	1	Angle Plate
19	11228	1	Needle Thrust Bearing
20	11227	1	Needle Thrust Race Bearing
21	213706	1	Filler Cap
22	11084	1	Pipe Plug (1/16 NPTF)
23	15695	1	Ball Bearing
24	15693	1	Gerotor Set
25	307296	1	Wear Plate
26	213709	1	Seal Washer (Nitrile)
	215633	1	Seal Washer (Viton)
	215634	1	Seal Washer (EPR)
27	10390	1	Hex Jam Nut
28	213686	1	Intake Tube
29	10268	1	O-ring (1/2 X 3/8 X 1/16; Nitrile)
	19775	1	O-ring (1/2 X 3/8 X 1/16; Viton)
	17716	1	O-ring (1/2 X 3/8 X 1/16; EPR)
30	11863	1	Teflon Backup Washer (1/2 X 3/8 X 1/16)

BASIC PUMP ASSEMBLY-BOTTOM VIEW

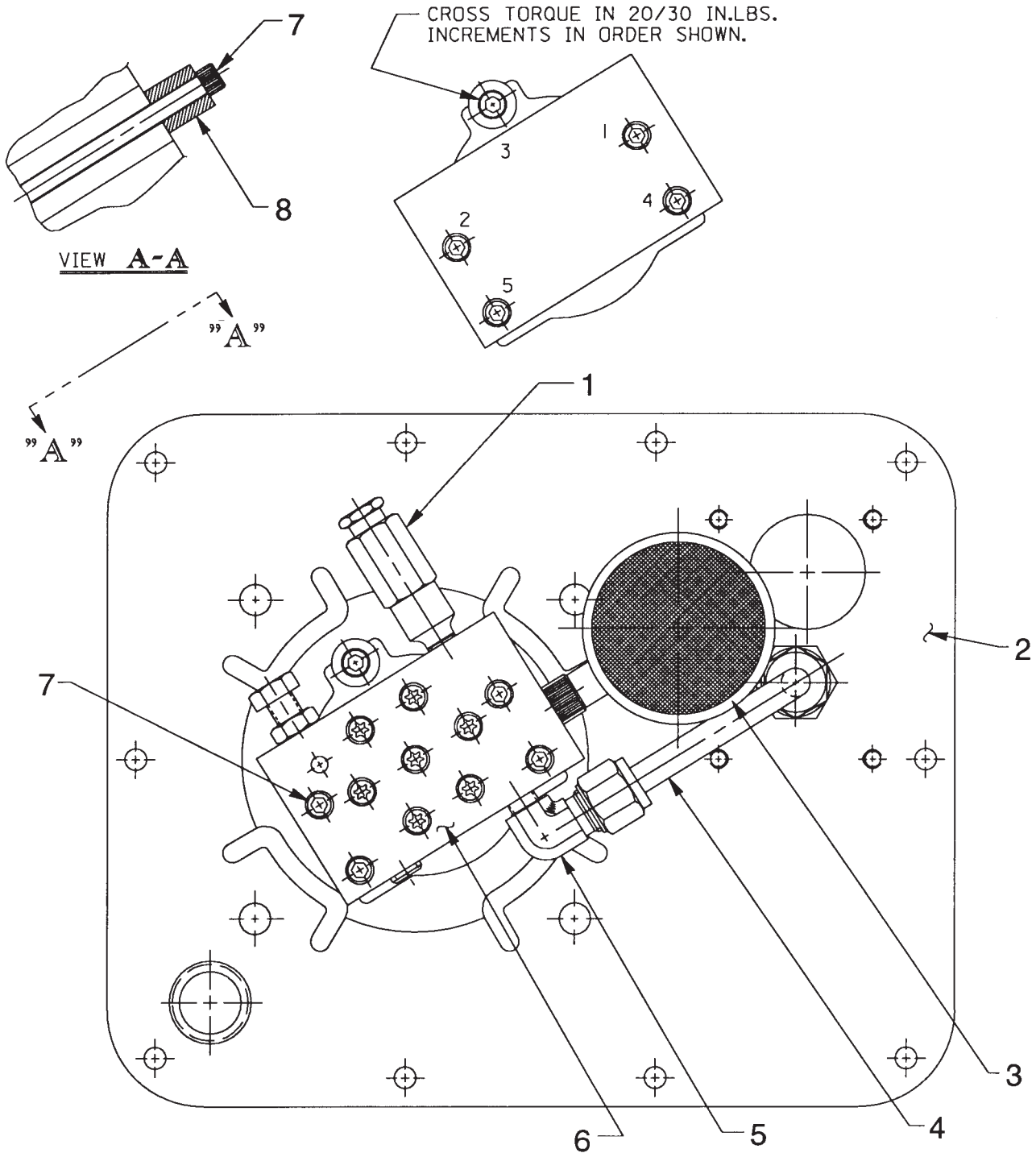

Item No.	Part No.	No. Req'd	Description
1	21278	1	Relief Valve (Set at 10,100/10,700 PSI; For PA462 and PA464)
	21278-48	1	Relief Valve (Set at 4,900-5,300 PSI; For PA464-5R)
2	61566BK2	1	Reservoir Cover
3	29682	1	Filter Strainer
4	307459	1	Oil Line Tube

Item No.	Part No.	No. Req'd	Description
5	10475	1	90° Connector
6	36922	1	High Pressure Pump Assembly (See sheet 4 of 5)
7	15642	5	Soc. Hd. Cap Screw (1/4-20 UNC x 1/2 Lg.; Torque to 55/65 in. lbs.)
8	214720	1	Spacer

HIGH PRESSURE PUMP ASSEMBLY

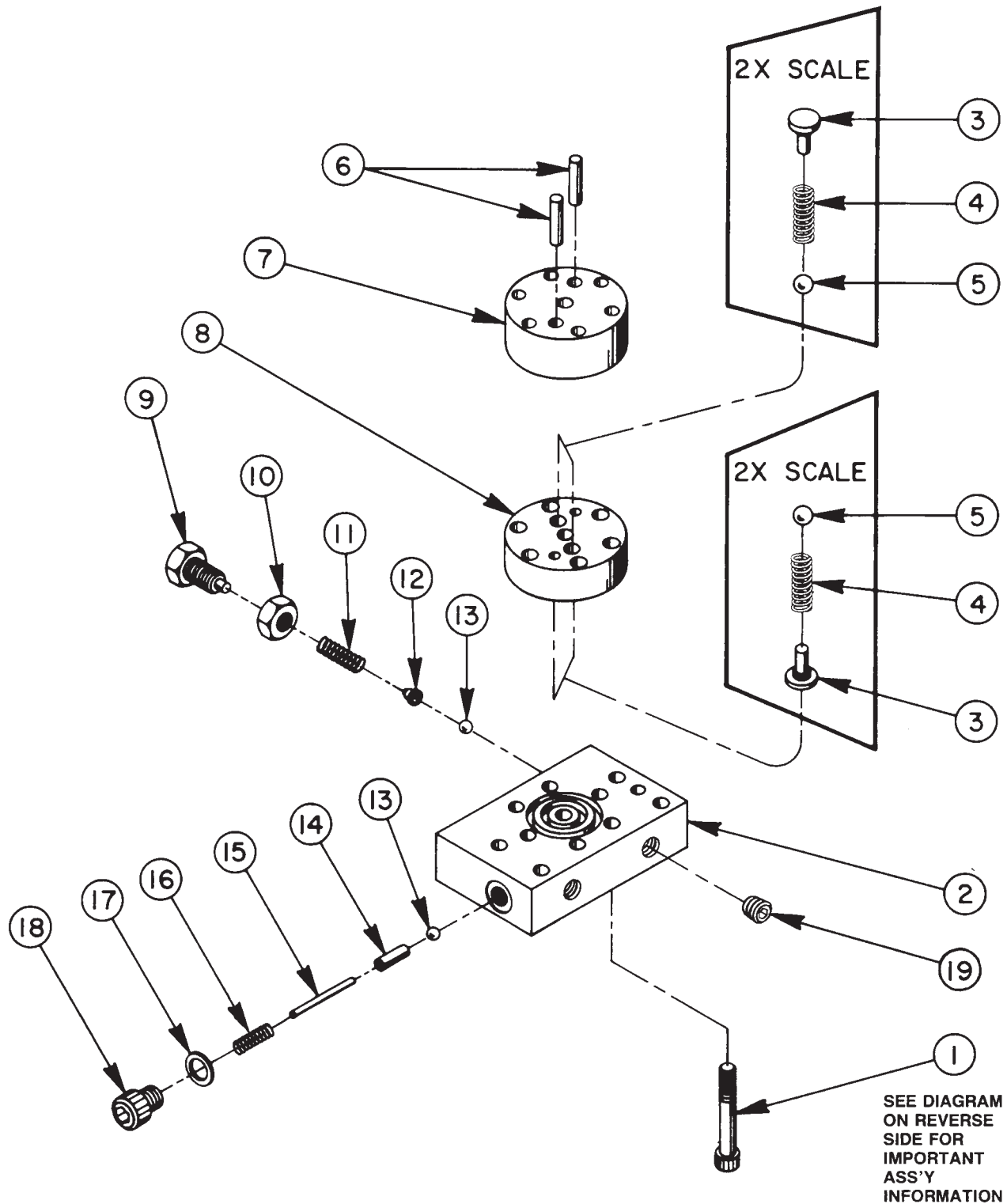

Item No.	Part No.	No. Req'd	Description
1	*16747	7	Torx Soc. Low Hd. Cap Screw (1/4-28 UNF X 1-3/4 Lg.; See diagram below)
2	*36912	1	Pump End Plate
3	*24549	4	Valve Guide
4	*10445	4	Compression Spring (5/32 O.D. X 3/4 Lg.)
5	*12223	4	Ball (3/16 Dia.)
6	*20775	2	Piston
7	*41006	1	Pump Barrel
8	*41007	1	Valve Head
9	200797	1	Adjusting Screw
10	10386	1	Hex Jam Nut (3/8-24 UNF)
11	15691	1	Compression Spring (1/4 O.D. X 5/8 Lg.)
12	200796	1	Spring & Ball Adapter
13	10375	2	Ball (1/4 Dia.)
14	201998	1	Sleeve
15	12571	1	Roll Pin (1/8 Dia. X 1-3/8 Lg.)
16	14431	1	Compression Spring (3/16 O.D. X 3/4 Lg.)
17	12042	1	Copper Washer (9/16 X 3/8 X 1/32)
18	29690	1	Cap Screw (Torque to 180 in. lbs.)
19	10427	1	Hex Female Drive Plug (1/8 NPTF)

Consult factory when replacing items marked with an asterisk (*).

BOLT TIGHTENING SEQUENCE

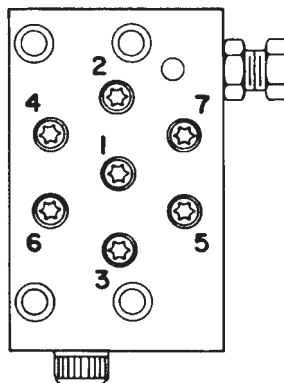

NOTE: Assemble in sequence shown. Lubricate under head and on threads. Torque to 170 in. lbs.

HYDRAULIC SCHEMATIC

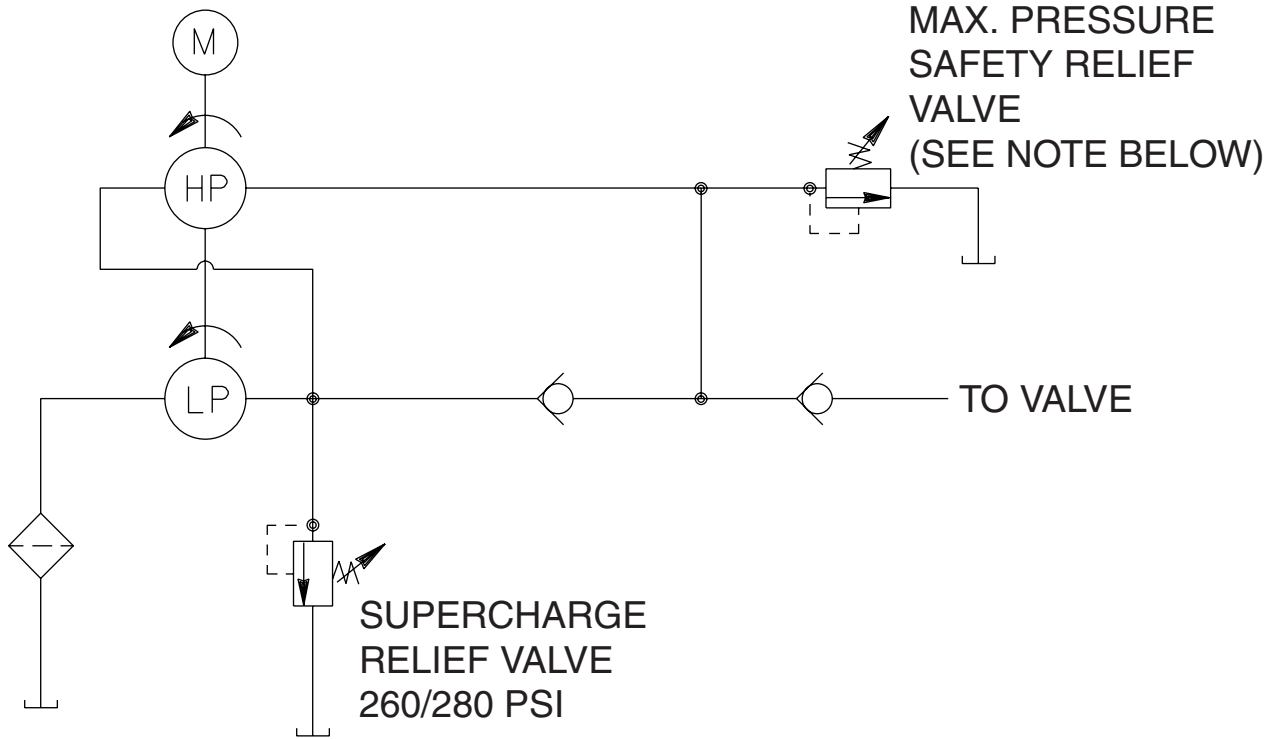

NOTE

Standard relief valves are set at 10,100/10,700 PSI.
Relief valves pre-set at special settings are available.
Refer to your pump model number or contact Power Team Technical Services.