

Parts List for:

PA55A
PA55A4
PA550
PA554

PA554-AA
PA90A
PA90A-JONES

**MODEL C
AIR HYDRAULIC PUMP**

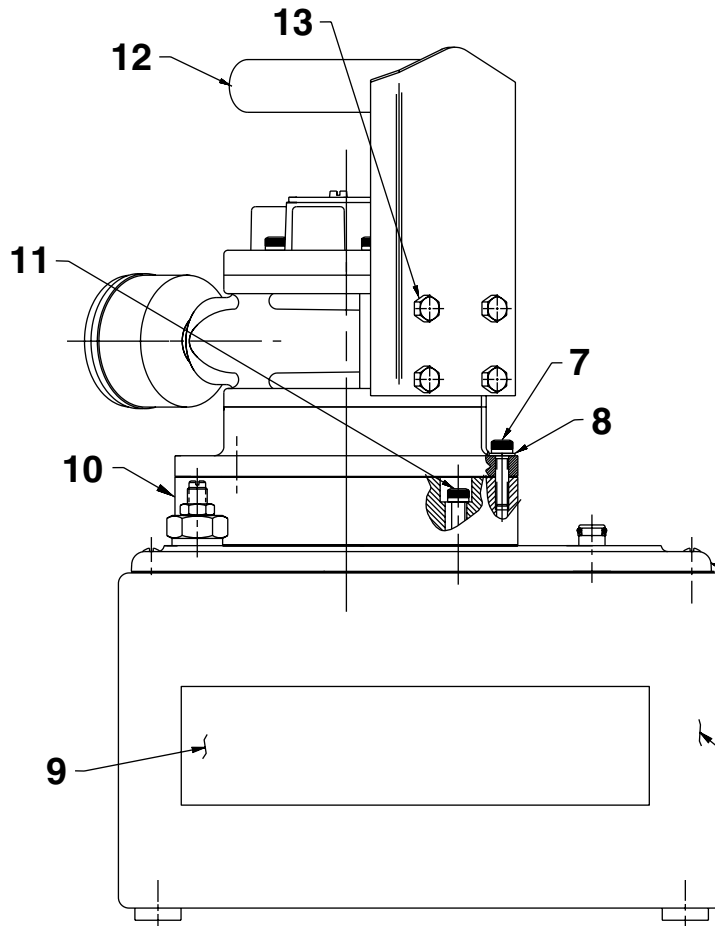
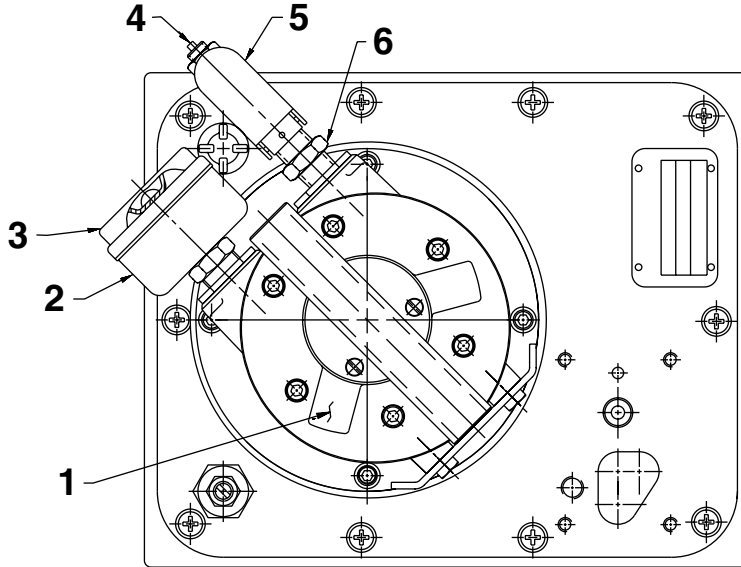

Basic Pump
Assembly
See sheet 2 of 5

Reservoir Assemblies
See sheet 5 of 5

Sheet No. 1 of 5

Rev. 2 Date: 4 June 2001

Parts List, Form No. 108174, Back sheet 1 of 5

Item No.	Part No.	No. Req'd	Description
1	66484	1	Air Motor (See Form No. 108171)
2	13966	1	Muffler
3	205505	1	Muffler Deflector
4	11127	1	Plug Fitting (3/8 NPTF)
5	13645	1	2-way Closed Air Valve
6	14056	1	Straight Fitting (3/8 NPTF)
7	10016	4	Soc. Hd. Screw (1/4-20 x 1)
8	10244	4	Lockwasher (.49 x .26)
9	309219	2	Trade Name Decal (Power Team)
10	422056	1	Motor Base
11	10022	4	Soc. Hd. Screw (1/4-20 x 1-1/2)
12	422102BK2	1	Handle Weldment
13	10005	4	Hex Hd. Cap Screw (1/4-20 x 1/2)

For PA550, PA554, PA554-AA, & PA90A-JONES



VALVE OPTIONS

9500	1	4-way Tandem Center Manual Valve (For PA554; See Form No. 100623)
66208	1	4-way Pump Mount Air Valve (For PA554A4 & PA554-AA; See Form No. 108068)

PARTS INCLUDED BUT NOT SHOWN

16797	1	90° Elbow Fitting	} For PA554-AA
9689	1	Reducer Connector	
14680	2	90° Elbow Fitting	} For PA55A4
208218	6	Straight Fitting	
421265	1	Air Operated Hand Control	
251759	1	Pump Instruction Decal	
251760	1	Release Instruction Decal	
45052	1	Three Strand 12' hose	
200609	1	Drain Tube (For PA554-AA & PA55A4)	

GENERAL PUMP ASSEMBLY

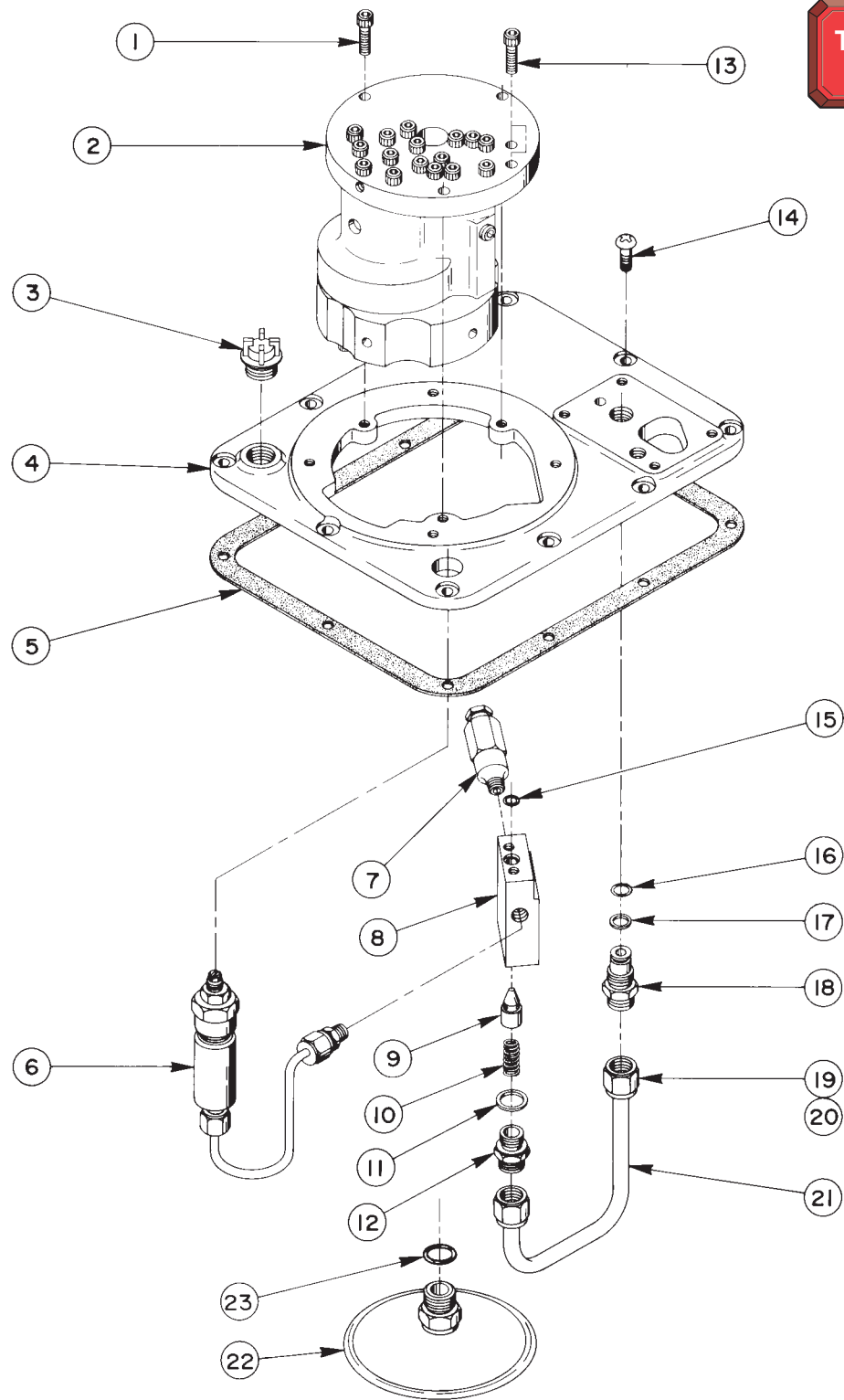

To Parts List

Parts List, Form No. 108174, Back sheet 2 of 5

Item No.	Part No.	No. Req'd	Description
1	10016	3	Soc. Hd. Cap Screw (1/4-20 UNC X 1" Lg.)
2	*27206	1	Basic Pump Ass'y Replacement (See chart below)
	*28349	1	Basic Pump Ass'y Replacement (See chart below)
3	20937	1	Filler Plug
4	40064WH2	1	Cover
5	40164	1	Gasket
6	22360	1	Pressure Regulator Ass'y (See below)
7	21278	1	Relief Valve (Set at 10,100/10,700 PSI)
	21278-50	1	Relief Valve (Set at 5,100/5,700 PSI)
	21278-15	1	Relief Valve (Set at 1,500/1,700 PSI)
8	20776	1	Valve Body
9	20771	1	Poppet
10	10425	1	Compression Spring

Item No.	Part No.	No. Req'd	Description
11	10261	1	(3/8 O.D. X 3/4 Lg.) Copper Washer (3/4 X 19/32 X 1/32)
12	20770	1	Connector (Torque to 40/45 ft. lbs.)
13	10015	2	Soc. Hd. Cap Screw (1/4-28 UNF X 1" Lg.; Torque to 180 in. lbs.)
14	10177	10	Mach. Screw (1/4-20 UNC X 3/4 Lg.)
15	10266	1	O-ring (3/8 X 1/4 X 1/16)
16	10268	1	O-ring (1/2 X 3/8 X 1/16)
17	11863	1	Teflon Backup Washer (1/2 X 3/8 X 1/16)
18	20787	1	Valve Connector
19	10430	2	Tube Sleeve
20	10431	2	Tube Nut
21	21045	1	Oil Line
22	21345	1	Filter Ass'y (Includes Item 23)
23	10527	1	O-ring (13/16 X .644 X .087)



*Includes all items on sheet 3 of 5 and items 1, 7, 8, 9, 10, 11, 12, 13, 15 & 22 on this sheet.

BASIC PUMP REPLACEMENT CHART Low Speed (3,450 RPM)

SERIES	MAX. PSI	BASIC PUMP & COVER PLATE ASS'Y	BASIC PUMP REPLACEMENT	HIGH PRESSURE PUMP ASS'Y USED	NO. OF PISTONS
PA55A, PA554-AA, PA550, PA554, PA55A4	10,000	50404	27206*	33113	3
PA90A	5,000	50406	28349*	33114	6
PA90A-JONES	1,500	50406-15	-	33114	6

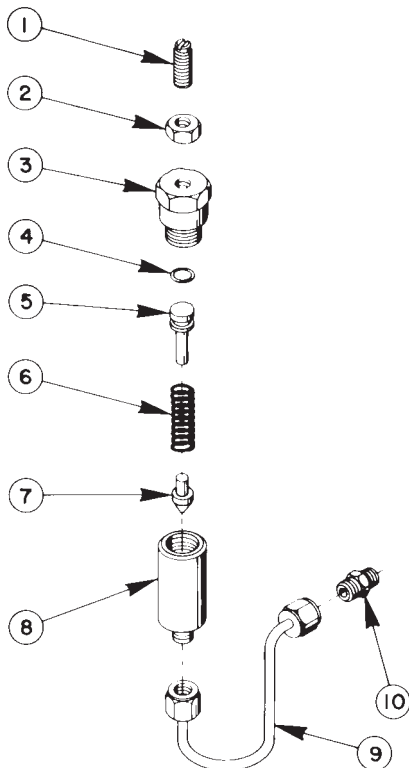

PRESSURE REGULATOR ASSEMBLY

Item No.	Part No.	No. Req'd	Description
1	22362	1	Adjusting Screw
2	10386	1	Hex Jam Nut (3/8-24 UNF)
3	21305	1	Valve Cap
4	10268	1	O-ring (1/2 X 3/8 X 1/16)
5	21306	1	Spring Guide
6	10495	1	Compression Spring
7	21046	1	Valve Stem
8	22361	1	Body
9	29267	1	Oil Line Ass'y (With nuts)
10	14844	1	Connector Fitting

BASIC PUMP ASSEMBLY

To Parts List

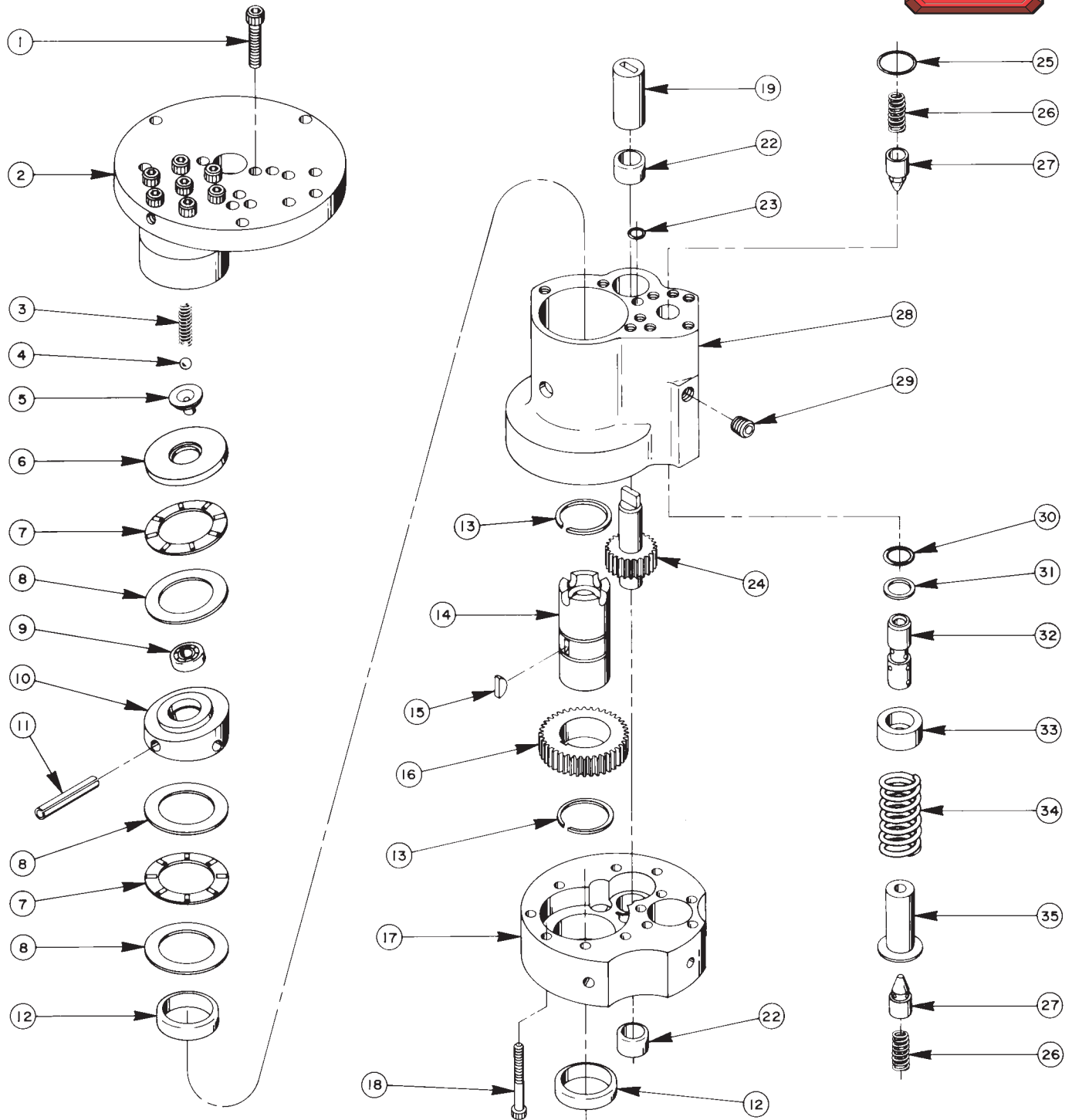

Parts List, Form No. 108174, Back sheet 3 of 5

Item No.	Part No.	No. Req'd	Description
1	10020	9	Soc. Hd. Cap Screw (1/4-20 UNC X 1-1/4" Lg.; Torque to 170-180 in. lbs.)
2	33113	1	High Pressure Pump Ass'y (See sheet 4 of 5 & chart on back of sheet 2 of 5)
	33114	1	High Pressure Pump Ass'y (See sheet 4 of 5 & chart on back of sheet 2 of 5)
3	10361	1	Compression Spring (1/4 O.D. X 1" Lg.)
4	10375	1	Steel Ball (1/4" Dia.)
5	23547	1	Bearing Top Plate
6	23548	1	Top Plate
7	11228	2	Thrust Bearing
8	11813	3	Bearing Race
9	11814	1	Ball Bearing
10	23549	1	Angle Plate
11	11955	1	Roll Pin
12	11064	2	Needle Bearing
13	11261	2	Retaining Ring
14	23556	1	Shaft
15	11821	1	Woodruff Key
16	23557	1	Gear
17	30533	1	Pump End Plate
18	10001	12	Soc. Hd. Cap Screw (#10-32 UNF X 1-3/4 Lg.; Torque to 50 in. lbs.)
19	252108	1	Coupling
22	11199	2	Needle Thrust Bearing (See note below)
23	10266	1	O-ring (3/8 X 1/4 X 1/16)
24	21272	1	Drive Gear
25	10303	1	O-ring (7/8 X 3/4 X 1/16)
26	10425	2	Compression Spring (3/8 O.D. X 3/4 Lg.)
27	20771	2	Poppet
28	40120	1	Pump Body
29	10427	1	Pipe Plug (1/8" NPTF)
30	10271	1	O-ring (11/16 X 1/2 X 3/32)
31	12389	1	Teflon Backup Washer (11/16 X 1/2 X 1/16)
32	20849	1	Spool
33	23255	1	Spring Guide
34	10426	1	Compression Spring (1" O.D. X 1-13/16 Lg.)
35	23256	1	Spring Guide



NEEDLE BEARING INSTALLATION SPECIFICATIONS

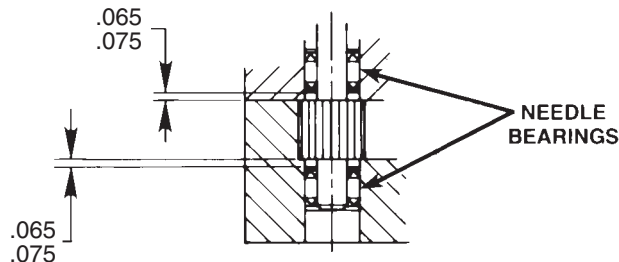

When replacing the needle bearings on the drive gear of the basic pump, the dimensions shown must be as specified.

Note: Shaded areas reflect last revision(s) made to this form.

HIGH PRESSURE PUMP ASSEMBLY

To Parts List

SEE DIAGRAM ON REVERSE SIDE FOR IMPORTANT ASS'Y. INFORMATION

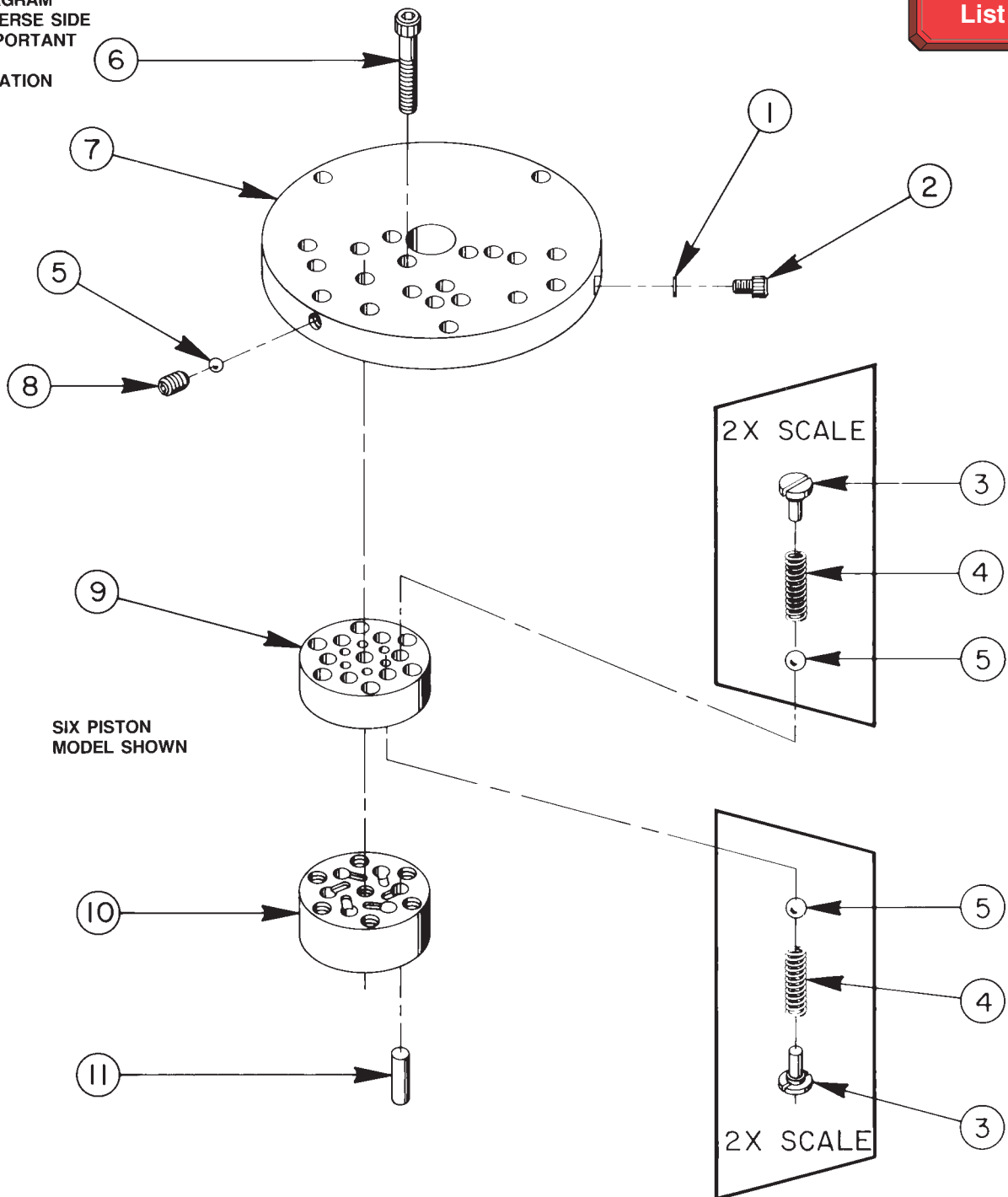

33113 PUMP ASSEMBLY
3 Pistons - 9/32 Dia.

Item No.	Part No.	No. Req'd	Description
1	10442	1	Copper Washer (3/8 X 1/4 X 1/32)
2	10002	1	Soc. Hd. Cap Screw (1/4-20 UNC X 3/8" Lg.; Torque to 140/160 in. lbs.)
3	24549	6	Valve Guide
4	10445	6	Compression Spring (5/32" O.D. X 3/4" Lg.)
5	12223	7	Steel Ball (3/16" Dia.)
6	10023	7	Soc. Hd. Cap Screw (1/4-28 UNF X 1-1/2 Lg.; Torque to 170/180 in. lbs.; See note below)
7	50411	1	Top Plate
8	10519	1	Soc. Set Screw (1/4-20 UNC X 3/8 Lg.; Torque to 65/70 in. lbs.)
9	40630	1	Valve Head
10	41062	1	Pump Barrel
11	21628	3	Piston

33114 PUMP ASSEMBLY
6 Pistons - 9/32 Dia.

Item No.	Part No.	No. Req'd	Description
1	10442	1	Copper Washer (3/8 X 1/4 X 1/32)
2	10002	1	Soc. Hd. Cap Screw (1/4-20 UNC X 3/8" Lg.; Torque to 140/160 in. lbs.)
3	24549	12	Valve Guide
4	10445	12	Compression Spring (5/32" O.D. X 3/4" Lg.)
5	12223	13	Steel Ball (3/16" Dia.)
6	10023	7	Soc. Hd. Cap Screw (1/4-28 UNF X 1-1/2 Lg.; Torque to 170/180 in. lbs.; See note below)
7	50411	1	Top Plate
8	10519	1	Soc. Set Screw (1/4-20 UNC X 3/8 Lg.; Torque to 65/70 in. lbs.)
9	41048	1	Valve Head
10	41063	1	Pump Barrel
11	21628	6	Piston

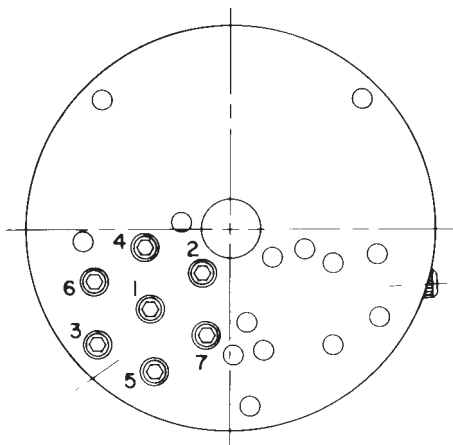

BOLT TIGHTENING SEQUENCE

NOTE: Assemble in sequence shown.
 Lubricate under head and on threads.
 Torque to 180 in. lbs.

RESERVOIR ASSEMBLIES

2 GAL. RESERVOIR

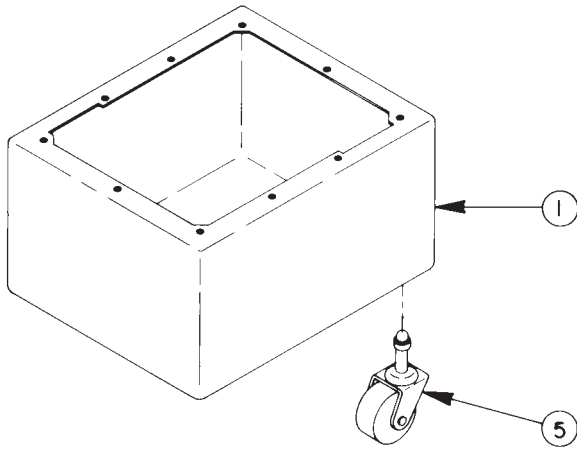

5 & 10 GAL. RESERVOIRS

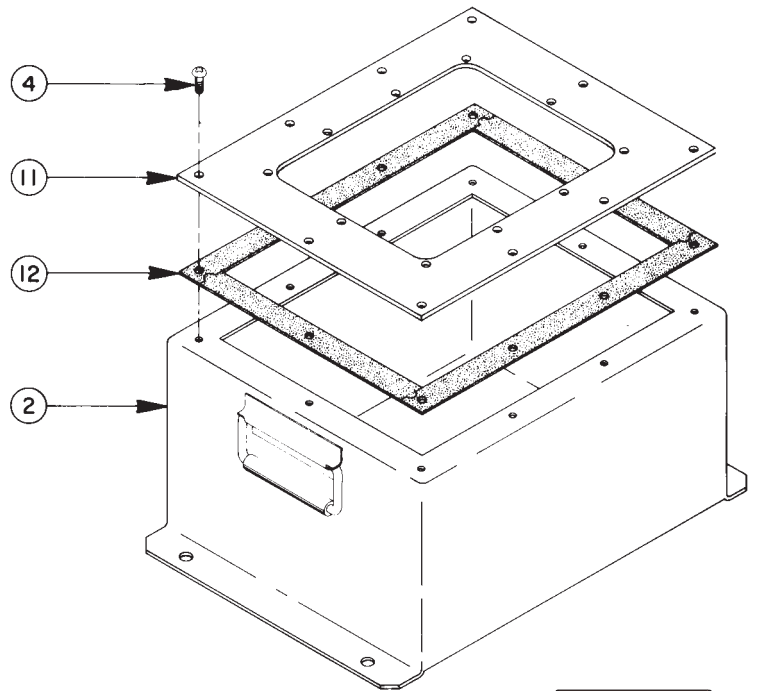

FILTER & EXTENSIONS

Used on 5, 7 & 10 Gal. Reservoirs as Applicable

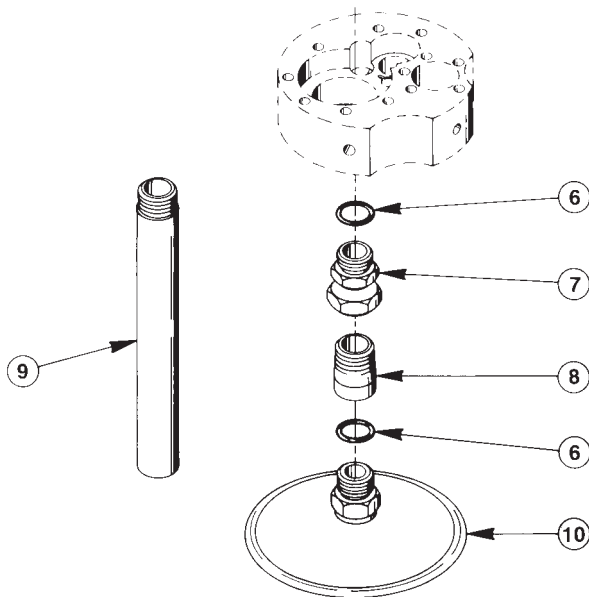

7 GAL. RESERVOIR

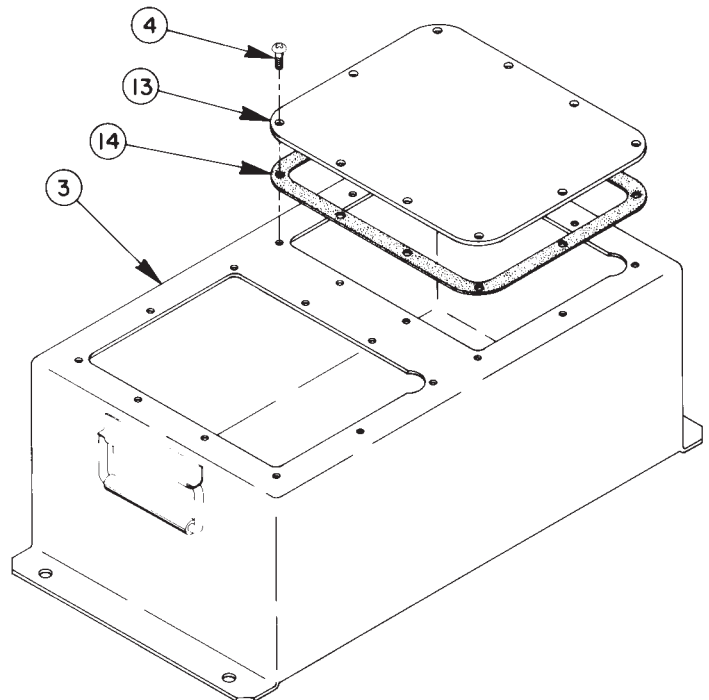

Parts List, Form No. 108174, Back sheet 5 of 5

NOTE: For complete Reservoir Assembly order the following:

23509	---	OTC complete 5 Gal. Reservoir Assembly
23510	---	OTC complete 7 Gal. Reservoir Assembly
23511	---	OTC complete 10 Gal. Reservoir Assembly
RP50	---	Power Team complete 5 Gal. Reservoir Assembly
209124	---	Power Team complete 7 Gal. Reservoir Assembly
RP100	---	Power Team complete 10 Gal. Reservoir Assembly

These numbers include the following parts listed below as applicable.

Item No.	Part No.	No. Req'd	Description
1	40063BL2	1	2 Gal. Reservoir (OTC)
	40063OR9	1	2 Gal. Reservoir (Power Team)
	60597OR9	1	2 Gal. Reservoir with handles & drain (Power Team)
	420080	1	Reservoir (For PE90C-EPR)
	40063GY8	1	2 Ga. Reservoir (For PA90A-JONES)
2	40137BL2	1	5 Gal. Reservoir (OTC)
	40137OR9	1	5 Gal. Reservoir (Power Team)
	40193BL2	1	10 Gal. Reservoir (OTC)
	40193OR9	1	10 Gal. Reservoir (Power Team)
3	50051BL2	1	7 Gal. Reservoir (OTC)
	50051OR9	1	7 Gal. Reservoir (Power Team)
4	10177	10	Mach. Screw (1/4-20 UNC X 3/4 Lg.)
5	10494	4	Swivel Caster (For 2 Gal. Res.)
6	10527	2	O-ring (13/16 X .644 X .087)
7	10528	1	Adapter Union
8	22033	1	Suction Line (For 5 & 7 Gal. Res.)
9	22037	1	Suction Line (For 10 Gal. Res.)
10	21345	1	Filter Assembly
11	40194AL2	1	Adapter Cover Plate (For 5 & 10 Gal. Res.)
12	40490	1	Gasket (For 5 & 10 Gal. Res.)
13	41088AL2	1	Cover Plate (For 7 Gal. Res.)
14	40164	1	Gasket (For 7 Gal. Res.)



PARTS NOT SHOWN

11023	2	Trade Name Decal (OTC)
309219	2	Trade Name Decal (Power Team)

Refer to any operating instructions included with this product for detailed information about operation, testing, disassembly, reassembly, and preventive maintenance.

Items found in this parts list have been carefully tested and selected. **Therefore: Use only genuine replacement parts!**

Additional questions can be directed to our Technical Services Department.