

RAIL OPERATING EQUIPMENT

*Your choice for Safe, Reliable and High-Performance
Point Operation*

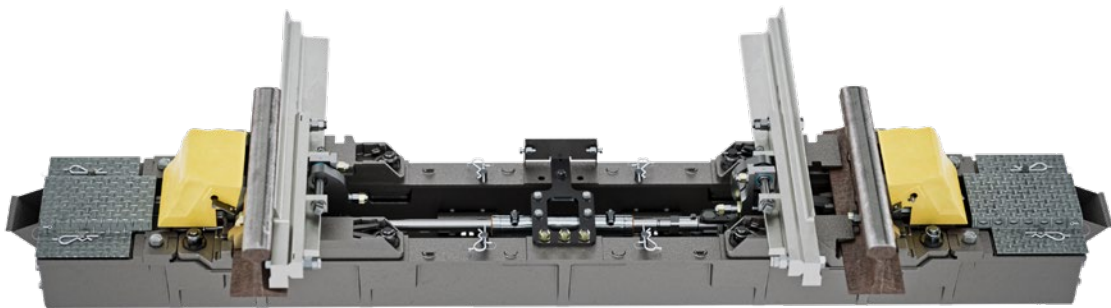

CLAMP LOCK

WHAT IS A CLAMPLOCK?

Clamplock point machines are a signaling system used to drive, lock and detect switch rails on turnouts/switches & crossings.

As a hydraulically actuated system the rams drive the switch rails and the Clamplock mechanism. This system provides both reliable mechanical and hydraulic locking of the switch rail. At every stage of switch throw from open to closed, the onboard detectors will reliably output an open or closed position which can be wired into the customers signalling systems.

As the Clamplock system is a modular design it can be adapted to suit majority of rail types (except tram), gauge, inclination, back drive type, insulated/non-insulated, single-double slips, diamonds etc.

CLAMPLOCK HISTORY

Originally designed in the UK by British Rail, the Clamplock point machine was first introduced in the late 1960s as the MK1 Clamplock.

In 1987 British Rail improved on the original design which extended the maintainability, reliability and overall performance releasing the new design as MK2 Rail Clamplock (RCPL).

The core difference between the MK1 and MK2 was the change from a fabricated lock body to a cast lock body. MK2's are also referred as "cast body" mechanism. This design represents the current Clamplock points machine with the old MK1 becoming obsolete.

The Clamplock point machine is designed to be a modular solution based around a singular lock and detection system that via the adaptation of various ancillary parts can be adjusted to suit all rail profiles (excluding trams), the first MK2 was initially intended for 113lb Flat Bottom Vertical (FBV) stock rail and 113lb full depth switch rail. However, since 1987 the Clamplock points machine has been used on numerous other rail profiles around the world as well as modern shallow depth switch rails including but not limited to CEN60, UIC54/CEN56, AS60 rail profiles.

In 1994 British Rail was privatized forming Railtrack, later called Network rail. During privatisation, design and manufacture of Clamplock was transferred to Smiths Hydraulic Industries Company which in 2001, was purchased by SPX fluid power and later rebranded to Hydraulic Technologies Rail Systems.

In 2009 SPX FLOW (now Hydraulic Technologies) Rail Systems, introduced the In-bearer Clamplock (IBCL) for MK2's. The introduction of IBCL meant the Clamplock mechanism could be housed within a Hollow Steel Sleeper which proved to be a widely preferred and adopted arrangement over the exposed in-between bearer arrangement known as RCPL. IBCL's also allowed the introduction of a high-flow powerpack system for use with high-speed applications and a hydraulic back drives.

In 2020 SPX FLOW (now Hydraulic Technologies) Rail Systems launched the MK3, a heavily improved version of the Clamplock Points machine.

Taking in customer feedback, and market needs with a focus on reliability and sustainability the MK3 was able to capture and implement these improvements through new materials, designing out failures and potential failure modes, reducing componentry and time to maintain and install as well as significant improvements to mean time between service and failures.



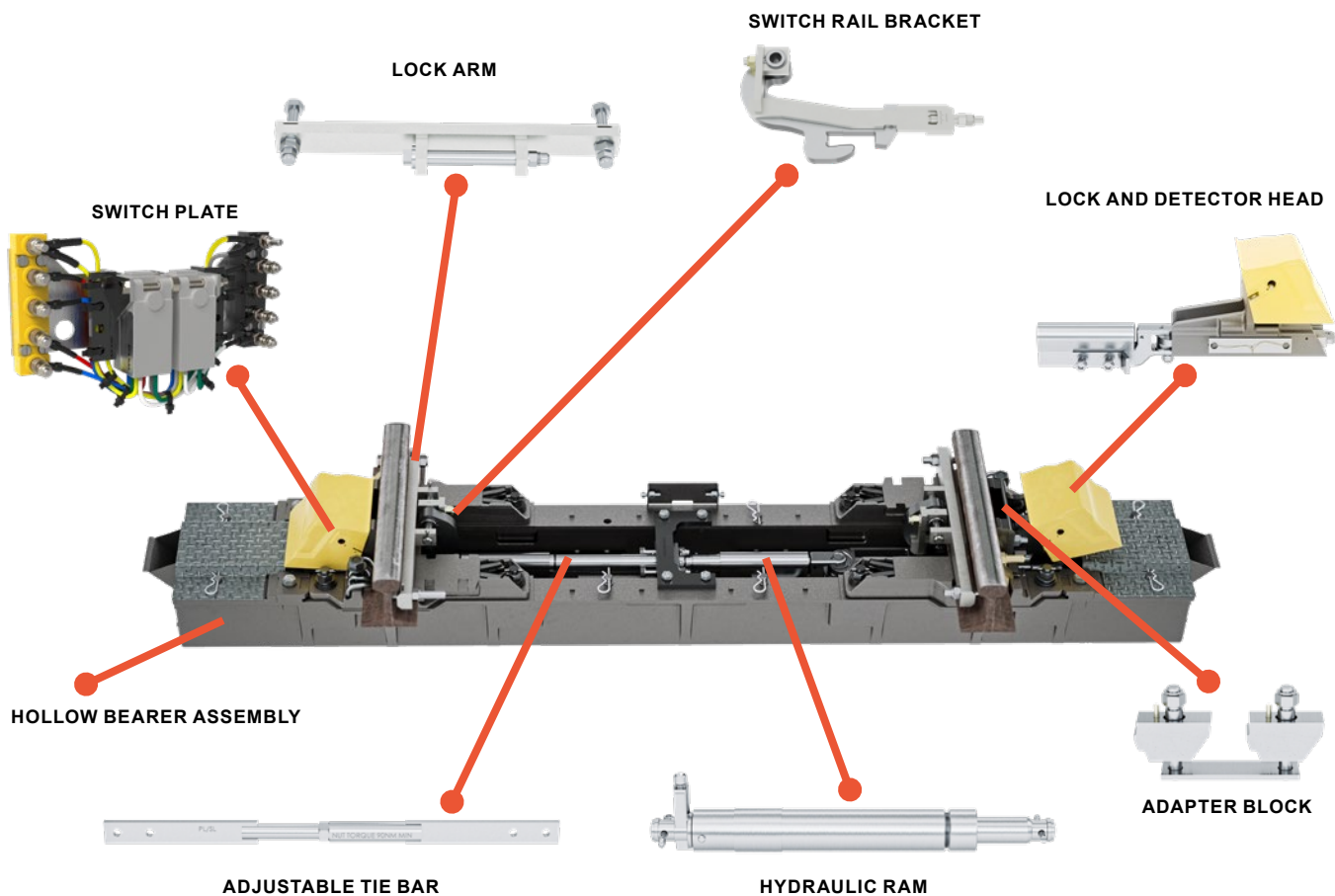

Clamp lock key features

Detection Assembly

Switch plate assembly directly installed to the detector head assembly, on each side of the stock rail, providing detection of both the open and closed switches

Hollow Bearer Assembly

Solid steel cast bearer, for use with IBCL systems, this assembly secured the the mechanism direct to the rails, enabling the ballast to be tamped, preventing excess vibration.

Adjustable Tie Bar Assembly

Provide the mechanical link between both left and right hand switch rails, additional to the stretcher bar assembly Available for use across various track gauges

Adaptor Block Assembly

Secures the detector head assembly to the stock rail, the design is adjustable to fit all rail profiles.

Lockarm and Switch Rail Bracket

Each assembly is designed to fit with the switch a specific rail profile and provide a mechanical lock of the switch rail to the stock rail. By providing a mechanical lock of switch rail, in the unlikely event that the hydraulics where lost/ removed, the switch would remain closed and locked, preventing a train derailment, and would requiring a hydraulic activation to release.

Hydraulic Ram

Single acting ram which can be adjusted to fit various gauges and permanent way movements and conditions.

Lock and Detector Head Assembly

Cast detector head assembly which provides the adjustable mechanical lock of the lock arm from the switch rail.

This also houses the detector blade and associated cams which are used to activate the detection switch assembly, providing a logic based signal for switch rail positions.

MK3 ADVANCEMENTS

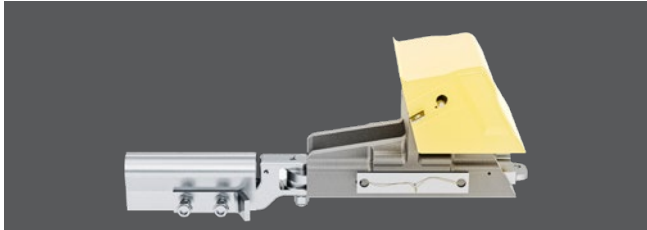

Detector Cam Upgrades

Geometry changes to reduce sharp edges.
 Addition of vibration protection – restraint of adjustable cam by introducing key & keyway to the design.
 New surface finished method was introduced to improve hardness for the contact surface.

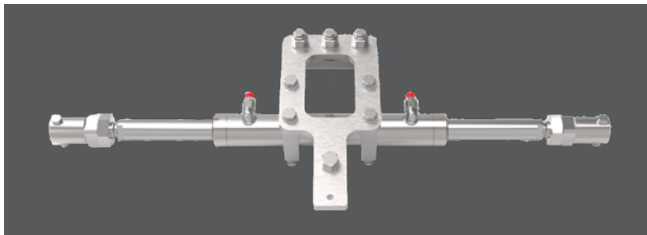

Double Acting Hydraulic Cylinder

No adjustable Tie-Bar, No Centre Thrust Packing.
 Rod end adjuster replaces centre thrust bracket packing process.



Switch Rail Bracket Assy

An A9 pin was introduced to the system which eliminates the split pin from the design.



Detector Blade and Drive slide

Detector blade geometry was redesign to accommodate vertical movement of the switch rail to prevent vibration of the adjustable cam.
 Drive slide geometry change to include a key way to reduce vibration and extended length to provide support for the adjustable cam.

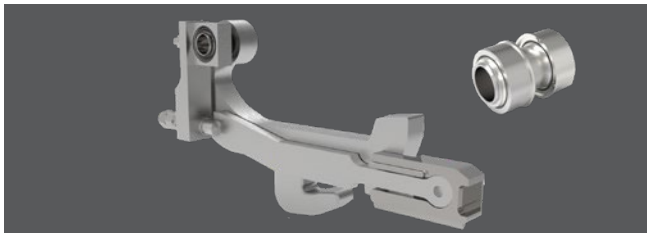

Lock Arm assy

Spherical bearing to provide additional flexibility to lock arm angles (negates pin loading on lock arm).
 A new design of the adjustable cam to reduce wear and compensate for switch rail movement during operation.

CLAMP LOCK POWER PACK

Compact, Robust and Reliable

This Hydraulic power pack unit, supply's pressurised oil via two or four hoses to the single or double acting rams of the Clamplock mechanism.

Standard

- External power pack can be placed in a location a safe distance from the Clamplock mechanism.
- Extended bearers are not required.
- Electrical supply can be either DC or AC. (110vdc standard)
- In-built relief valves prevent damage to the assembly during a run through.
- Manual override function, allows the Clamplock to be easily operated manually, when required.
- Remote condition monitoring capability available.
- Brushed and brushless motor options are available (Approval Specific)
- Can be supplied with an in-built plug coupler to enable quick install requirements.
- Fully Serviceable.

High Flow Power Packs

- 110vdc DC driven
- Designed for use on High-Speed line turnout applications.
- Provides hydraulic back drive ability with increase oil flow.



CUSTOMER SERVICE CENTERS

Dagenham, United Kingdom
Unit 7, Thames Gateway Park
Choats Road,
Dagenham, Essex RM9 6RH
United Kingdom
Tel: +44 (0) 208 526 7100
FP.UK.Rail.Systems@spxflow.com

Hydraulic Technologies reserves the right to incorporate our latest design and material changes without notice or obligation. Design features, materials of construction and dimensional data, as described in this bulletin, are provided for your information only and should not be relied upon unless confirmed in writing. Please contact your local sales representative for product availability in your region. For more information,